

1100 / 1100-S STATIC ELIMINATORS

The 1100 and 1100-S Static Eliminators are high performance ionisers for modern manufacturing. A resistive coupling between the high voltage source and the emitters gives them powerful ionisation with completely shockproof operation.

Their compact size makes them particularly suited to web and sheet applications where space is limited.

PERFORMANCE

- 5.5 - 6 kV of ionising power.
- Resistively coupled emitters for maximum ionisation efficiency.

ESSENTIAL QUALITIES

- Most compact resistively coupled static eliminator bar available.
- All live parts are epoxy encapsulated for protection, reliability and a long life.
- Shockproof operation.
- Long-life emitters.

CONNECTIVITY AND CONTROL

- Wide choice of Fraser power units, including remote monitoring of operational status.

APPLICATIONS

- Position 20 - 100 mm from material. Best performance within 50 mm.
- Simple to install and maintain.
- Suitable for most industrial processes. Certified cleanroom compatible to ISO Class 4.



SPECIFICATION

Construction:

Anodised aluminium, epoxy resin, ABS and hardened emitters.

Cable:

Hi-Flex 30 kV screened cable with 70 mm bend diameter. Standard length is 2 m - longer lengths can be specified at time of order (subject to maximum load on power unit).

Safety:

5 mA maximum current from power unit. High voltage resistance inside bars further limits current below 50 µA.

Power Unit:

Use with Fraser 5.5 kV and 6 kV Power Units. See Datasheets.

Environmental:

60 °C maximum temperature. 70 % rH non-condensing max. IP66. Fully sealed.

Certification:

CE.

Options:

Available in 2 versions:
 1100 with fixed mounting studs.
 1100-S with adjustable mounting studs.

HOW IT WORKS

High voltage is applied in a controlled and safe way to the emitters. This ionises the surrounding air and releases ions of the opposing polarity needed to neutralise the charge.

Unused ions quickly dissipate into the atmosphere.

DIMENSIONS AND CONSTRUCTION

Available lengths: from 60 mm to 3000 mm.

1100

Most compact version with fixed mounting studs 20 mm from each end. Studs are M4 x 20 mm.

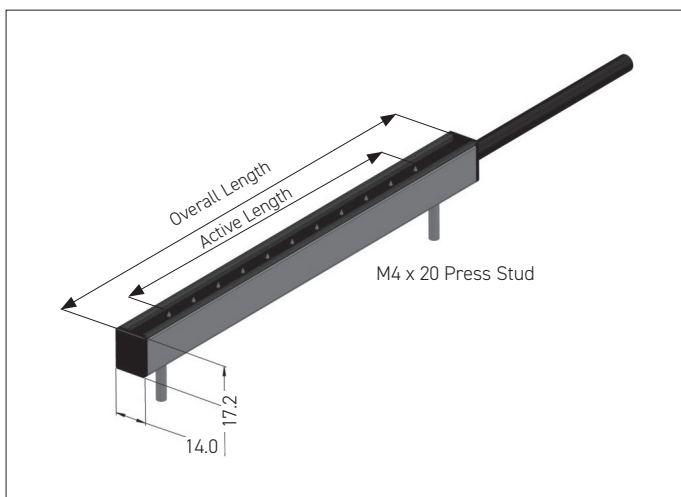

1100-S

Version with versatile mounting - with a slot in which M4 mounting studs can slide.

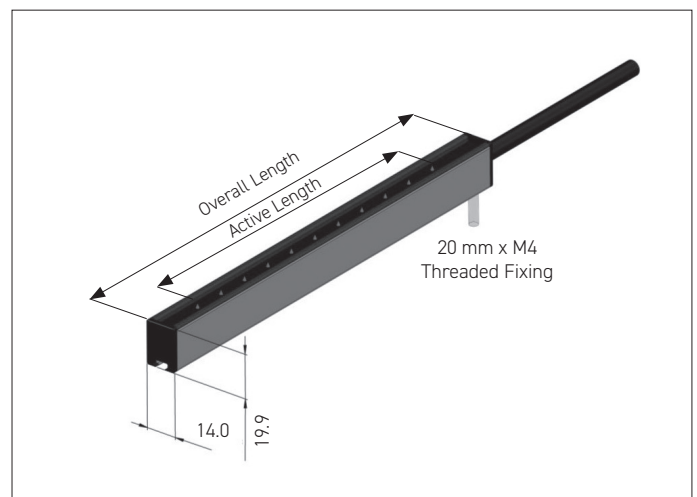

Active ionisation length = overall length - 20mm.

