

HP50-ION POWER UNIT

The HP50-ION is part of a comprehensive family of advanced power units from Fraser, which provides high voltage to produce ionisation in Fraser's range of AC static eliminators. There is a model for every customer requirement.

The HP50-ION offers the added benefit of an Ionis performance monitoring system which gives the user live information on the status and efficiency of the system.

PERFORMANCE

- 6 kV of ionising power.

ESSENTIAL QUALITIES

- Unique level of local and remote operational feedback.
- Exceeds international safety requirements, with automatic shut-down if there is a short on the static eliminator.
- Low running cost, typically 30 Watts.

CONNECTIVITY AND CONTROL

- The LED display on the power unit shows:
 - Condition of bars and whether they need cleaning
 - Charge level in material
 - Power ON and high voltage OK
 - Alarm if there is a fault.
- Remote monitoring option provides 24 V signal for each of the above.

APPLICATIONS

- The HP50-ION is for static eliminator applications where the operator requires operational feedback and control.
- HP50-ION (Model 3111) may be used to power Fraser EX-1250 Static Eliminators.



SPECIFICATION

Construction:

Powder coated steel case. Transformer with fully encapsulated windings.

Electrical Output:

6 kV with maximum peak voltage of 7.75 kV. Secondary current limited to 5 mA.

Maximum Load:

30 m of combined Bar and HT Cable.

Safety:

The design is current-limited to 5 mA. If more than 5 mA current is drawn the transformer is designed to shut down. Power will restart when the excessive load or fault is removed.

Electrical Input:

115 V or 230 V, 50 or 60 Hz. Please specify frequency (Hz) as well as input voltage. 3 m mains cable is supplied (longer can be specified).

Environmental:

50 °C maximum temperature. 70 % rH non-condensing max. Location should be dry and oil-free. IP54.

Certification:

CE, CB and UL.

Options:

Remote monitoring to show status of high voltage and Bars/Electrodes.

CONTROL PANEL

1. Display of charge in material.
2. 5 level display of contamination/dirt on bar:
Green = clean Yellow = average dirt Red = clean urgently
3. Alarm: Show red if fault.
4. Power: ON Indicator.
5. HV OK: Monitors HV output.
6. Calibration button.

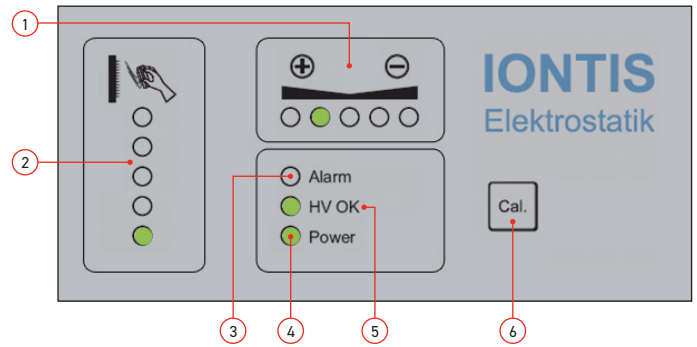

DIMENSIONS

