

Model 101 and 201 Static Dischargers

Fraser static dischargers are very powerful static eliminators. Being highly efficient, cost effective and easy to install, they are chosen by thousands of companies in industry to neutralise static on sheets and webs.



Model 101



Model 201

How it Works

The “brushes” have a large number of highly conductive fibres. The fine tips of the fibres concentrate the electric field of the static charge and ionise the air.

This ionised air provides ions of the opposite polarity to neutralise the static charge and allow it to flow to earth through the brush body.

The tips of the fibre do not need to touch the material to be neutralised, normally they are positioned 2-3mm from it. If they are allowed to touch the material, there could be an improvement in performance because there may be some conduction in addition to the ionisation, however they may be some trade-off in that the brushes could wear or contaminate more quickly.

The Static Discharger body must be connected to an earth/ ground.

They are available in two body styles, models 101 and 201 and a choice of fibres and fibre lengths.

Which Model Brush to use?

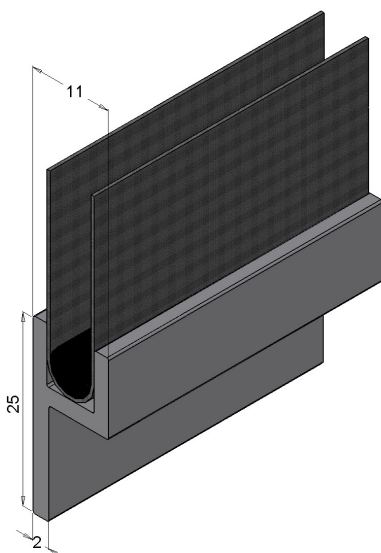

Model 101

Model 101 is the most popular style for general industrial use. The 2mm extruded aluminium walls give it physical strength and rigidity. It is available in any length up to 4m. For ease of installation, the 101 can be drilled along the single wall upright of the “h” body.

Notes

Model 201

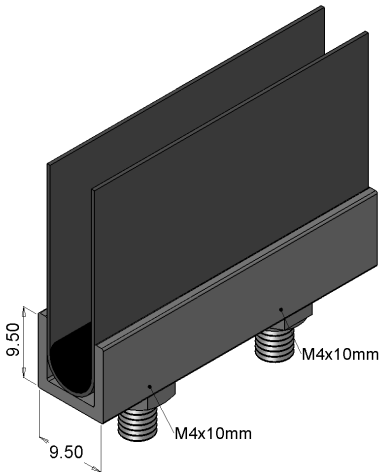

Model 201 has a 9.5mm x 9.5mm square body with M4 fixing studs 10mm from each end and in the middle for lengths above 1m. The 201 is not as rigid as the 101, and is available up to lengths of 3m.

Notes

Which Fibre to use

There is a choice of carbon or conductive **nylon** fibre. Both are soft and non abrasive. The standard fibre length is 18mm. Optional lengths are 30mm, 50mm and 80mm.

Carbon Fibre:

This is the most popular fibre, providing the best neutralisation at the lowest price. The carbon fibre has a density of 60,000 x 6/7 μ filaments per cm.

Nylon:

Conductive **nylon is** a new fibre which is soft and resilient. It is not as powerful as the carbon fibre, but has the advantage that it is washable. The **nylon** has a density of 10,000 x 15 μ filaments per cm.

Applications

Fraser Static Dischargers are low cost solutions used where the extra cost of electrical static eliminators cannot be justified, they are used on wrapping machines, gravure and flexo printing machines, coaters, laminators, labelling and coding machines, ink jet printers, print finishing, digital printing, sleeving machines, charge application systems - and countless other processes.

We do not recommend these products for use in food or pharmaceutical applications if there is a risk of broken fibres falling into the product.

Hazardous Areas

See EX-HPSD for use in hazardous areas such as coating, laminating and gravure printing.