

# 3014 COMPACT 24 V DC STATIC ELIMINATOR BAR

## DISTRIBUTOR MANUAL



### Contents

### Page

1. Background	02
2. Summary of New Features and Sales Points	03
3. Technical Specification	04
4. Market and Applications	06
5. Performance and Competition	08
6. Installation: Mechanical and Environmental	09
7. Installation Electrical	12
8. Operation, Maintenance and Safety	19
9. Troubleshooting	21
10. Accessories, Spare Parts	22

3014-DM-Iss.2

---

## 1. BACKGROUND

---

Developed as a direct response to the needs of major OEMs for a compact 24 V DC Bar to replace conventional AC static eliminators with external power units and high voltage cables, the 3014 was launched in November 2016.

The 3014 was designed to give customers what they had requested as well as build upon the success of our 3024 Bar which had become the most successful product in the Fraser static eliminator range.

The 3024 Bar was launched in 2011 and became a very important product for us. It gave our customers the benefits of:

- High Performance
- No HT Cables
- 24 V DC Supply
- Compact size with active length same as overall length
- Remote and on-Bar monitoring
- Long-life Tungsten emitters

The 3014 has all the benefits of the 3024 but also offers:

- Compact dimensions designed to match the size of our AC 1250-S Bar.
- “Clean Me” remote monitoring, to signal to customers that maintenance is needed.
- Lower cost – the 3014 is on average 25% cheaper than the 3024 – making it the most competitively priced 24 V DC Bar on the market.

The 3014 is a short range static eliminator operating at 7.5 kV DC using pulsed DC, with field overlap to enhance performance.

Please read the following notes which explain how the 3014 Bar works and how your customers can benefit from our 24 V DC Technology.

3014-DM-Iss.2



Scotts Business Park, Bampton, Devon, GB, EX16 9DN  
T + 44 (0) 1398 331114 F + 44 (0) 1398 331411  
E sales@fraser-antistatic.co.uk W www.fraser-antistatic.com  
© Fraser Anti-Static Techniques Ltd 2019



---

## 2. SUMMARY OF KEY FEATURES AND SALES POINTS

---

### COMPACT SIZE:

The 3024 is very successful, but it is too big for some applications, especially where the customer wants to replace AC Bars with modern DC equivalents.

Customers said that they wanted a 24 V DC Bar with the same dimensions as the 1250-S Bar: 32 x 20 mm.

The dimensions of the 3014 are 32.5 x 20 mm (The 3024 is 41.5 x 22 mm).



The profiles of the 3014 and 3024

### 24 V DC:

The market for 24 V DC Bars is growing quickly because the advantages of 24 V DC are becoming valuable and desirable to OEMs and end-users worldwide:

- Most modern machines use 24 V DC to power and control ancillary equipment. In many cases AC 110 - 250 V supplies are not available where the static eliminators are to be installed.
- 24 V DC allows easy interface with the machine controls, with monitoring of status and performance.
- 24 V DC static eliminators give better performance than traditional static eliminators.
- 24 V DC means that there are no high voltage cables and external power units to be routed and sited on the machine.
- OEMs can sell 24 V equipment anywhere in the World. They do not have to be concerned with different voltages and frequencies.
- Low voltage cables are cheap to buy and easy to replace if damaged.

### PRICE:

The 3024 is too expensive to be a replacement for some AC systems, especially where they do not need its extra power / performance.

The 3014 cost has been reduced by an average of 25 % to make it the most competitively priced 24 V DC Bar on the market.

### PERFORMANCE:

The static elimination performance of the 3014 is better than any existing standard AC static eliminator.

See performance data section 4.

### 'CLEAN ME':

Customers want a signal to show that the Bar needs attention / cleaning. The 3014 shows that the system status is OK and also if the Bar needs cleaning by two methods: on the end-cap LED and also with a remote signal.

### TUNGSTEN EMITTERS:

Tungsten is the best material to withstand high voltage ion generation, but it is also expensive. The 3014 has tungsten emitters to show that it has been designed for a long and productive life. The emitters are at a 20 mm pitch.

3014-DM-Iss.2

### 3. TECHNICAL SPECIFICATION

#### Power Input

Input Voltage:	24 V DC nominal, 21-27 V range. See essential grounding requirements.
Input Current:	0.5 A max.
Maximum Input Power:	12 W.
Input Connector:	M8, 4-pole, male.

#### Output

Output Voltage:	±7.5 kV ±5%
Output Frequency:	50 Hz.
Emitter Material:	Tungsten.
Emitter Touch Current:	80 µA max. per emitter.

#### Monitoring

Status Indication Endcap LED:	Green Flashing:	OK, Bar operating normally.
	Red / Green Flashing:	Attention required.
	Red:	Supply voltage out of range or internal fault.

#### Remote Monitor

Signalling Outputs:	'OK' and 'Attention'.
Signalling Levels:	24 V output, 1.5 kΩ output impedance.
	Output current: Sourcing (+24 V): 16 mA
	Sinking (0 V): 20 mA
	Limited to 50 mA max. (output low) by internal protection.
	PLC compatibility: Compatible with IEC 61131-2 'Type 1' and 'Type 3' PLC inputs.
	Remote monitor states: Bar OK, Attention Required, Fault, Bar not powered.

#### Protection

Internal Protection:	Under-voltage lockout.
	Over-voltage lockout.
	Transient over-voltage (surge) protection.
	Reverse supply polarity protection.
	HV supplies overload protected (e.g. due to proximity earth).
	Signalling outputs protected against short circuit to +24 V or GND.

#### Environmental Conditions

Ambient Temperature:	0 to 55°C.
Relative Humidity:	Maximum 70%, non-condensing.
Ingress Protection:	IP67. Bar will not be damaged by exposure to water, but will not function correctly if the emitters are bridged by moisture.
Vibration:	Installation location must be vibration-free.

#### Mechanical

Dimensions:	20 x 32.5 mm.
Length:	From 250 mm to 4010 mm in 40 mm steps.
Weight:	0.15 kg + 0.51 kg/m e.g. 1 m Bar: 0.66 kg.
Materials:	FR-ABS, epoxy resin, tungsten emitters, steel fixings.

#### Regulatory

CE Marking:	EU LVD (2014/35/EU).
Electrical Safety:	EN 62368-1:2014.
EMC (2014/30/EU):	Emissions EN 61000-6-3:2007, Immunity EN 61000-6-2:2005.

3014-DM-Iss.2

### 3. TECHNICAL SPECIFICATION



The status of the 3014 Bar, including need for cleaning, is indicated by the LED on the endcap. Duplicate outputs enable integration with control system / PLC.

The 24VDC power supply and remote monitoring connections are made via an M8 4-pin connector. An external AC-DC PSU can be ordered if 24V DC is not available.

Mounting onto the machine is with "T" fixing which slides into the slot here.

The 3014 Static Eliminator Bar is intended for use in indoor factory environments only. It is not suitable for outdoor use.

### DIMENSIONS



3014-DM-Iss.2

---

## 4. MARKET AND APPLICATIONS

---

### WHERE IS THE MARKET FOR THE 3014?

There are two general areas:

#### Replacing and upgrading AC static eliminators.

This is a strong trend with OEMs and international manufacturing companies. They regard 24 V DC as the future of static control and do not want to use traditional static eliminators for the reasons given above.

#### New applications where a compact 24 V DC Bar is the most suitable static eliminator.

The advantages of 24 V DC technology were identified in a previous section.

However, many customers are happy with traditional AC static eliminators. They are familiar with AC technology and understand it. They see no reason to change. They also have good economic arguments on multi-Bar systems: three or four AC Bars and a power unit will cost considerably less than the same number of 24 V DC Bars. For these customers we offer both AC and DC technologies, giving objective advice on each type.

For single Bar systems the 3014 will cost less than many AC single Bar and Power Unit. It will also be more powerful.

### APPLICATIONS

The 3014 is intended as a direct replacement for the 1250-S/Super 80 AC Bar, therefore all of the potential applications are the same - short range static elimination is well understood by all of our distributors.

There are so many applications that a complete listing is impossible, the following tries to give you an idea of the range of industries and applications:

#### Plastic Film and Sheet including:

Extrusion	Bagmakers	Perforators	Sheet Cutters
Printers	Converting	Signs	Embossing
Laminators	Centre Winders	Tape Lines	

#### Plastic Mouldings including:

Blow Moulding	Thermo and Vacuum Form	Injection Moulding
---------------	------------------------	--------------------

#### Packaging, Food etc including:

Stretch Wrapping	Cigarettes	Tamper Evident	Ink Jet
Canning	Closures	Drying	Label Application
Overwrappers	Conveying	Plastic Bottles	Vertical Form Fill Seal
Shrink Sleeve	Checkweighers	Wrappers	

3014-DM-Iss.2



Scotts Business Park, Bampton, Devon, GB, EX16 9DN  
T + 44 (0) 1398 331114 F + 44 (0) 1398 331411  
E sales@fraser-antistatic.co.uk W www.fraser-antistatic.com  
© Fraser Anti-Static Techniques Ltd 2019



---

## 4. MARKET AND APPLICATIONS

---

### Paper and Printing:

Digital Printing	Label Presses	Gravure Presses	Pad Printing
Paper Products	Paper Mills	Sheet and Web Presses	Form Presses
Wallpaper Presses	Tissue	Converting	
Flexo Presses	Screen Printing	Paper Folders	

### Textile:

Carding	Narrow Fabrics	Creels	Lace Machines
Sizing	Beaming	Warping	
Inspection Machines	Stenters	Finishing	
Technical Fabrics	Transfer Printing	Non-wovens	

### General Industry:

Conveyors	Pneumatic Transport and Handling
-----------	----------------------------------

We will give further application updates as our experience with the 3014 grows.

3014-DM-Iss.2

---

## 5. PERFORMANCE, COMPETITION AND PRICING

---

### PERFORMANCE OF THE 3014 STATIC ELIMINATOR BAR

The 3014 is a short range static eliminator for distances from 20 to 150 mm. The target was for the 3014 to be more powerful than the 1250-S Bar - and so more powerful than other leading AC Bars.

The performance comparison is:

Distance	3014: % more power than 1250-S Bar
20 mm	58%
30 mm	46%
50 mm	26%
75 mm	13%

This performance is achieved partly by having clean, square wave shapes at up to 7.5 kV and partly by the innovative 'field overlap' enhancement. "Field overlap" means that both positive and negative polarities are running at the same time for a few milliSeconds. This increases the ion density and gives better neutralisation for short range and high speeds.

The performance at 20 - 50 mm is market-leading. While the performance extends to 150 mm, the customer should always try to position the 3014 Bar between 20 to 50 mm from the object.

In performance, the 3014 sits between the 1250-S and the 3024 Bars.

### COMPETITION

At the time of writing there is only one compact 24 V DC Static Eliminator Bar known to us. This is the Meech 924 IPS.

Please see the *Competitor Analysis* report on this Bar.

The price of the Meech 924 is generally about 10% higher than our 3014 Bar.

Otherwise the completion for the 3014 comes from traditional AC static eliminator Bars.

### PRICING

The 3014 was designed to have a lower price than the 3024 Bar and single Bar AC systems.

We have achieved that.

## 6. INSTALLATION: MECHANICAL

### HANDLING

Take care when handling the Bar, particularly when removing from their packaging and installing on machinery. Avoid excessive flexing or bending of the Bar during handling.

Bars longer than 2000 mm should be handled by two people.

### LOCATION OF BAR

The most effective Bar installation location is **at or immediately before the area where static is causing a problem**, but remember that static can be re-generated by subsequent passage over rollers or through another process.

The 3014 Bar should be mounted in a clean, dry and oil-free location.

A static meter such as the Fraser 715 is useful in determining the best location for the Bar.

### POSITIONING OF BAR

Except on a winding reel of material, **the material to be neutralised should be in free air** and not touching another surface as it passes the Bar.

It is **not possible** to neutralise static where the material is touching another surface or roller.

Position the Bar such that no earthed metal parts are closer to the Bar than the material to be neutralised - earthed objects can attract ions away from the target reducing the neutralisation power and causing an ion imbalance.

The distance between the Bar and material to be neutralised is 20 mm - 150 mm. The best distance is 20 mm to 50 mm.

The emitter pins **must not be touching or close to metal objects**, for example parts of a machine.

Proximity of earthed metal objects to the Bar will reduce performance by attracting the ions emitter by the Bar. In extreme cases in spark erosion damage to the emitters and the metal object may occur.

If installation conditions are such that proximity of earthed metal to the Bar is unavoidable, avoid placing one row of emitters much closer to the object than the other. Unequal loading of the emitter pins may lead to imbalance in the ionisation output of the Bar.

### SUMMARY

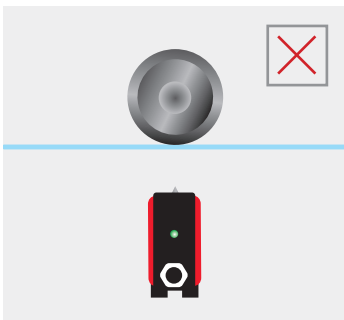

There will be very poor static neutralisation if there is not free air opposite the Bar.

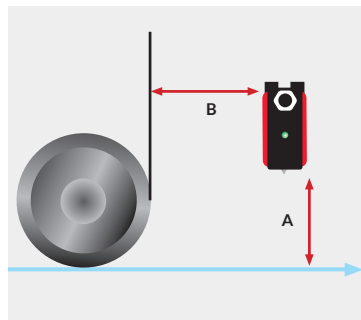

**B:** Should be  $> A$  to avoid ion loss to rollers or parts of the machine.

**A:** 20 to 150 mm.

20 to 50 mm is best for performance

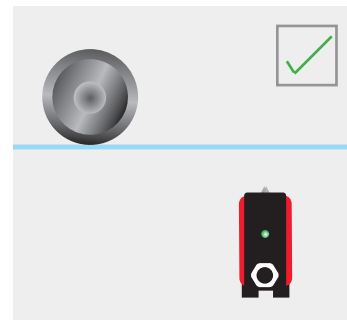

The free air opposite the Bar allows good neutralisation.

## 6. INSTALLATION: MECHANICAL

### MOUNTING OF THE BAR

The 3014 Bar uses the same T-fixings as the 3024 Bar. Use all of the T-fixings provided for mounting the Bar.

These slide in the slot in the base of the Bar.

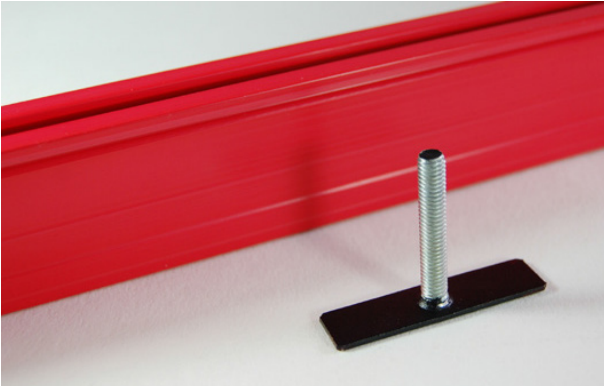

Bars up to 1000 mm in length are supplied with two fixing 'T' pieces. An additional fixing is supplied for each additional 500 mm or part thereof. For example.

850 mm: 2 fixing slides.

1300 mm: 3 fixing slides.

1800 mm: 4 fixing slides.

When mounting the Bar, the fixing slides should be distributed evenly along the length of the Bar. Do not allow more than 1000 mm of unsupported Bar between fixings.

Ideally, Bars up to 1000 mm should be mounted as shown below for a 1000 mm Bar, with half the Bar length between fixings:

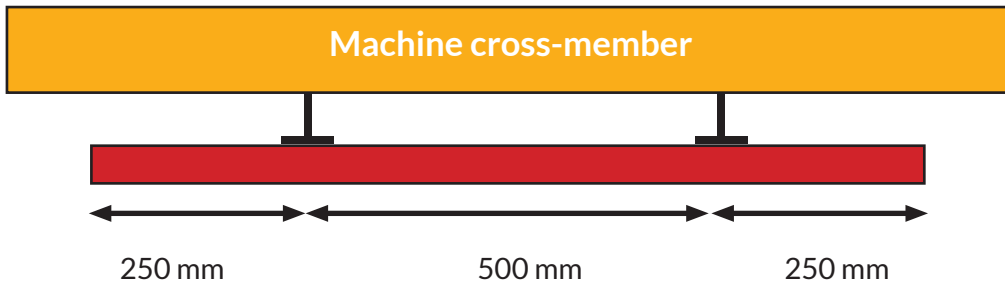

The distance between fixings should be less than 1000 mm

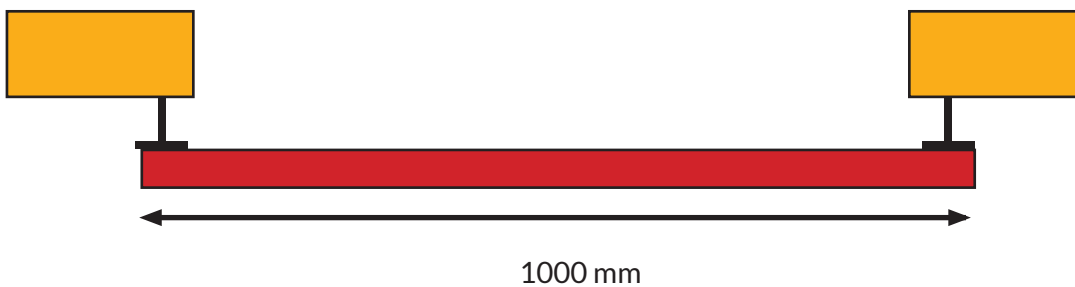

3014-DM-Iss.2

---

## 6. INSTALLATION: MECHANICAL

---

### OPTIONS AND ACCESSORIES

The 3014 is available in the following variants:

3014 AIR:	Air Bar Attachment
5114:	Mounted on 5100 Airknife
5514:	Mounted on 5500 Airknife

The 3014 has the same cables, power supply and fixing brackets as the 3024 Bar.

However, please note that the 3014 has different wiring to the 3024. This is to accommodate the 'clean me' feature. See instructions.



---

3014-DM-Iss.2

## 7. INSTALLATION: ELECTRICAL INSTALLATION AND MONITORING

This section describes the electrical installation of the 3014 Compact Static Eliminator Bar and the functioning of its remote monitoring interface.

Wiring examples are provided for common installation types.

### ELECTRICAL CONNECTIONS

**Do not connect or disconnect the M8 cable when powered. Risk of electric shock and/or damage to the Bar.**

All electrical connections to the Bar are made via the M8 4-pole connector on the endcap of the Bar. The Bar is fitted with a male connector; a cable with a female (socket) connector is required. For suitable connection cables, see section 13 of this document.

- If using the Fraser Anti-Static Techniques external power supply unit (p/n 3024-PSU), simply connect the M8 cable from the power supply to the Bar and ensure that the supplementary ground wire is connected to installation protective earth before connecting mains power.
- If using a separate 24 V power supply and cable (e.g. as part of a machine control cabinet installation), follow the instructions below for connecting the Bar.

The M8 connector pin numbering scheme is shown below.

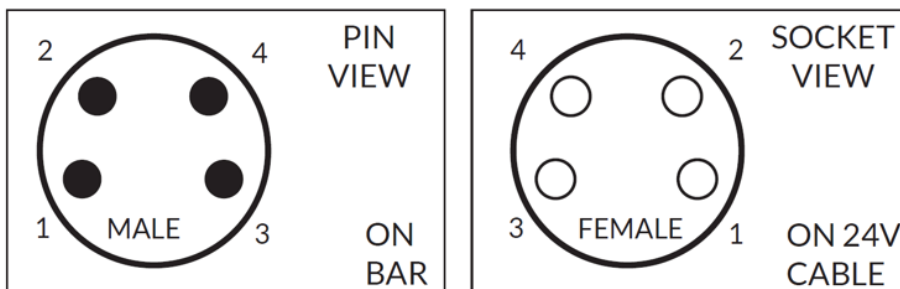

The pin assignment and typical wire colour is given in the table below.

Note that if using self-supplied M8 cables, the wire identification may vary. The colour assignments below are typical of M8 'sensor/actuator' cordsets. Cordsets intended for fieldbus applications or power delivery may be different.



Pin	Wire Colour	Function	Details
1	Brown	+24 V	21 – 27 V operating range, 0.5 A maximum current.
2	White	OK signal	+24 V nominal output voltage, 3 k $\Omega$ output impedance in active state. Low impedance connection to 0 V in inactive state. See Appendix II for details.
2	Blue	0 V + GND	0 V must be connected to ground.
4	Black	ATTENTION signal	+24 V nominal output voltage, 3 k $\Omega$ output impedance in active state. Low impedance connection to 0 V in inactive state. See Appendix II for details.

3014-DM-Iss.2

## 7. INSTALLATION: ELECTRICAL INSTALLATION AND MONITORING

### POWER SUPPLY CONNECTIONS

The diagram below shows the power supply connection requirements when using a 24 V power supply **not** supplied by Fraser (e.g. as part of a control cabinet installation).

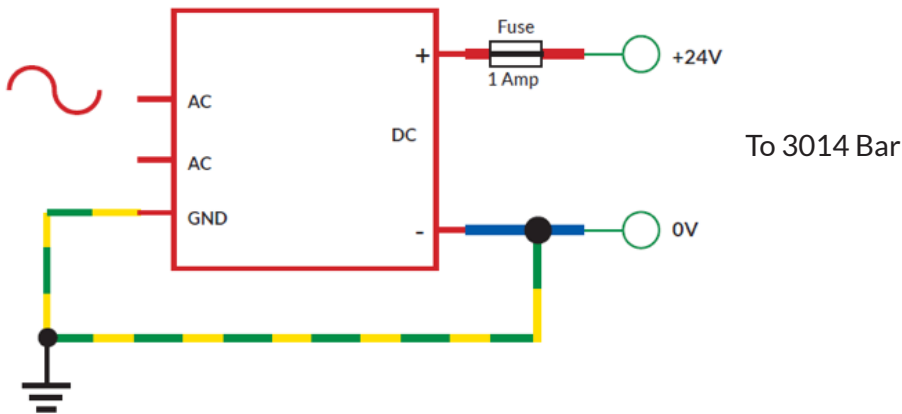

The 24 V supply connection (Pin 1, brown wire) **must** be fitted with a 1 A fuse. It is recommended that a type 'T' or 'gG' fuse is used.

The 0 V supply connection **must** be connected to installation protective earth (PE). This connection should be made at the power supply output terminal if possible. There is **no** additional grounding connection to the Bar – it is **essential** that this connection is made externally.

### IMPORTANT WARNING - GROUNDING

If the 0 V output of the DC power supply is not grounded, there is a risk of the operator receiving an electric shock from the M8 connector on the Bar.

If the 0 V output of the DC power supply is not grounded, damage may occur to the power supply and/or the Bar.

If the 0 V output of the DC power supply is not grounded the residual voltage (balance) level of the Bar cannot be guaranteed.



### POWERING THE BAR DIRECTLY FROM A PLC DIGITAL OUTPUT

A typical 24 V, 0.5 A output from a PLC is capable of supplying the maximum current required by the Bar, and can be used to power the Bar directly.

It is possible that over-current trips may be experienced on PLC outputs due to the pulsing of the HV supplies in the Bar. This will depend on the characteristics of the PLC output module. In this case, use the PLC output to control a relay which switches the main 24 V supply to the Bar.

3014-DM-Iss.2

## 7. INSTALLATION: ELECTRICAL INSTALLATION AND MONITORING

### POWER SUPPLY CABLE REQUIREMENTS

If using a self-supplied M8 cable to power the Bar, ensure that the voltage drop along the cable is not excessive. This is unlikely to be an issue except in cases with very long cables between the power supply and Bar, or where the power supply output voltage is close to the lower limit of 21 V.

At 0.5 A, each 10 metres of 0.25 mm<sup>2</sup> (24 AWG) cable causes a round-trip voltage drop of approximately 0.8 V. Cables of this specification with lengths of up to 30 metres are unlikely to cause issues when the supply voltage is 24 V.

### REMOTE MONITORING INTERFACE

The Bar is equipped with a remote monitoring interface which allows the operating status of the Bar to be fed into a PLC system or checked remotely.

The electrical specifications and signalling scheme of the remote monitoring interface differ from those of other Fraser Anti-Static Techniques 24 V Static Eliminator Bars (3024 and NEOS series). Please read these instructions carefully before installing the Bar.

### REMOTE SIGNALLING SCHEME

The remote monitoring interface has two output signals, OK and ATTENTION. The signalling convention employed is ACTIVE (+24 V nominal) = OK, INACTIVE (0 V) = NOT OK.

The signalling scheme is described in the following table:

Condition	Ionisation	OK (White, Pin 2)	Attention (Black, Pin 4)
Bar powered, all OK	ACTIVE (HV ON)	ACTIVE (24 V)	ACTIVE (24 V)
Bar powered, requires attention (e.g. cleaning)	ACTIVE (HV ON)	ACTIVE (24 V)	ACTIVE (24 V)
Overload, hardware fault, supply voltage out of range	INACTIVE (HV OFF)	INACTIVE (0 V) Will sink current	INACTIVE (0 V) Will sink current
Bar not powered	INACTIVE (HV OFF)	INACTIVE (0 V) Will sink current	INACTIVE (0 V) Will sink current

The OK output always directly indicates the ionisation state of the Bar.

Because the outputs are implemented using an electronic switch rather than a relay, when the Bar is not powered, the outputs will not sink current.

## 7. INSTALLATION: ELECTRICAL INSTALLATION AND MONITORING

### REMOTE INTERFACE ELECTRICAL SPECIFICATIONS

The OK and ATTENTION signals are provided by open-collector outputs with an internal pull-up resistor within the Bar. They are designed to allow direct connection to PLC digital inputs conforming with IEC 61131-2 'Type 1' and 'Type 3' characteristics. The detailed specification of the remote signalling output is given in the table below.

Characteristic	Specification	Notes
High-level output voltage, open-circuit	$V_{IN} - 0.5 \text{ V}$	$V_{IN}$ is nominally 24 V. High-level output voltage depends on power supply voltage.
Output impedance, high-level	1.5 k $\Omega$	Internal pull-up to $V_{IN}$ .
Maximum output current, high-level, $V_{IN} = 24 \text{ V}$ (sourcing)	16 mA	Output shorted to 0 V.
Low-level output voltage, open-circuit	0 V	Connected to 0 V by low-impedance switching device.
Output impedance, low-level	<50 $\Omega$	
Maximum output current, low-level (sinking)	20 mA	Limited by internal self-resetting fuse.
Maximum externally applied voltage	28 V	Signal output is protected against over-voltage, current limited by internal self-resetting fuse.

The simplified schematic diagram below shows the implementation of the remote signalling outputs.

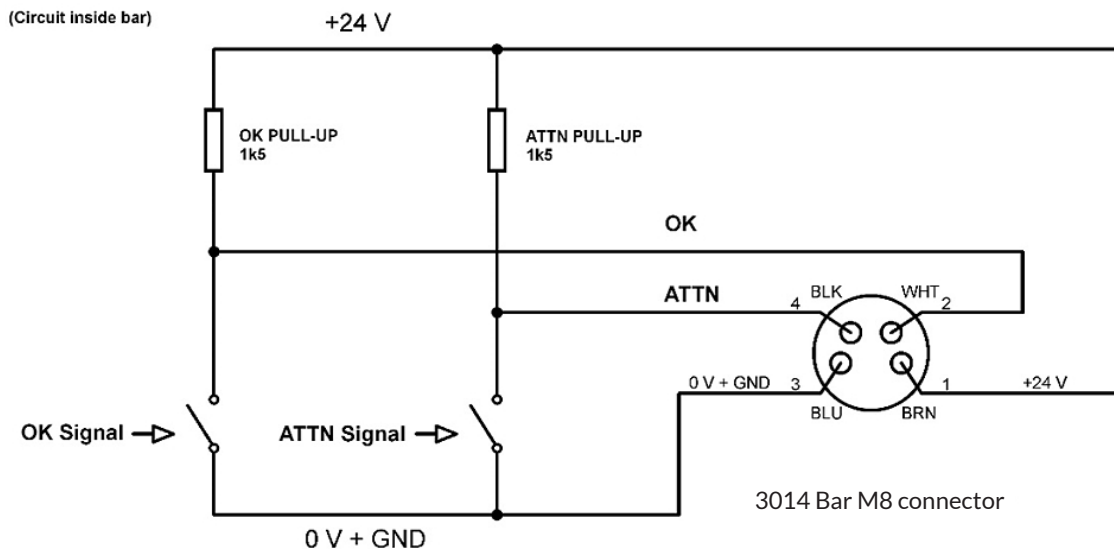

The switches in the diagram above are shown in the position corresponding to 'Bar powered, all OK'.

## 7. INSTALLATION: ELECTRICAL INSTALLATION AND MONITORING

### INTERFACING WITH PLC SYSTEMS

To interface the Bar with a PLC digital input conforming with IEC 61131-2 'Type 1' and 'Type 3' characteristics, simply connect the 'OK' and/or 'ATTENTION' outputs from the Bar to the PLC digital input module. This is shown in the diagram below.

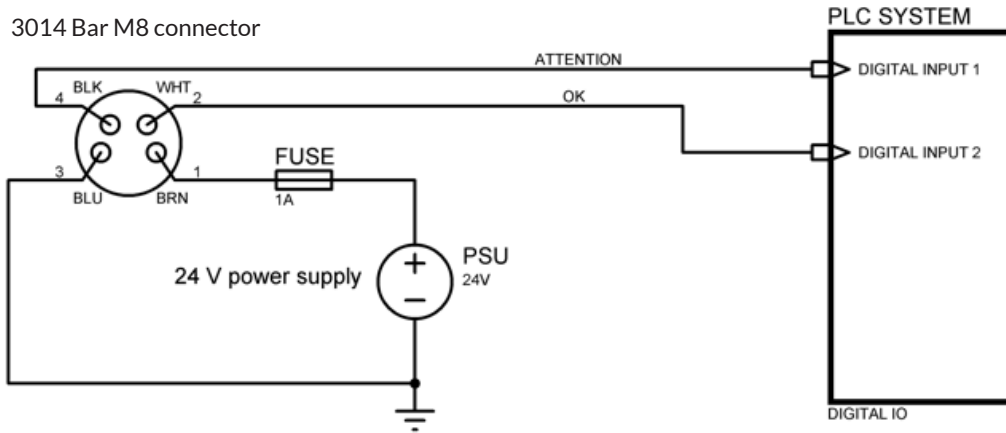

To interface the Bar with a PLC system having IEC 61131-2 'Type 2' input characteristics, fit an external 1 k $\Omega$  pull-up resistor to supply the current required by these input types, as shown below. These resistors should have a power rating of at least 1 W.

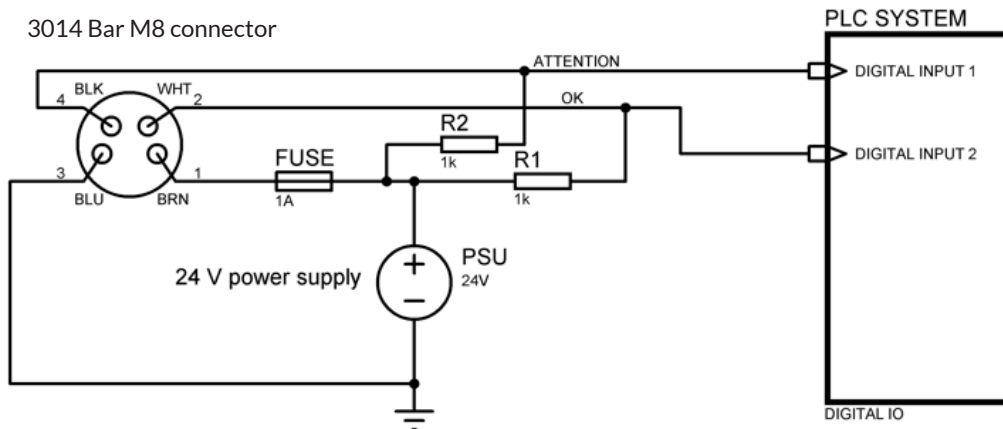

If external 1 k $\Omega$  pull-up resistors are fitted, these should have a power rating of 1 W or more. Note that these resistors will become hot in operation and should be installed with consideration given to their operating temperature.

### POWERING THE BAR DIRECTLY FROM A PLC DIGITAL OUTPUT

A typical 24 V, 0.5 A PLC output is capable of supplying the average current required by the Bar, and can be used to power the Bar directly.

It is possible that over-current trips may be experienced on PLC outputs due to the pulsing of the HV supplies in the Bar. This will depend on the characteristics of the PLC output module. In this case, use the PLC output to control a relay which switches the main 24 V supply to the Bar.

3014-DM-Iss.2

## 7. INSTALLATION: ELECTRICAL INSTALLATION AND MONITORING

### CONNECTING EXTERNAL INDICATORS

The 24 V signalling outputs of the Bar can be used to drive indicator lamps directly, but are limited in their output current **sourcing** capability. Testing has shown that acceptable brightness is achieved with typical 24 V LED-based industrial indicators with rated current of 20 mA or less when the signal output is **sourcing** current. Full brightness will be obtained when the signal output is **sinking** current.

The recommended wiring scheme for external indicators is shown below. Note that the connections for the OK and ATTENTION signals are different.

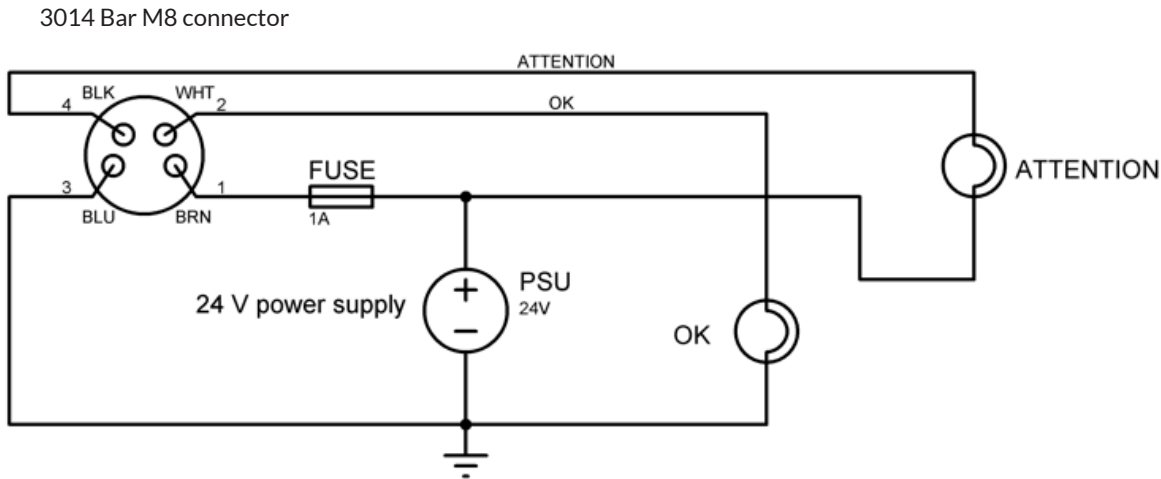

With this wiring scheme, the indicators will illuminate according to the table below.

Bar Status	OK Indicator	ATTENTION Indicator
Powered, all OK	ON	OFF
Attention required	ON	ON
Fault, overload, supply voltage out of range	OFF	ON
Bar not powered	OFF	OFF

Connecting indicators with higher current requirements to the Bar will not damage it, but it is unlikely that satisfactory brightness will be obtained.

## 7. INSTALLATION: ELECTRICAL INSTALLATION AND MONITORING

### CONNECTING EXTERNAL RELAYS

If it is necessary to provide potential-free contacts or to switch a higher voltage or current level, an external relay can be installed between the Bar and signalling circuit.

External relays must be connected such that the Bar output **sinks** current to energise the relay coil. The output current capability of the signalling outputs when **sourcing** current is not sufficient to drive a relay coil.

PLC interfacing relays with high-sensitivity 24 V DC coils should be used to interface with the Bar. Some examples are:

- Phoenix Contact PLC-RSC series.
- Finder 38 series.
- Wieland FLARE-24DC series.
- Omron G2RV series.

Relay coil current at 24 V should not exceed 20 mA.

External relays should be fitted with coil suppressors.

The recommended wiring scheme for external relays (using SPCO relays) is shown below.

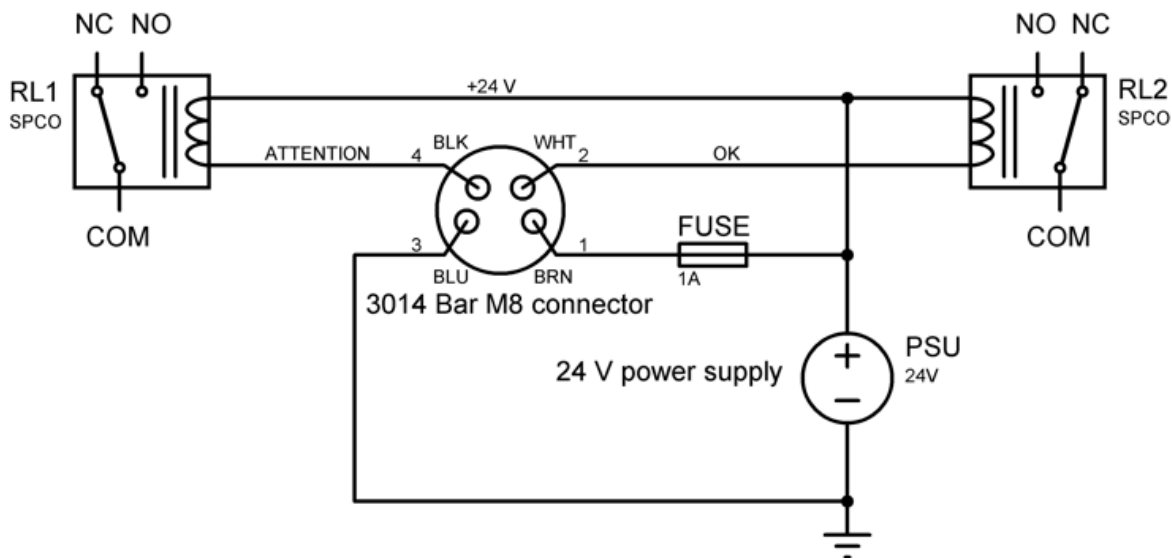

The relay contacts will be connected according to the following table.

Bar Status	OK Relay (RL2)	ATTN Relay (RL1)
Powered, all OK	OPEN (COM → NC)	OPEN (COM → NC)
Attention required	OPEN (COM → NC)	CLOSED (COM → NO)
Fault, overload, supply voltage out of range	CLOSED (COM → NO)	CLOSED (COM → NO)
Bar not powered	OPEN (COM → NC)	OPEN (COM → NC)

Due to the use of electronic switches within the Bar, it is not possible to determine remotely that the Bar is not powered when using external relays.

3014-DM-Iss.2

---

## 8. OPERATION, MAINTENANCE AND SAFETY

---

The 3014 Compact Static Eliminator Bar has no settings requiring adjustment. This section describes commissioning the Bar for use, and explains the LED status indication.

The operation of the integrated remote monitoring function is described in section 7 (electrical installation).

### COMMISSIONING

Before turning the Bar on for the first time, ensure that:

- The positioning and mounting of the Bar is in accordance with the instruction in section 6 of this document.
- The electrical installation of the Bar has been completed in accordance with the instructions given in section 7 of this document. In particular, ensure that the 0 V output of the 24 V supply is grounded to the installation point.
- If using the external AC-DC power adaptor, ensure that the supplementary grounding wire is connected to the installation earth.
- The Bar is clear of any moving parts which may damage it when the machine or process is in operation.
- Any operators who will work in close proximity to the Bar are aware of its presence and familiar with its operation.

The Bar may now be powered up for the first time.

### LED

The 3014 Compact Static Eliminator Bar is equipped with a bi-colour LED indicator on its endcap, located above the M8 power/signal connector. The LED indicates the operational state of the Bar.

When the Bar is first powered, the LED will illuminate **RED** for up to three seconds. If the Bar is in good working order, the LED will then illuminate **GREEN** to indicate normal operation.

In normal operation the LED will illuminate solid **GREEN**. This shows that all internal measured parameters are within their nominal ranges and that ionisation is being generated.

If the Bar detects an increased level of current being drawn from the emitter pins, indicating the presence of contamination, the LED will flash alternately **GREEN** and **RED**. The ionisation remains active, but neutralisation effectiveness of the Bar may be reduced.

In this case, the Bar should be powered off when convenient and cleaned as described in section 12 of this document.

**Note that certain types of insulative contamination may not trigger the 'cleaning required' indication. The Bar should be checked regularly for cleanliness of the emitters.**

If the Bar detects a fault condition, the LED will illuminate solid **RED**. The ionisation will be disabled in this state. This condition may be caused by:

- Supply voltage outside of normal range (below 21 V or over 28 V).
- High voltage supplies overloaded (e.g. by earthed object close to emitters).
- Internal fault within the Bar.

In this case, the troubleshooting procedures specified in section 11 should be followed.

Summary:

The LED on the endcap of the Bar shows:

Green:	Status OK.
Green / red flashing:	Bar needs cleaning / attention.
Red:	Fault Status - ionisation is not active.

3014-DM-Iss.2

---

## 8. OPERATION, MAINTENANCE AND SAFETY

---

### MAINTENANCE

Cleaning is the only maintenance required. The electronic components within the Bar are fully encapsulated for protection and insulation, and as such no repair is possible.

**Turn off the power supply to the Bar before performing any installation or maintenance work on the Bar.**

Dirt around the emitters will reduce ionisation effectiveness and result in unsatisfactory static neutralisation performance. Dirt on the extrusion body may allow energy to track to earth.

The frequency of cleaning will depend on the nature of the process(es) run on the machine the Bar is mounted on, and the general environment in which the Bar is installed. The Bar should be cleaned when an 'attention required' status is indicated by the endcap LED and/or remote monitoring interface.

To ensure best performance, the Bar should also be visually inspected on a regular basis and cleaned whenever convenient to do so. As discussed earlier in this manual, certain types of contamination may not trigger the 'attention' signal e.g. if the contamination is heavily insulative.

**The emitter pins of the Bar are very sharp, in order to obtain good ionisation performance. Take care to avoid injury when cleaning the Bar.**

A Bar cleaning kit is available from Fraser Anti-Static Techniques, part number **81220**. This is the ideal solution for regular Bar cleaning, but alternatively a toothbrush or soft nail brush can be used to clean the Bar. Do not use a wire brush as this may cause damage to the Bar.

When cleaning the Bar, ensure that the emitters, the resin surface around the emitters and the Barrier between emitter rows are all cleaned thoroughly.

The Bar can be cleaned with water and a gentle detergent, or iso-propyl alcohol (IPA), but it must be dry around the emitters before turning the power on again.

Keep the Bar dry and free of dust, dirt, oil, corrosive substances and solvents.

### SAFETY

Installation and maintenance work on the Bar must only be carried out by suitably qualified personnel.

The Fraser 3014 Bar is a pulsed DC Static Eliminator Bar, with 24 V power input. It has been designed in accordance with the safety requirements of EN 62368-1:2014 (Audio/video, information and communication technology equipment, Part 1: Safety requirements). This standard is harmonised under the EU Low Voltage Directive and recognised by UL. This standard supersedes EN 60950-1:2006, against which the 3024 Bar was certified. Its technical requirements are very similar, but the method of safety assessment used differs. If there are any questions about this please contact us.

**Emitter Pins:** The emitter pins of the Bar are protected by suitably-rated current-limiting resistors such that they may be considered a **Class 1** electrical energy source, as defined in EN 623681:2014. This means that contact with the emitter pins is not painful and will not result in an electrically-caused injury, but may cause a detectable sensation due to the small current which will flow.

The emitter pins of the Bar are necessarily sharp in order to perform their intended function. The emitter pins are considered a **Class 2** mechanical energy source, as defined in EN 623681:2014. This means that contact with them may be painful, but will not cause an injury requiring emergency medical attention.

**Ozone:** A small amount of ozone will be produced as part of the ionisation process. When installed correctly the level of concentration of ozone is less than 0.1 ppm and is within internationally accepted limits.

**Shocks to Personnel:** As with all pulsed DC Static Eliminators, it is possible for the user to receive a small static shock as a result of their body being charged by the Bar, and then discharging to a nearby earthed object. This is not dangerous, but may be uncomfortable and cause surprise.

**Essential:** It is worth repeating, because some installers ignore these important rules:

- the negative pole of the 24 V DC supply provided to the Bar **must** be *permanently earthed*.
- Adequate installation earth / ground is required to ensure safe and proper operation.

3014-DM-Iss.2

## 9. TROUBLESHOOTING

In the event of difficulties with the Bar, please use the following checks to assist with diagnosing and correcting the issue.

Symptom	Cause(s)	Solution(s)
No LED	Bar not powered.	<ul style="list-style-type: none"> <li>• Check power supply and connections.</li> <li>• Check fuse.</li> <li>• Check supply cable for damage.</li> </ul>
Red LED	Power supply voltage outside of specified range.	<ul style="list-style-type: none"> <li>• Check and adjust power supply voltage.</li> <li>• Ensure appropriate power supply cable used.</li> <li>• Ensure power supply not overloaded.</li> </ul>
	HV supplies overloaded.	<ul style="list-style-type: none"> <li>• Check Bar installation.</li> <li>• Move Bar further from earthed metal objects.</li> <li>• Check Bar for damage.</li> </ul>
	Internal fault.	<ul style="list-style-type: none"> <li>• Contact supplier.</li> </ul>
Red/Green LED	Emitters need cleaning.	<ul style="list-style-type: none"> <li>• Power off and clean Bar.</li> </ul>
	Bar installed too close to machine parts.	<ul style="list-style-type: none"> <li>• Check Bar installation.</li> <li>• Move Bar further from metal parts.</li> </ul>
Poor Ionisation/ Neutralisation Performance	Emitters need cleaning.	<ul style="list-style-type: none"> <li>• Clean Bar.</li> </ul>
	Emitters worn.	<ul style="list-style-type: none"> <li>• Check emitters for excessive wear.</li> <li>• Replace Bar.</li> </ul>
	Bar installed too close to machine parts.	<ul style="list-style-type: none"> <li>• Review installation, move Bar away from machine parts if possible.</li> </ul>
	Bar installed too far from material to be neutralised.	<ul style="list-style-type: none"> <li>• Review installation, move Bar closer to material if possible.</li> </ul>
	Bar installed opposite roller/machine parts.	<ul style="list-style-type: none"> <li>• Review installation, move Bar opposite material in free air if possible.</li> </ul>

3014-DM-Iss.2

## 10. ACCESSORIES AND SPARE PARTS



A range of accessories to assist with installation and maintenance of the Bar are available from Fraser Anti-Static Techniques.

Please contact your local distributor to enquire regarding pricing and delivery of these items.

Item Photo	Description	Part Number
	3 m cable M8 female, Bare ends. Straight socket.	80892
	5 m cable M8 female, Bare ends. Straight socket.	80930
	7.5 m cable M8 female, Bare ends. Straight socket.	80931
	10 m cable M8 female, Bare ends. Straight socket.	80932
	3 m cable M8 female, Bare ends. 90° socket.	80933
	5 m cable M8 female, Bare ends. 90° socket.	80934
	7.5 m cable M8 female, Bare ends. 90° socket.	80935
	10 m cable M8 female, Bare ends. 90° socket.	80936
	Universal AC/DC power supply. 100-250V AC, 24V DC output. Fitted with 1.5m of cable.	E3024-PSU

3014-DM-Iss.2

## 10. ACCESSORIES AND SPARE PARTS

Item Photo	Description	Part Number
	<p>2 m M8 male to M8 female 4-pin extension cable for AC/DC power supply unit.</p>	<p>80937</p>
	<p>Mounting 'T' Bracket, including flanged nut. 40 mm stud length, M6 thread.</p>	<p>30248</p>
	<p>Fraser Ioniser Cleaning kit containing:</p> <ul style="list-style-type: none"> <li>• 500ml of Cleaning Fluid.</li> <li>• Soft bristle hand brush.</li> <li>• Instructions for use.</li> </ul>	<p>81120</p>