

3024 DC RING IONISER

A compact in-line static eliminator to neutralise charged material in pneumatic transport and polymer handling systems.

The novel integration of high voltage DC ionisation with air assistance provides the most powerful static neutralisation to avoid static-induced blockages and product misbehaviour in pipework, air separators and discharge areas.

PERFORMANCE

- 11 kV of ionising power delivered by an external 24 V DC power unit, which is included with the Ring Ioniser.

ESSENTIAL QUALITIES

- DC ionisation separates polarities to provide ions with a longer and more effective life in eliminating static charge in the pipework.
- Air assistance blows the ions into the centre of the pipework for optimal product neutralisation.
- Available in 3 versions: 150 mm, 200 mm or 250 mm flange coupling for installation with standard Jacob tubing.

CONNECTIVITY AND CONTROL

- LED on body of power unit shows operational status.

APPLICATIONS

- Positioned immediately before critical sections of pneumatic transport systems, the 3024 DC Ring Ioniser neutralises the charge in the product to prevent problems at corners, air separators, cyclones and discharge points.
- Widely used in polymer feeding and mixing processes.



SPECIFICATION

Construction:

PVC/steel body, stainless steel HV electrodes.

Diameter:

For 150 mm, 200 mm or 250 mm OD Jacob tube.

Output Voltage:

11 kV supply via a separate power unit (included).

Local Status Indication:

Top-mounted bi-colour LED on power unit. Green = OK, Red = Fault.

Electrical Input:

24 V DC (21 - 28 V), maximum current required 0.5 A. M8 x 4-pin connector.

Air Supply:

5 Bar max. pressure. Air fitting 8 mm push fit.

Environmental:

0 - 60 °C temperature, 70 % rH non-condensing max. IP60.

Certification:

CE.

Options:

90 - 250 V AC Power Supply (Part No. E3024-PSU).*
Cable options as detailed on 3024 DS.

* Do not use ANY other standard power supplies with this product. Third party power supplies WILL cause damage and void warranty.

DIMENSIONS AND CONSTRUCTION

3024 DC Ring Ioniser

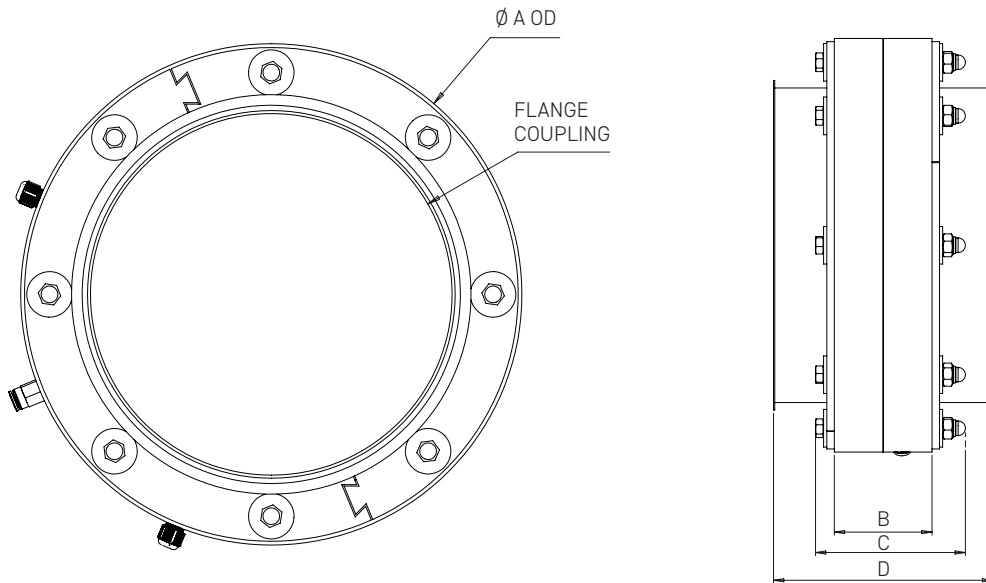

Jacob Tube (OD)	Product Code	A	B	C	D	Weight
150 mm	302414-150	235 mm	78 mm	120 mm	175 mm	6.0 kg
200 mm	302414-200	280 mm	78 mm	120 mm	175 mm	7.5 kg
250 mm	302414-250	330 mm	78 mm	120 mm	175 mm	8.0 kg

Power Unit

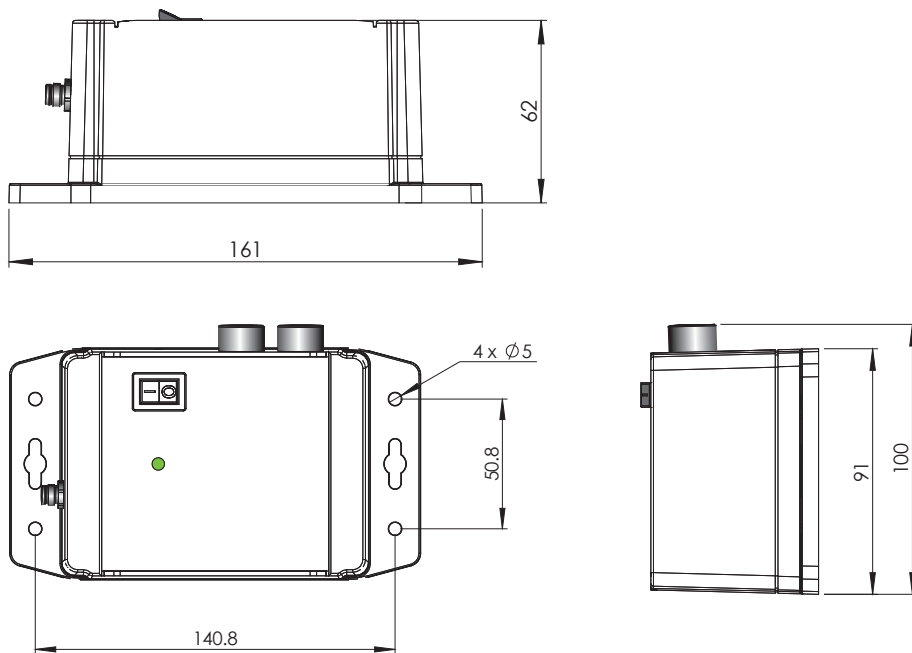

Not to scale.