



3024
DC RING IONISER



Fraser static control equipment has been designed to give you many years of productive service. However, the science of static control has unique rules which must be followed to allow the equipment to give a good return on your investment.



Please read the following operating and maintenance instructions carefully.

Contents	Page
1 Introduction	4
2 Checking On Delivered Equipment	5
3 Safety	6
4 Technical Specification and Dimensions	8
5 Mounting and Installation	13
6 Maintenance	17
7 Troubleshooting	18
8 Warranty	18
9 Certification and Declaration of Conformity	19
10 Spare Parts and Accessories	19

1. Introduction

1.1. The Equipment

The Fraser 3024 DC Ring Ioniser is a high-performance static eliminator designed to be incorporated into pneumatic transport pipework systems to neutralise the build-up of static electricity.

The 3024 DC Ring Ioniser is designed to be clamped into existing pipework.

An external Power Unit converts 24 V DC input voltage to high voltage which is transmitted to the 3024 DC Ring Ioniser by HV cable. The electrodes in the Ring Ioniser use the high voltage to produce a thick cloud of ionised air, dense with positive and negative ions to neutralise static charges.

Compressed air can be used to increase the static elimination performance of the Ring Ioniser and to help keep the high voltage electrodes clean.

1.2. Applications

The 3024 DC Ring Ioniser is used to discharge the following products:

- material granules
- film shreds
- dust

Static electricity is generated by the interaction between the products, the air and the inner walls of the transport system pipework. Generally, plastics and very dry products are more susceptible to static generation. While plastic pipes will produce more static electricity than metal pipes, it is the nature of the product being transported which determines the severity of the problem. The static generation is a continuous process in the transport system - so positioning of the 3024 DC Ring Ioniser is important. It should be positioned just before the problem area to prevent re-generation of the charge.

The 3024 DC Ring Ioniser is designed for internal use. Contact the factory for additional options.

For best performance, connect compressed air for maximum electrostatic charge removal and to prevent the electrodes from clogging with dust.

2. Checking the Delivered Equipment

The equipment leaves our factory in suitably protective packaging. Please check that it is undamaged when it arrives. If there is visible damage, contact the factory or one of our distributors immediately, before carrying out any installation.

Check that the parts which have been delivered are the same as you ordered.

3. Safety

Proper Use

Only intended for internal factory applications.

Must only be used with a suitable Fraser Power Unit.

Not certified for use in hazardous areas. For these areas see Fraser EX certified products.



Designed exclusively for operation with oil-free, dry and filtered compressed air conforming to the minimum standard specified by ISO 8573-1:2010 Class 1.4.2.

Ambient temperature must not exceed 60 °C.

Faulty air hoses and connectors can cause serious injury. Only install compressed air hoses when depressurised.



Noise levels must be checked in final installation and operating air pressure.

Identification of Hazards

Fraser designs and manufactures this equipment using the latest technology and safety information. However, all high voltage equipment should be treated with care and only installed and maintained by qualified engineers who have read and understood these instructions.

WARNING!

Please pay particular attention to parts of this manual marked with this symbol which indicate potential safety hazards.



Ozone

The emission also produces a small amount of ozone which may be detectable by a sensitive nose. This ozone level is considerably below the international safety limit of 0.1 ppm. If the smell is undesirable, then increase the level of ventilation.

Dust and Contamination

The electric field produced by the emission may attract dust from the atmosphere. It can also cause a blackening of the plastic extrusion due to carbonisation. Both the dust attraction and carbonisation are normal. See Maintenance for cleaning of Ring Ioniser.

3. Safety

Interlock with Process

Although the equipment is designed for continuous operation, we recommend that its operation is linked with the running of the machine or process, so that the system is not running when it is not needed. This will reduce dust attraction and so reduce maintenance.

Sharp Emitters

Please note that the high voltage electrode emitter pins are designed to be sharp! They could cut fingers if handled without care.



High Voltage

The emitter pins are resistively coupled to the high voltage supplies. The emitters are a Class 1 electrical energy source. Contact with the emitters is not painful and will not result in electrically-caused injury, but may cause a detectable sensation due to the small current which will flow.

As with all pulsed DC static eliminators, it is possible for the user to receive a small static shock as a result of their body being charged by the bar, and then discharging to a nearby earthed object. This is not dangerous, but may be uncomfortable and cause surprise.



4. Technical Specification and Dimensions

4.1. 302414-150 Ring Ioniser

Dimensions

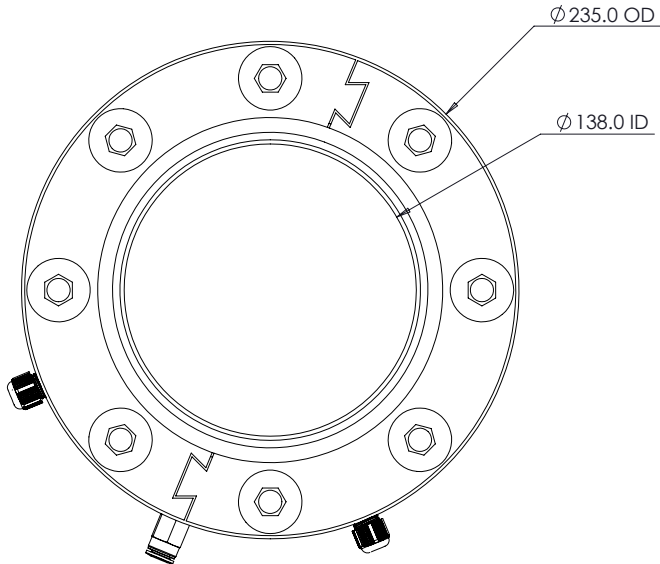

302414-150 Top View

4. Technical Specification and Dimensions

4.1. 302414-150 Ring Ioniser

Dimensions

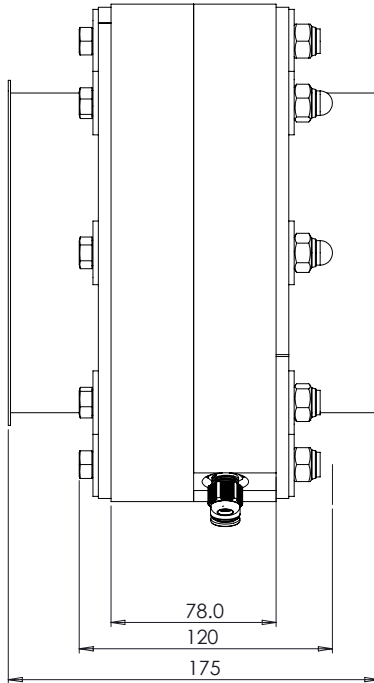

302414-150 Side View

4. Technical Specification and Dimensions

4.2. 302414-200 Ring Ioniser

Dimensions

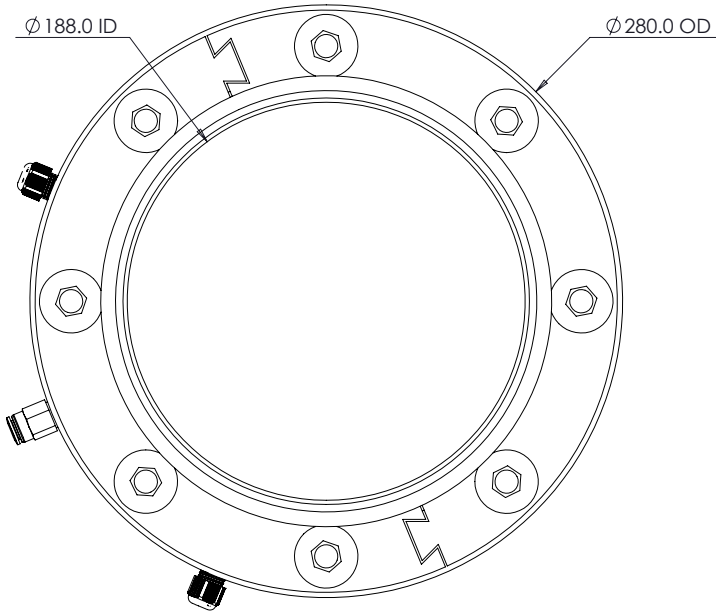

302414-200 Top View

4. Technical Specification and Dimensions

4.2. 302414-200 Ring Ioniser

Dimensions

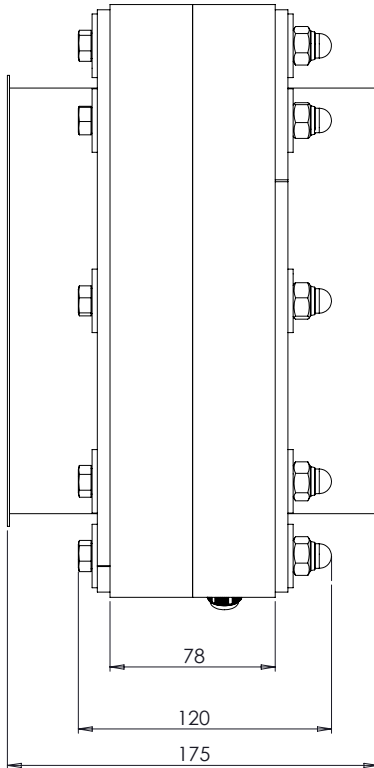

302414-200 Side View

4. Technical Specification and Dimensions

4.3. 302414-250 Ring Ioniser

Dimensions

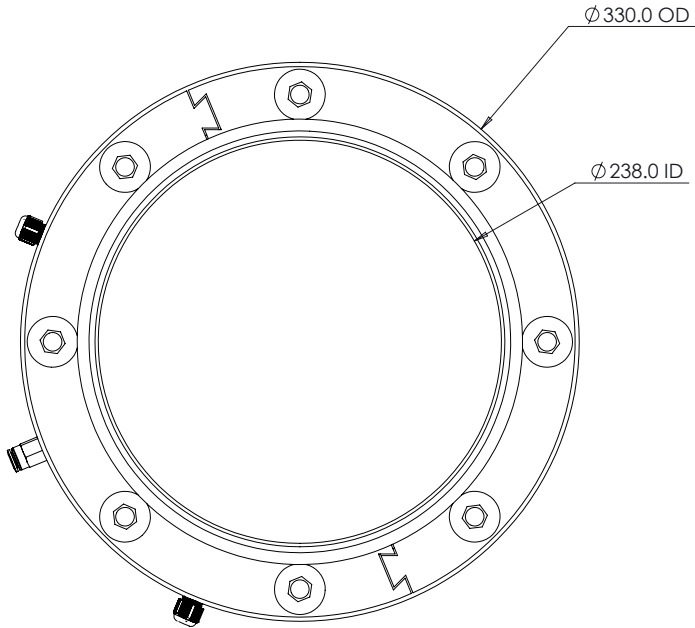

302414-250 Top View

4. Technical Specification and Dimensions

4.3. 302414-250 Ring Ioniser

Dimensions

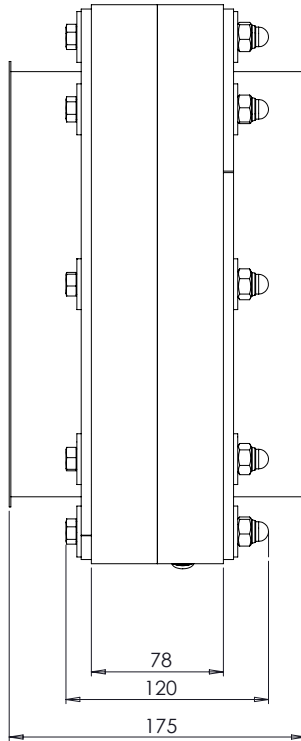

302414-250 Side View

4. Technical Specification and Dimensions

Technical Specification (Ring Ioniser)

Description	Value
Size	175 mm x 280 mm
Weight	7.5 kg
Mounting	200 mm Jacob tube flange
Compressed Air Inlet	8 mm push in, quick fit (Festo)
Compressed Air Pressure	0 - 5.0 BAR MAXIMUM. DO NOT EXCEED THIS LEVEL
Compressed Air Quality	Designed exclusively for operation with oil-free, dry and filtered compressed air conforming to the minimum standard specified by ISO 8573-1:2010 Class 1.4.2.
Sound Pressure	High sound pressure levels are generated by the release of compressed gas. Typically 70 dBA at 1 m at 3.5 Bar. Higher levels are possible depending on installation configuration. These levels must be checked for operator safety in application, and appropriate safeguards installed as necessary.
Protection Rating	IP60 (Dust Proof)
HV Electrodes	Stainless steel
Construction	PVC, steel
HV Cable	Special screened HT Cable with polyester braided sleeving Nominal diameter 6 mm Min. bend diameter 70 mm Maximum length = 5 m
HV Safety	High voltage resistors between high voltage electrode and HV make the emitters shockless to touch
Ambient Conditions	0 °C to 60 °C Maximum humidity 70 % RH, non-condensing
Safety Certification	CE

4. Technical Specification and Dimensions

4.4. 3024 DC Ring Ioniser Power Unit

Dimensions

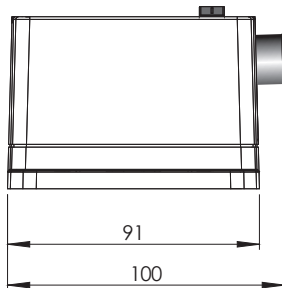
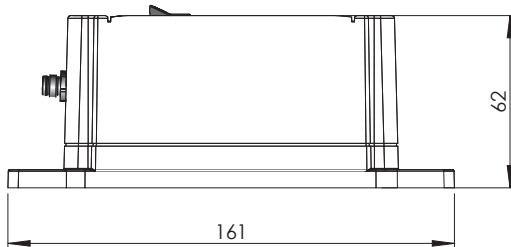
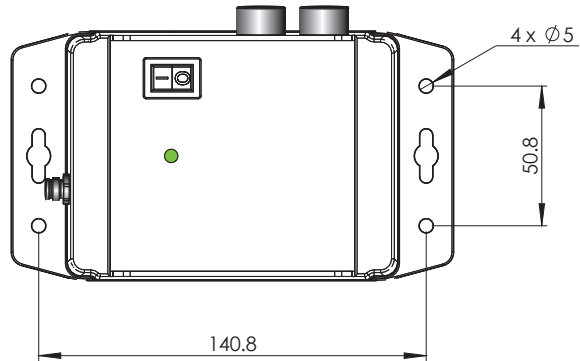

4. Technical Specification and Dimensions

Technical Specification (Power Unit)

Description	Value
Size	161 x 100 x 62 mm (L x W x H)
Weight	0.5 kg
Input Supply Voltage	24 V DC (21 - 28 V DC)
Input Current	1 A max
Output Voltage	11 kV
Output Current	< 1 mA continuous
HV Output Cable Length	5 m maximum
Status Indication	Top mounted LED. Green = OK. Red = fault.
Protection Rating	IP61 (Dust Proof)
Operating Temperature	0 °C to 60 °C
Safety Certification	CE

5. Mounting and Installation

Before installation, check for any damage during transport or handling. Installation and operation must only be performed by qualified persons observing safety warnings and complying with operator health and safety obligations.

Install only when depressurised!



1. Positioning

The best location is usually at, or immediately before, the area where static is causing the problem.

2. Cable

The high voltage flex cable is made to a high specification and must be treated carefully. Sharp bends will damage the insulation and lead to breakdown. It is very important that cable ties are not used to fix the cable (for example to an airpipe) and that the cable is not bent more than 70 mm diameter. See sketches below:

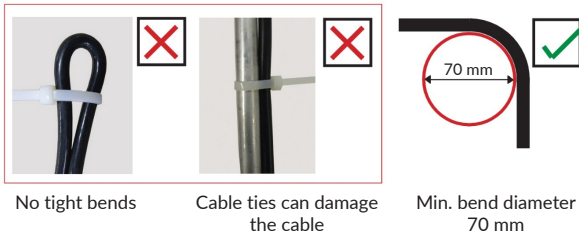

3. Air

Connect an 8 mm airline to the air inlet mounted on the side of the mounting block. Only use oil-free, dry and filtered compressed air conforming to ISO 8573-1:2010 Class 1.4.2.

Compressed air hoses should be kept as short as possible. Kinks and bends less than 3x hose diameter should be avoided. Unnecessary quick-lock couplings in the air hose should be avoided to minimise pressure loss.

5. Mounting and Installation

4. Connecting to Power Unit

Ensure power is turned off or not connected to power unit before installation.

Do not touch the white insulators - high voltage will track through any contamination on this insulator and could cause a breakdown.



5. DC Power

Use the optional Fraser AC-DC power supply: Fraser Part No. E3024-PSU M8 4-pin 24 V PSU

or

Using an existing 24 V DC supply:

The 3024 DC ring ioniser Power Unit is powered by 24 V DC.

The connector on the power unit is a 4-pole M8 male flange plug. It is compatible with 4-pole M8 female cable mounted connectors such as:

Lumberg Part No. RKMV 4-07/xM (x = 2,5, or 10)

Murr Part No. 7000-08061-611 (xxx = 150, 300, 500, 750 ...)

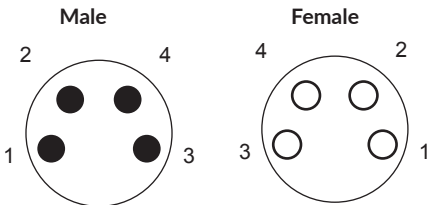

Pin	Colour	Function
1	Brown	24 V
2	White	Earth
3	Blue	0 V + Earth
4	Black	Not Used

Important: A second earth connection in addition to the earth provided by the return line on 24 V supply is required to meet international safety standards and for the correct operation of the power unit and ioniser.



5. Mounting and Installation

The 24 V output must be fitted with a 1 Amp fuse e.g. Type: 1 A, T, 250 V.

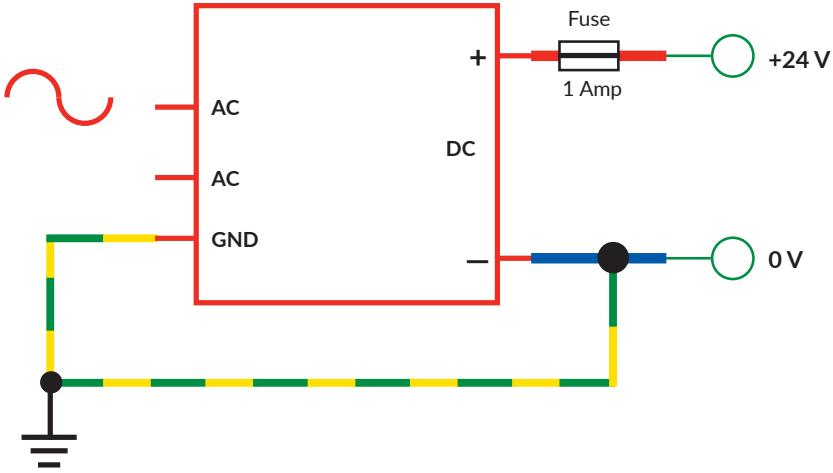

0 V of existing supply must be connected to installation ground.



5. Mounting and Installation

6. HV Output

HV Plugs

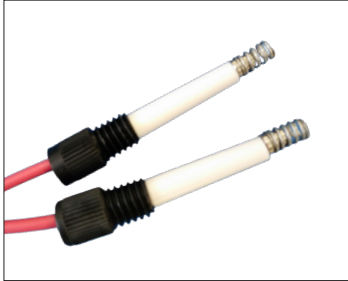

Do not touch the white insulators - high voltage will track through any contamination on this insulator and could cause a breakdown.



Completely screw into the two ports on the power unit.

When the installation has been made as the instructions in this booklet, the system is ready to turn on.

The ionised air corona produced by the emission of high voltage from the high voltage electrodes will neutralise static charge that passes through it. This is a powerful and safe process. The emission can produce a soft buzzing sound which is not usually audible in a factory.

6. Maintenance

We recommend checking installation and operation regularly, at least every 4 weeks.

Important: Turn off power and air supply before cleaning or maintenance operations.



1. Ring Ioniser

Accumulation of dust and other contaminants is normal, but this will reduce the performance of the Ioniser. It is important to clean the ionising ring to keep it working efficiently.

Light dust can be removed with a nylon brush - such as a toothbrush or nailbrush.

Ingrained dirt and carbonisation can be removed with IPA (isopropyl alcohol) or a similar solvent which is compatible with PVC, epoxy resin and aluminium. Soapy water can also be used.

Important: Do not turn on power until the Ring Ioniser is dry. Take care - the emitter pins are sharp!



2. Power Unit

No maintenance required.

7. Troubleshooting

Poor Static Elimination	<p>Check high voltage electrodes are not blocked with material.</p> <p>Clean the high voltage electrodes. Dirt around the emitters could severely affect performance.</p>
Is the Ioniser working?	<p>Try to draw a small spark to earth from the emitters, using an insulated cable with exposed conductors, or similar.</p> <p>If the Ioniser is not working it should be returned to the factory for further inspection or replacement if under warranty. There are no user-repairable parts in the Ionising Ring or Cable.</p>

8. Warranty

The warranty is for a period of 12 months from date of delivery note. It covers defective workmanship and parts provided that:

- The equipment has been used within the operating conditions specified in this document
- There has been no physical damage to the product
- The product has not been altered or tampered with
- The complete unit is sent back to the factory by the customer. The customer is responsible for these carriage costs, Fraser is responsible for returning the product repaired or replaced under warranty.

9. Certification and Declaration of Conformity



We declare that this equipment conforms to the following EC Directives:

- Low Voltage Directive: 2014/35/EU
- EMC Directive: 2014/30/EU
- RoHS Directive: 2011/65/EU

Therefore, CE Marking applied.

For further instructions, information or advice, please contact Fraser or your distributor.

10. Spare Parts and Accessories

Item Photo	Description	Part No.
	Universal AC-DC power supply: 90 - 250 V AC input. 24 V DC output. Fitted with 1.5 m cable.	E3024-PSU
	Fraser Ioniser Cleaning Kit containing: 500 ml of Cleaning Fluid Soft bristle hand brush Instructions for use	81220

For more information about static and to view the full range
of our products, please visit www.fraser-antistatic.com



Scotts Business Park, Bampton, Devon EX16 9DN, UK
T + 44 (0) 1398 331114 F + 44 (0) 1398 331411
E sales@fraser-antistatic.co.uk W www.fraser-antistatic.com