



3024 ULTRA-COMPACT 24 V DC IONISER
WITH INTEGRATED REMOTE MONITOR



Fraser static control equipment has been designed to give you many years of productive service. However, the science of static control has unique rules which must be followed to allow the equipment to give a good return on your investment.



Please read the following operating and maintenance instructions carefully.

Contents	Page
1 Introduction	4
2 Checking On Delivered Equipment	5
3 Safety	6
4 Electrical Connections	8
5 Monitoring: LED and Remote	9
6 Commissioning and Operation	10
7 Maintenance	11
8 Troubleshooting	12
9 Accessories	13
10 Appendix I: Technical Specification and Dimensions	14
11 Appendix II: Remote Interface and Wiring Examples	17

1. Introduction

The Fraser 3024 Ultra-Compact Ioniser is part of a high-performance range of static eliminators from Fraser Anti-Static Techniques. These products are used by leading manufacturers throughout the world to increase safety and productivity.

Before you install the Ioniser, please follow the installation instructions carefully for maximum benefit.

1.1. Features & Benefits

- The Fraser 3024 Ultra-Compact Ioniser is designed to neutralise electrostatically charged surfaces and small products.
- The use of Pulsed-DC high voltage provides excellent charge decay performance even at longer distances, and ion balance suitable for most industrial applications.
- Powered by 24 V DC, it features integrated high voltage supplies meaning that no high voltage cabling is required.
- The status of the 3024 Ultra-Compact Ioniser, including need for cleaning, is indicated by a single LED. An 'ATTENTION' output signal and a 'STANDBY' input signal enable integration with control system/PLC.
- The 24 V DC power supply and remote signalling connections are made via an M8, 4-pin connector. An external AC-DC PSU can be ordered if 24 V DC is not available.
- Mounting onto the machine is achieved with fixing holes integrated into the product body. Can be combined with air nozzles for cleaning functions.
- The 3024 Ultra-Compact Ioniser is intended for use in indoor factory environments only. It is not suitable for outdoor use.

1.2. Explanation of Symbols

Warning!

This symbol appearing in the operating instructions refers to operations which, if carried out improperly, may result in serious personal injuries.



Caution!

This symbol appearing in the operating instructions refers to operations which, if carried out improperly may result in damage to property.



2. Checking On Delivered Equipment

Before starting the installation please check that the 3024 Ultra-Compact Ioniser has not been damaged in transit. If the packaging material is damaged, please report this immediately to the vendor.

Check that the additional items are present with the Ioniser:

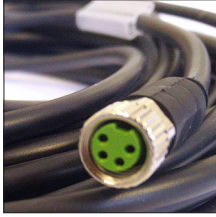

Power Supply Cable

If ordered, a 24 V power supply cable with an M8 x 4 pin connector will be supplied.

See Section 9 for details of cables and other accessories.



AC-DC Power Supply Unit

If ordered, a 24 V DC output, 100 - 250 V AC input PSU (Part No. E3024-PSU) will be supplied. The 0 V output is earthed and a secondary safety earth connection is provided.

IMPORTANT: DO NOT USE standard 'computer style' PSUs without earthed outputs to avoid risk of operator shocks and damage to the PSU or Ioniser.



3. Safety

The Fraser 3024 Ultra-Compact Ioniser has been designed in accordance with the safety requirements of the EU Low Voltage Directive.

Warnings:

- The product should be cleaned regularly. The product **should not** be cleaned while powered.
- The emitter pins are a **Class 1** electrical energy source. Direct contact with the emitter while the product is powered will not result in electrically-caused injury, but may cause a detectable sensation due to the small current which will flow.
- The emitter pins are necessarily sharp. The emitter pins are a **Class 2** mechanical energy source. Contact with the emitters during cleaning may be painful, but will not cause an injury requiring emergency medical attention.
- Installation and maintenance must only be carried out by suitably qualified personnel.
- The negative pole of the 24 V DC supply provided to the product **must** be permanently earthed. A secondary earth connection should be made to the optional air nozzle, if fitted.
- Adequate installation earth / ground is required to ensure safe and proper operation.
- Do not connect or disconnect the M8 cable from the Ioniser while it is powered.
- A small amount of ozone will be produced as part of the ionisation process. When installed correctly the level of concentration of ozone is less than 0.1 ppm and is within internationally accepted limits.



4. Electrical Connections

4.1. M8 Pin Assignments

The M8 connector pin numbering scheme is shown below. Note that due to the STANDBY input, this numbering scheme differs from other Fraser products, such as the 3024 / 3014 Bars.

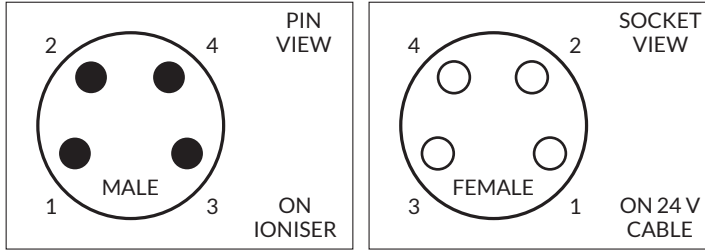

The pin assignment and typical wire colours are given in the table below. This refers to cables supplied by Fraser. Other cables may have different colour schemes.

Pin	Wire Colour	Function	Details
1	Brown	+24 V	21 – 28 V operating range, 0.25 A maximum current.
2	White	'STANDBY' Input Signal	Applying a voltage of between +21 V and +28 V causes the product to enter 'STANDBY' mode, in which the high voltage output is disabled and the LED flashes red. Either leave disconnected or connect to 0 V if not required. 5 k Ω nominal input impedance.
3	Blue	0 V and GND	0 V must be connected to ground.
4	Black	'ATTENTION' Output Signal	+24 V nominal output voltage, 3 k Ω output impedance in active state. Low impedance connection to 0 V in inactive state.

4. Electrical Connections

4.2. Power Supply Connections

The diagram below shows the power supply connection requirements when using the 24 V DC power supply on the customer's machinery.

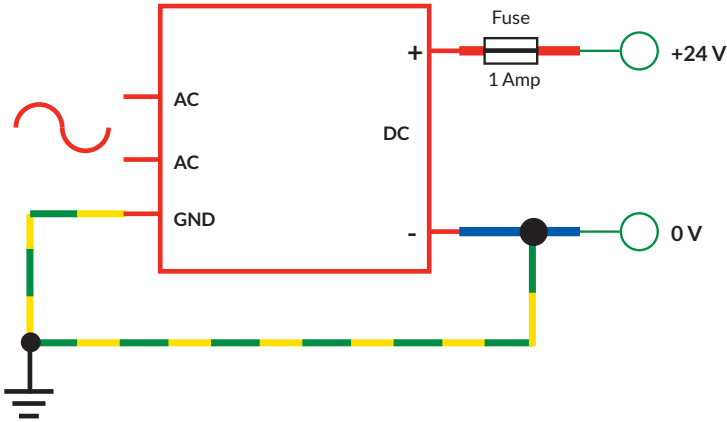

The 24 V supply connection (Pin 1, brown wire) **must be** fitted with a 1 A fuse. It is recommended that a type 'T' or 'G' fuse is installed.

The 0 V supply connection should be earthed. This connection should be made at the power supply output terminal if possible.

The earthing terminal on the product **must** be connected to installation protective earth (PE).

WARNING: If the product is not properly earthed, there is a risk of the operator receiving an electric shock from the product.

CAUTION: If the product is not earthed the residual ion balance of the product cannot be guaranteed.



5. Monitoring: LED and Remote

The LED on the loniser indicates its status as follows:

LED Indication	Ioniser Status	Ionisation
Green	OK	Active
Green/Red flashing	Cleaning/attention required	Active
Red	Overload, over temperature, hardware fault, supply voltage out of range	Inactive
Red Flashing	'STANDBY' mode	Inactive
Not illuminated	Ioniser not powered	Inactive

The loniser is equipped with a remote monitoring interface that allows the operating status of the product to be fed into a PLC system or checked remotely.

Please see Appendix II for wiring instructions and examples for the remote monitoring interface.

Please read these instructions carefully before installing the loniser, because the electrical specifications and signalling scheme of the remote monitoring interface differ from those of other Fraser 24 V static eliminator products (3014, 3024 and NEOS series bars).



6. Commissioning and Operation

Before turning the Ioniser on for the first time, check:

- The positioning and mounting of the Ioniser. The emitters of the Ioniser should face the product to be neutralised, and the emitters should both be mounted a minimum of 25 mm (ideally at least 50 mm) from an earthed metal object. Sharp metal edges within 50 mm of the emitters should be avoided.
- All metal objects, structures and surfaces in proximity to the product are earthed, such that the proximity of the high voltage emitters does not cause these objects to become electrically charged.
- The electrical installation of the ioniser has been completed in accordance with the wiring instructions in this document. In particular, ensure that the 0 V supply return is connected to earth.
- If using the external AC-DC power adapter, ensure that the supplementary grounding wire is connected to the installation protective earth.
- Any operators who will work in close proximity to the Ioniser are aware of its presence and familiar with its operation.

7. Maintenance

WARNING: Always disconnect power before working on the Ioniser.



Cleaning is the only maintenance required. Dirt around the emitters will reduce ionisation effectiveness and result in unsatisfactory static neutralisation performance.

The frequency of cleaning will depend on the process and the environment in which the Ioniser is installed. The Ioniser should be cleaned when an 'ATTENTION' state is indicated by the LED, or after approximately 1 month of continuous operation, whichever occurs first.

To ensure best performance, the Ioniser should be visually inspected on a regular basis and cleaned whenever convenient.

A toothbrush or soft nailbrush can be used to clean the high voltage emitters. Do not use a wire brush as this may cause damage to the product.

Suitable cleaning materials are warm soapy water or isopropyl alcohol (IPA). The product must be dry before the power is switched back on. For optimal cleaning results, use the Fraser Ioniser Cleaning Kit (Part No. 81220).

8. Troubleshooting

In the event of problems with the product, please use the following checks:

Symptom	Cause(s)	Solution(s)
No LED (not illuminated)	Product not powered.	<ul style="list-style-type: none"> Check power supply and connections. Check external fuse. Check supply cable for damage.
Constant Red LED	Power supply voltage outside of specified range.	<ul style="list-style-type: none"> Check and adjust power supply voltage. Ensure appropriate power supply cable used. Ensure power supply not overloaded.
	Internal fault.	<ul style="list-style-type: none"> Contact supplier.
Flashing Red LED	Product in 'STANDBY' mode.	<ul style="list-style-type: none"> Connect pin 2 of the M8 connector (usually white wire) to 0 V, or leave disconnected. Refer to installation instructions.
Flashing Red/ Green LED	Emitters need cleaning.	<ul style="list-style-type: none"> Power off product, clean emitters.
Poor Ionisation/ Neutralisation Performance	Emitters need cleaning.	<ul style="list-style-type: none"> Power off product, clean emitters.
	Emitters worn.	<ul style="list-style-type: none"> Check emitters for excessive wear.
	Ioniser installed too far from material to be neutralised.	<ul style="list-style-type: none"> Review installation, move ioniser closer to material if possible. Refer to installation instructions.
	Emitters too close to earthed metal surfaces.	<ul style="list-style-type: none"> Review installation, move ioniser further away from earthed metal surfaces if possible. Refer to installation instructions.

9. Accessories

A range of accessories to assist with installation and maintenance of the Ioniser is available from Fraser Anti-Static Techniques. Please contact your local distributor to enquire regarding pricing and delivery of these items.

Item Picture	Description	Part No.
	3 m cable M8 female, Bare ends. Straight socket.	80892
	5 m cable M8 female, Bare ends. Straight socket.	80930
	7.5 m cable M8 female, Bare ends. Straight socket.	80931
	10 m cable M8 female, Bare ends. Straight socket.	80932
	3 m cable M8 female, Bare ends. 90° socket.	80933
	5 m cable M8 female, Bare ends. 90° socket.	80934
	7.5 m cable M8 female, Bare ends. 90° socket.	80935
	10 m cable M8 female, Bare ends. 90° socket.	80936
	Universal AC-DC power supply: 100 - 250 V AC, 24 V DC output. Fitted with 1.5 m of cable.	E3024-PSU
	M8 male to M8 female 4-pin extension cable for AC-DC power supply unit. (Available in 2 m lengths).	80937
	Fraser Ioniser Cleaning kit containing: <ul style="list-style-type: none">• 500 ml of Cleaning Fluid.• Soft bristle hand brush.• Instructions for use.	81220

10. Appendix I: Technical Specification and Dimensions

Power Supply

Input Voltage:	24 V DC nominal, 21 - 28 V operating range 0 V earthed
Input Current:	0.25 A max
Maximum Input Power:	7 W
Input Connector:	M8, 4-pole, male

Output

Ionisation Method:	Pulsed DC
Output Voltage:	+/- 7 kV nominal
Output Frequency:	10 Hz as standard Other frequency on request from 1 - 50 Hz
Emitter Material:	Tungsten
Emitter Touch Current:	<100 μ A

Monitoring

LED Status Indication:	Flashing Green: OK, Ioniser operating normally Flashing Red / Green: Ioniser requires cleaning Constant Red: Supply voltage out of range or internal fault Flashing Red: Ioniser in STANDBY mode
-------------------------------	---

Remote Monitor Output

Signalling Output:	'ATTENTION' output signal on pin 4 (black wire)
Output Signalling Levels:	24 V output, 3 k Ω output impedance
Output Current:	Sourcing (+24 V): 8 mA Sinking (0 V): 20 mA Limited to 50 mA max (output low) by internal protection
PLC Compatibility:	Compatible with IEC 61131-2 Type 3 PLC inputs
Remote Monitor States:	+24 V: Ioniser OK 0 V: Ioniser requires cleaning, Ioniser fault, Ioniser in STANDBY mode

Remote Input

Signalling Input:	'STANDBY' input signal on pin 2 (white wire)
Input Signalling Levels:	0 V / 24 V nominal signal level (28 V max) <1 V or disconnected: Ioniser operates normally >21 V: Ioniser in STANDBY mode
Input Signalling Delay:	<1 s
Input Impedance:	5 k Ω nominal input impedance

10. Appendix I: Technical Specification and Dimensions

Protection

Internal Protection:	Under-/over-voltage indication, surge protection, reverse supply polarity protection HV supplies protected against internal overload and short-circuit Signalling output protected against short-circuit
-----------------------------	--

Environmental Conditions

Ambient Temperature:	0 – 55 °C
Relative Humidity:	Maximum 70 % rH, non-condensing
Ingress Protection:	IP67
Vibration:	Installation location must be vibration-free

Mechanical

Dimensions:	80 mm x 47 mm x 16 mm (excluding connector)
Mass:	100 g
Materials:	PVC body, epoxy resin encapsulant, tungsten emitter

Regulatory

CE Marking	EU LVD (2014/35/EU): EU EMCD (2014/30/EU): EN 61000-6-3:2007, EN 61000-6-2:2005
Approvals	UL Certified

10. Appendix I: Technical Specification and Dimensions

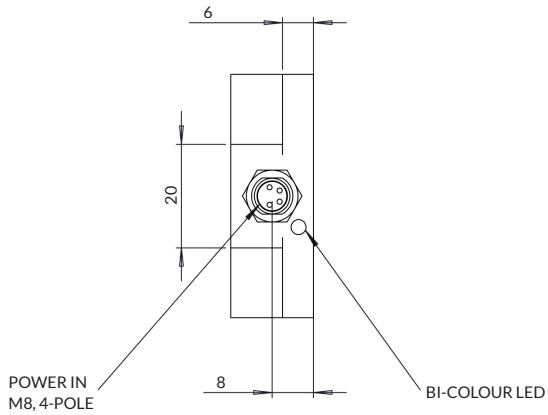
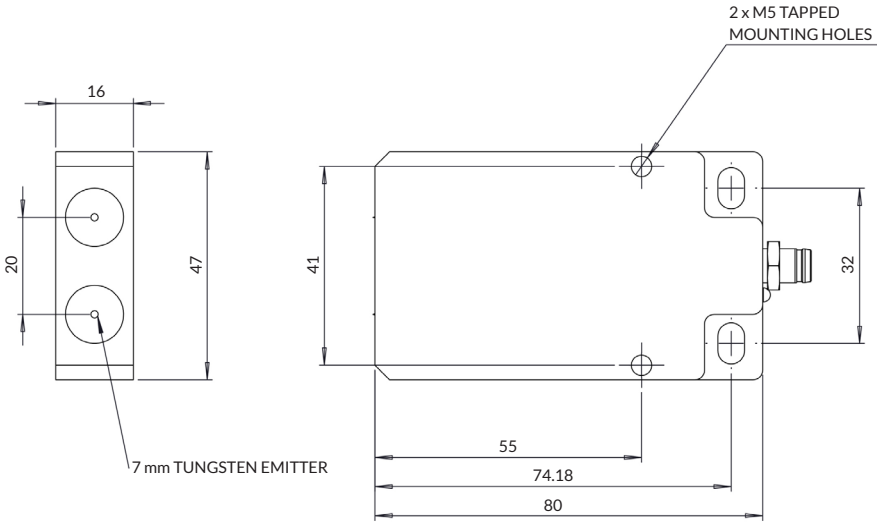

11. Appendix II: Remote Interface and Wiring Examples

This section describes the functioning of the remote monitoring interface in more detail and provides wiring examples for common installation types.

11.1. Remote Output Signalling Scheme

The remote monitoring interface has one output signal, **ATTENTION**. The signalling scheme is described in the following table:

Condition	Ionisation	ATTENTION (Black, Pin 4)
Ioniser powered, all OK	ACTIVE (HV ON)	ACTIVE (24 V)
Ioniser powered, requires attention (e.g. cleaning)	ACTIVE (HV ON)	INACTIVE (0 V) Will sink current
Overload, hardware fault, supply voltage out of range	INACTIVE (HV OFF)	INACTIVE (0 V) Will sink current
Ioniser in STANDBY	INACTIVE (HV OFF)	INACTIVE (0 V) Will sink current
Ioniser not powered	INACTIVE (HV OFF)	INACTIVE (0 V) Will not sink current

IMPORTANT:

Because the output is implemented using an electronic switch rather than a relay, when the ioniser is not powered, the output will **not** sink current.

11. Appendix II: Remote Interface and Wiring Examples

11.2. Remote Output Electrical Specifications

The **ATTENTION** signal is designed to allow direct connection to PLC digital inputs conforming with IEC 61131-2 Type 3 characteristics. The detailed specification of the remote signalling output is given in the table below.

Characteristic	Specification	Notes
High-level output voltage, open-circuit	$V_{IN} - 0.5 \text{ V}$	V_{IN} is nominally 24 V. High-level output voltage depends on power supply voltage.
Output impedance, high-level	3 k Ω	Internal pull-up to V_{IN}
Maximum output current, high-level, $V_{IN} = 24 \text{ V}$ (sourcing)	8 mA	Output shorted to 0 V
Low-level output voltage, open-circuit	0 V	Connected internally to 0 V by low-impedance switching device
Output impedance, low-level	<50 Ω	
Maximum output current, low-level (sinking)	20 mA	Protected by internal self-resetting fuse
Maximum externally applied voltage	28 V	Signal output is also protected against transient over-voltage

11.3. Remote Input Signalling Scheme

The remote interface has one input signal, STANDBY. The signalling scheme is described in the following table:

STANDBY (White, Pin 2)	Ionisation	LED
Low (<0.5 V)	ACTIVE (HV ON)	Flashing Green
	ACTIVE (HV ON)	Green / Red Flashing
	INACTIVE (HV OFF)	Constant Red
High (+21 V to +28 V)	INACTIVE (HV OFF)	Flashing Red

11. Appendix II: Remote Interface and Wiring Examples

11.4. Remote Input Electrical Specifications

The **STANDBY** input signal is designed to allow direct connection to a PLC digital output, a switch or a relay contact. The detailed specification of the remote signalling input is given in the table below:

Characteristic	Specification	Notes
Nominal drive voltage	0 V / 24 V	Digital input with 24 V logic-level
High-level threshold voltage	8 V typical 20 V maximum	A high-level drive voltage of at least 21 V is recommended
Low-level threshold voltage	6 V typical 1 V maximum	A low-level drive voltage of less than 0.5 V is recommended
Input impedance	5 k Ω +/- 10 %	Internal pull-down to 0 V
Maximum input current, input connected to +28 V	6 mA	Limited by internal resistor
Maximum externally applied voltage	28 V	Input is protected against transient over-voltage. However, prolonged exposure to voltages higher than 28 V may permanently damage the product.
Minimum externally applied voltage	-1 V	Drive voltages below 0 V are not recommended. Prolonged exposure to voltages lower than -1 V may permanently damage the product.

11. Appendix II: Remote Interface and Wiring Examples

11.5. Remote Interface Schematic

The simplified schematic diagram below shows the implementation of the remote signalling input and output on the Ioniser. This is a simplified model of the electronic interface within the Ioniser.

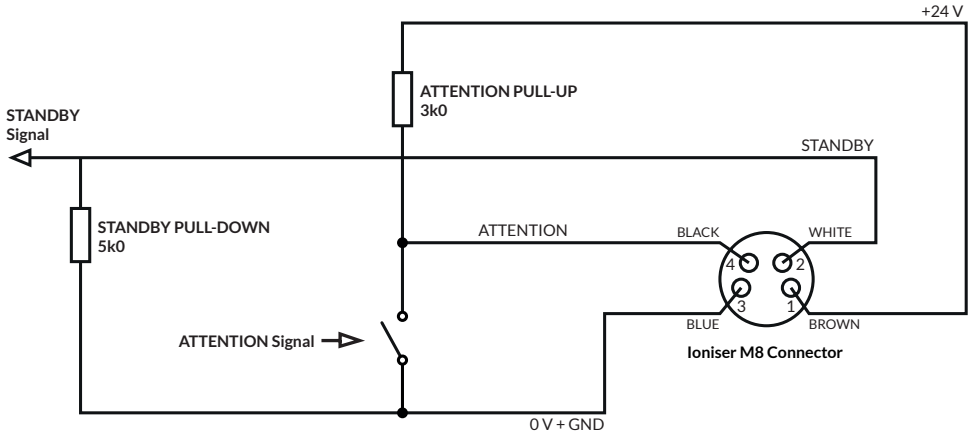

The switch in the diagram above is shown in the position corresponding to 'Ioniser powered, all OK'.

11. Appendix II: Remote Interface and Wiring Examples

11.6. Interfacing with PLC Systems

To interface the Ioniser with a PLC digital input conforming with IEC 61131-2 Type 3 characteristics, simply connect the 'ATTENTION' output from the Ioniser to the PLC digital input module as shown below. The 'STANDBY' line may be driven directly from a 24 V digital output.

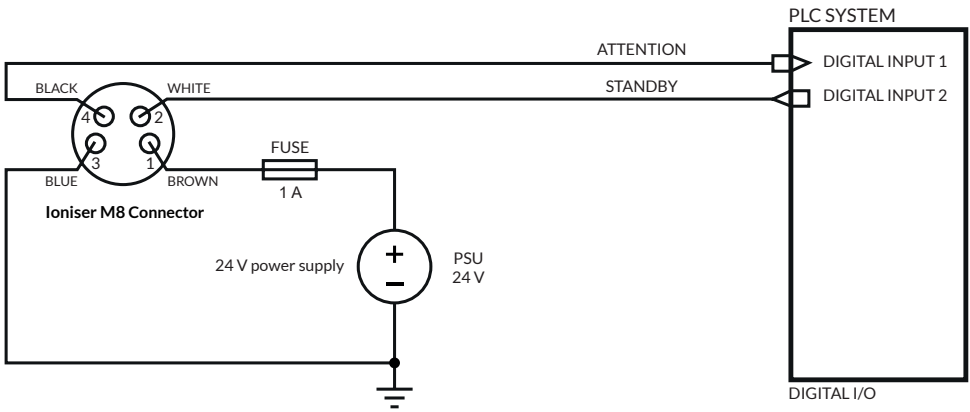

To interface the Ioniser with a PLC system having IEC 61131-2 Type 1 or Type 2 input characteristics, fit an external $1\text{ k}\Omega$ pull-up resistor to supply the current required by these input types, as shown below. The resistor should have a power rating of at least 1 W.

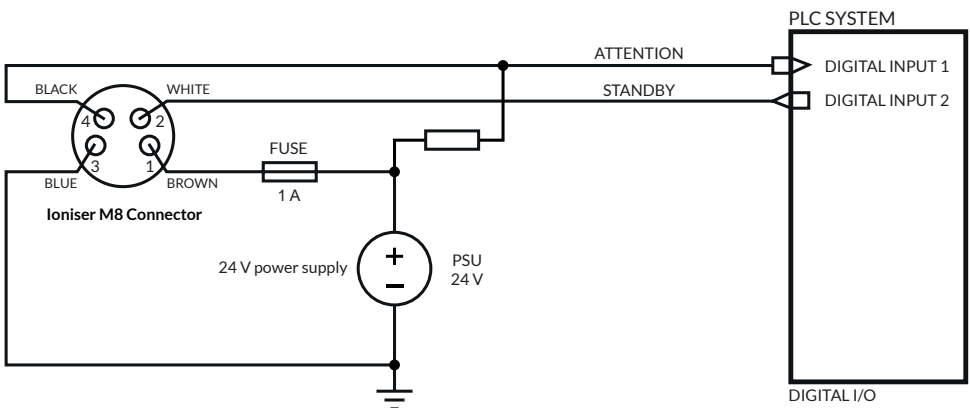

11. Appendix II: Remote Interface and Wiring Examples

11.7. Powering the Ioniser directly from a PLC digital output

A typical 24 V, 0.5 A, PLC output is capable of supplying the average current required by the Ioniser, and can be used to power the Ioniser directly.

It is possible that over-current trips may be experienced on PLC outputs due to the pulsing of the HV supplies in the Ioniser. This will depend on the characteristics of the PLC output module. In this case, use the PLC output to control a relay which switches the main 24 V supply to the Ioniser.

11.8. Connecting an external indicator to the ATTENTION output

Typical 24 V LED-based industrial indicators with rated current of 20 mA or less can be driven by the remote signalling output. The recommended wiring scheme for an external indicator is shown below. The indicator will illuminate when the Ioniser signals an 'ATTENTION' state.

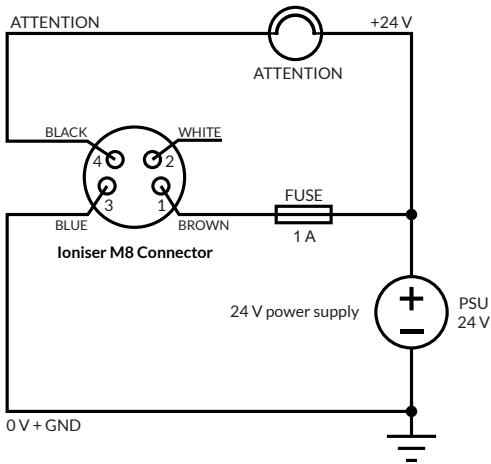

IMPORTANT: Connecting indicators with higher current requirements to the Ioniser will not damage it, but it is unlikely that satisfactory brightness will be obtained.



11. Appendix II: Remote Interface and Wiring Examples

11.9. Connecting an external relay to the ATTENTION output

To provide potential-free contacts or switch a higher voltage or current level, a relay can be installed between the loniser and external control circuit.

External relays must be connected with the loniser output **sinking** current to energise the relay coil.

PLC interfacing relays with high-sensitivity 24 V DC coils should be used to interface with the loniser. Some examples are:

- Phoenix Contact PLC-RSC series
- Wieland FLARE-24DC series
- Finder 38 series
- Omron G2RV series

IMPORTANT: Relay coil drive current at 24 V should not exceed 20 mA.

IMPORTANT: The external relay should be fitted with a coil suppressor.



The recommended wiring scheme for an external relay (using an SPCO relay) is shown below.

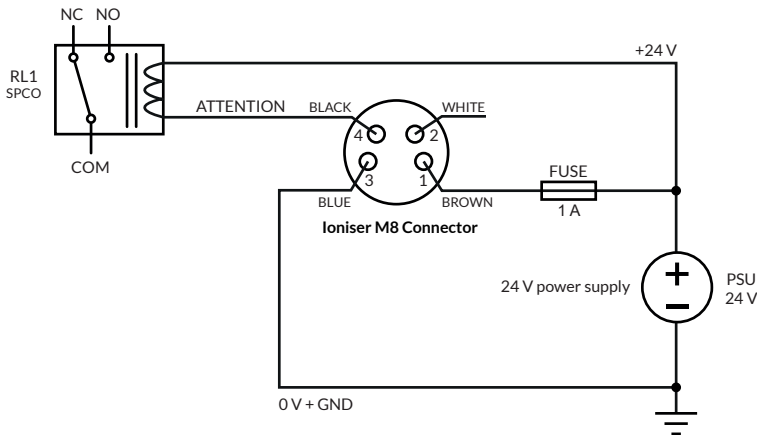

11. Appendix II: Remote Interface and Wiring Examples

11.10. Controlling the STANDBY line from a switch or relay contact

The recommended wiring scheme for controlling the Ioniser from an external switch or relay contact is shown below. When the switch or relay contact is closed, the Ioniser is in STANDBY mode. When the switch is open, the Ioniser is active.

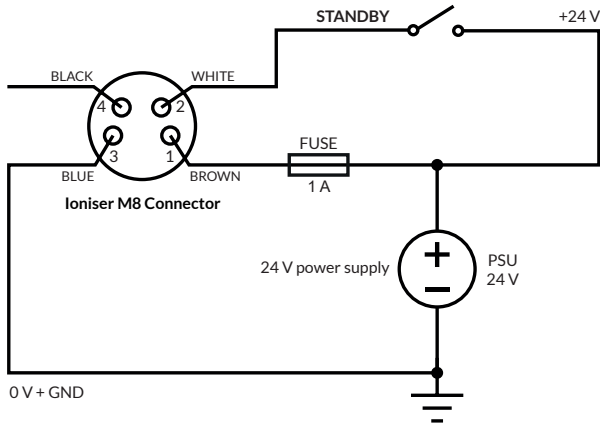

This Page Intentionally Blank

This Page Intentionally Blank

This Page Intentionally Blank

For more information about static and to view the full range of our products, please visit www.fraser-antistatic.com



Scotts Business Park, Bampton, Devon, EX16 9DN, UK
T + 44 (0) 1398 331114 F + 44 (0) 1398 331411
E sales@fraser-antistatic.co.uk W www.fraser-antistatic.com