



3024 Ionising Bar

From October 2013



Introduction	P2
What is New	P2-4
Overview	P5
Specification	P6
Performance	P7
Mechanical	P8
Electrical	P8
Operation/Control	P9
Dimensions	P10
Safety	P11
Ambient Conditions	P11
Installation	P12-13
Accessories/Spares	P14
Applications	P15-16

3024 - 24V DC Static Eliminators

The 3024 Static Eliminator Bar is a major new product for Fraser. It has built-in electronics and is powered by 24V DC. It is available in two versions:

Model 3024-F: (F = fast) for short range static neutralisation (25 - 100mm)

Model 3024-L: (L = longer range) for neutralisation at distances from 100mm to 500mm.



WHAT IS NEW ABOUT THE 3024?

Important Points which are the same for both Models

- Built-in electronics
- 24V DC supply.
- High performance.
- Compact size with overall length same as effective length.
- Remote monitoring.
- UL and CB Certified, for International use.

1) Built-In Electronics

Jupiter, which we launched in 2010, was the first static eliminator which we designed with built-in electronics. The 3024 advances this technology with integrated 9kV positive and negative generators making it suitable for short and medium range static neutralisation.

Conventional static eliminators which are powered by a transformer-based Power Unit, such as our 1250-S Bar, will continue to be suitable for multi-Bar applications, but for one Bar applications the new 3024 will provide strong competition.

Conventional Power Units are large, heavy and expensive. There are many advantages for having all of the electronics built into the Bar.

Notes

2) 24V DC Supply

The **3024** is powered by 24V DC. Most machinery manufacturers want equipment which operates on 24V DC. It is the standard voltage on many machines and often more readily available than 115V / 230V AC supplies.

24V DC makes the product more international - there is no need to worry about the voltage or frequency of the electrical supply.

Low voltage 24V power cable is much easier to use than traditional high voltage cable to the Bars. The connection to the Bar is with a standard 4 pin M8 connector. This is fast, safe and simple. There is a choice of external cable and connectors - please see page 14. These must be ordered in addition to the Bar. They are not included in the price of the Bar. They are offered at low net prices and are also available direct from Murr, Lumberg and similar suppliers.

3) High Performance

The **3024-F Bar** is designed to operate at a distance of 25-100mm from the material. The best distance is between 30 - 70mm. At this distance it is the most powerful short range static eliminator that we have ever tested. It is even more powerful than the 1250-S Bar and Super 80.

The 3024-F is about 95% more powerful than the 1250-S Bar.

The **3024-L** is the first medium range static eliminator Bar that we have designed so a comparison with an existing Bar is not possible. To give an idea of its performance at distances of 100-300mm it can be compared with a Model 2050 Ionised Air Blower - the same performance but without air movement.

See performance data on page 7.

4) Compact Size

The profile of the 3024 is small: 22mm x 41.5mm, but the main advantage regarding size is that the effective length of the 3024 Bar is the same as the overall length. This is unique for short range Bars in our industry .

We believe that this is extremely valuable to manufacturers of small machinery.



The emitters on the 3024-F begin 12mm from each end which produces ionisation along the whole length of the Bar.

There is no "dead-zone".

Notes

5) Remote Monitoring

The customer wants to know that the Bar is working. In some industries this is so important that they want a signal which stops the machine if the static eliminator is not functioning correctly.

The 3024 Bars show the operational status in two ways:

- i) The LED at the end of the Bar is a visual signal that the Bar is operational. It shows green if the function is good and red if there is no high voltage. The LED pulses with the frequency of the output – so the 3024L pulses at 5Hz and the 3024F pulses at 50Hz (which seems continuous).
- ii) From June 2013 there is an additional remote monitor which gives an electrical signal to show that the Bar is working correctly. A relay inside the Bar diverts some of the 24V DC input to send it back as a signal which the customer can use as he wants. See page 9 for full details.

6) UL and CB Certification

Meeting international safety standards is important and customers are not always happy to accept certification which has been made by the manufacturer. They want third party certification.

The international safety standard used for static eliminators is IEC60950, which is the unified standard for IT equipment.

We have had the 3024 Bar externally certified for UL and CB. UL certification covers USA and Canada; CB is the international product passport for industrial countries run by the IEC, see: <http://www.iecee.org/>.

It is unlikely that many of our competitors have this level of safety certification so is an important sales point, especially for machinery manufacturers.

Notes

THE 3024 STATIC ELIMINATOR BARS: OVERVIEW

A high technology static eliminator Bar with many customer benefits.

Available in two versions:

3024-F: for short range (25 - 100mm) and high speeds.

3024-L: for medium range (100mm - 500mm).

5) Protection of all components in a specially formulated epoxy resin, to give long life and IP66 protection.

4) Barrier between negative and positive emitters which prevents recombination of ions, increases performance and reduces maintenance.

3) Emitters in two rows - one side negative, the other side positive. Made in 99.975% tungsten, for a **very** long life.

2) Indicator LED
Shows operational status.
Green: OK,
Red: Fault.

1) 24V DC Supply
4 pin M8.

6) Effective length is same as overall length.

7) Mounting of Bar is designed to be fast and simple.

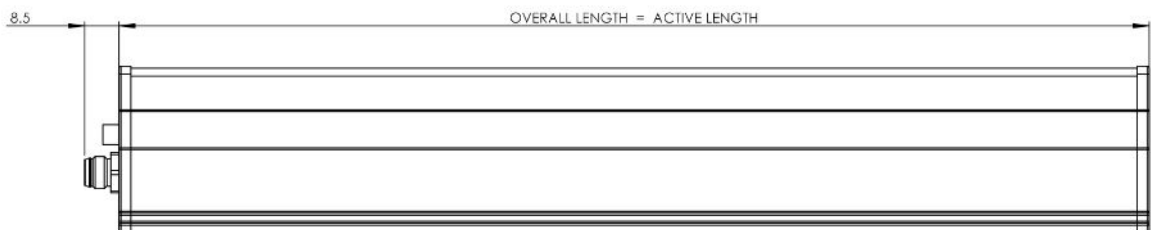
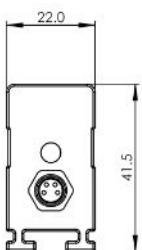
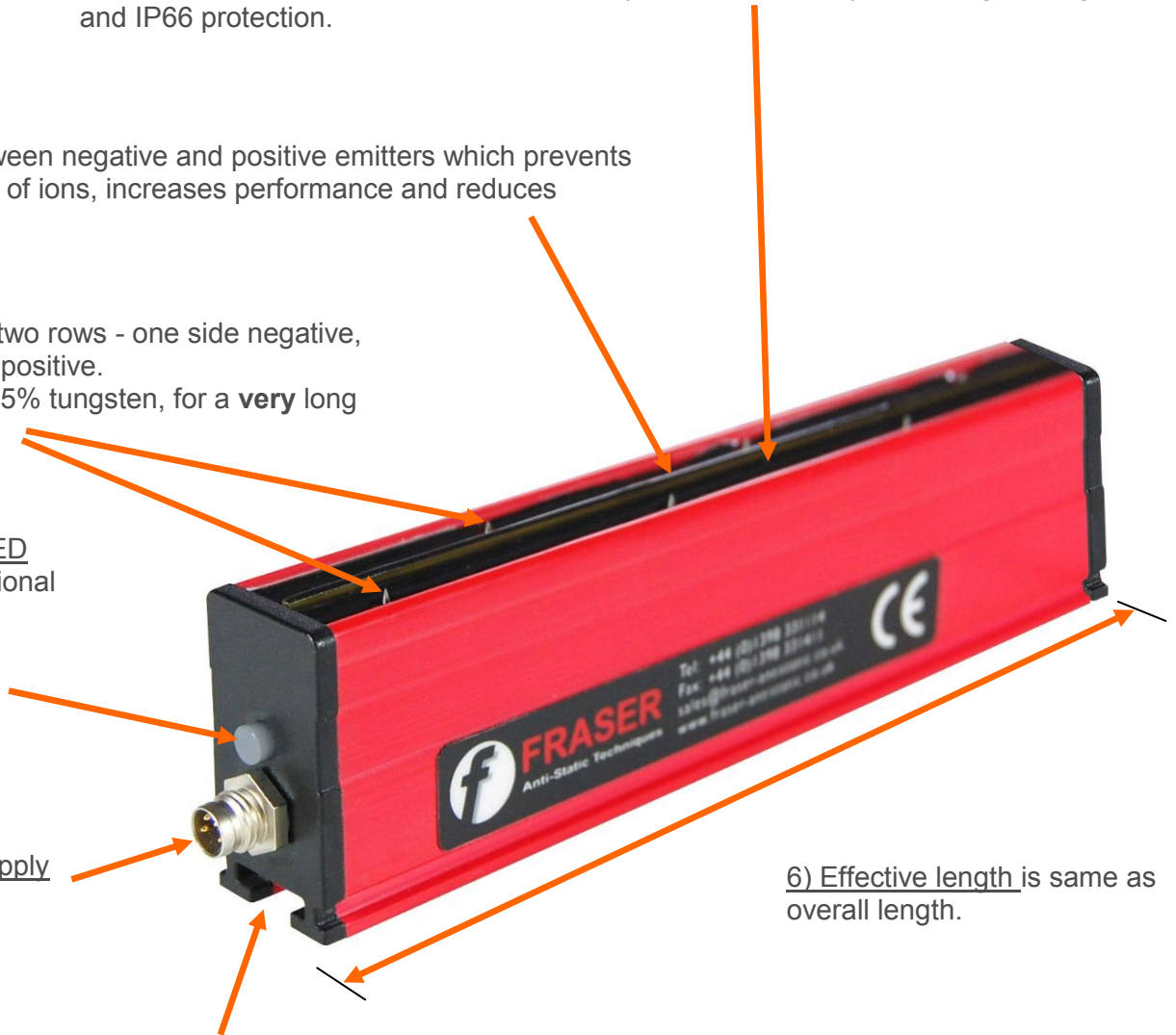

What is the difference between the 3024-F and 3024-L?

There are two differences:

- 1) The emitter pitch on the 3024-F is 25mm positive to negative; on the 3024-L it is 50mm. This is the only physical difference. This pitch dictates the sizes available - see below.
- 2) The programming of the electronics is different - the 3024-F is programmed to neutralise charge at a short distance using fast frequency square wave DC. The 3024-L is programmed to work at a longer range using ion propulsion as used in the Jupiter Bar. It uses square wave DC at a slower frequency. The indicator LED shows this in a fast flashing, while the 3024-F has a continuous green illumination.

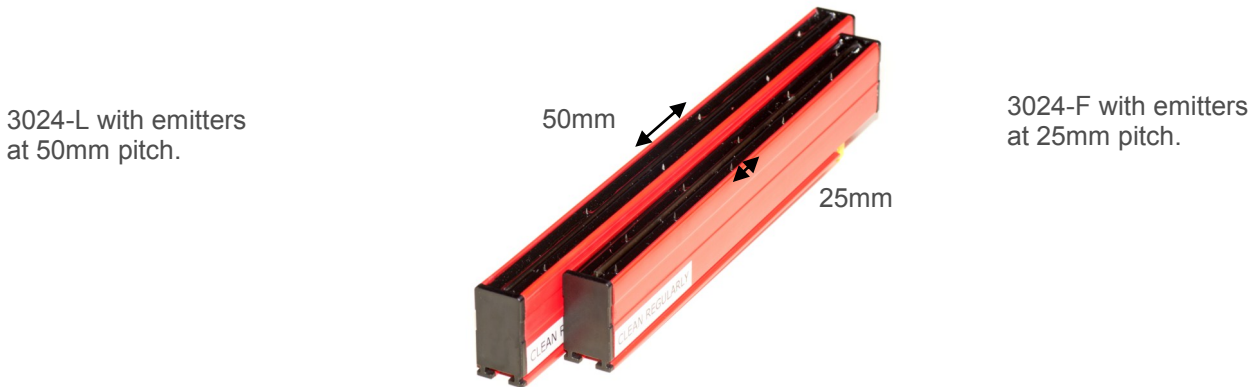

Summary Specification: 3024 Bars

Power Supply:	Voltage: 24V DC (21-28V). Current: 0.5A DC max without using the Remote Monitor. Up to: 1A DC using the Remote Monitor
High Voltage:	Up to 11kV integrated into Bar.
Supply cable:	Low voltage, industry standard M8 4 pin connector. Supply cables must be ordered in addition to the Bar. See spares/accessories on page 14.
Emitters:	Long life high grade tungsten 99.975% pure. Dedicated positive or negative. 3024-F: emitters at 25mm pitch, positive to negative. 3024-L: emitters at 50mm pitch, positive to negative. See photo above.
Status indication:	LED. Green = OK. Red = fault or dirty bar. Remote Monitor—see page 9.
Environmental:	IP66. Internal, industrial use. 0-55°C. Dry: max 70% rH, non condensing.
Length:	Effective length = 100% of overall length. 3024-F: Minimum length 250mm, then in 50mm steps. Max length 4.5m. 3024-L: Minimum length 300mm, then in 100mm steps. Max length 4.5m. The overall length is 6mm longer than the nominal length.
Height and Width:	Height = 41.5mm. Width = 22mm.
Weight:	1.1 kg/m.
Mounting:	Low profile mounting blocks within the slot in bottom of Bar.
Approvals:	CE, Low Voltage Directive, EMC Directive. C UL-US & CB.

3024-F

This Bar is designed for short range (25mm - 100mm) neutralisation and high speed applications. The performance measured on a Charge Plate Monitor - average time to discharge 1020pF (51 x the normal 20pF load) from 5kV to 500V:

Distance:	25mm	50mm	75mm	100mm
1250-S Bar	0.8 sec	2.5 sec	5.2 sec	12.9 sec
3024-F	0.4 sec	1.2 sec	3.3 sec	6.91 sec

These results show that the 3024-F is on average about 73% more powerful than the standard 1250-S Bar as measured on a Charge Plate Monitor.

The 3024-F was independently tested on a high speed test rig. With very high speed there are always questions about the accuracy of measurement - most static measuring instruments cannot react sufficiently quickly to very high speeds. However, while we cannot claim complete accuracy for the following figures they are valid as a comparison.

Distance of 50mm. Web charge level of approximately 50kV before ionisation. Charge after ionisation:

Speed:	100m/m	200m/m	500m/m	1000m/m	1500m/m	1800m/m
1250-S Bar	1.06kV	3.1kV	4.8kV	2.8kV	7.4kV	10.1kV
3024-F	0.12kV	0.3kV	1.03kV	0.34kV	2.5kV	3.4kV

The 3024-F Bar is the most powerful Short Range Bar that we have ever tested.

3024-L

The 3024-L is not comparable to the long range Ionstorm or Jupiter Bars. It must be seen as a medium range static eliminator operating at its best distances of 100mm to 300mm. It will neutralise charge at distances up to 500mm, especially if the charge level is high, but it will not be as powerful as Ionstorm or Jupiter at these distances.

This fills a big hole in our product range - we have never had a true Medium Range Bar.

The easiest way of showing its performance is by comparing it with a 2050 Blower on a large Charge Plate Monitor. The 2050 has better performance than any blower that we have tested, so is a good comparison.

Time to decay from 5000V to 500V charge on a large (88pF) charge plate. Average of (+) and (-) times.

	2050 Blower	3024L 300mm
<u>100mm</u>	0.4 sec	0.21 sec
<u>200mm</u>	0.75 sec	0.52 sec
<u>300mm</u>	0.9 sec	0.8 sec

This is excellent performance - the 3024L performance will be even better if the problem charge is more than 5kV. If the charge is, say 20kV, the 3024-L will easily outperform the Blower.

Construction, Body and Mechanical Parts

The extruded body is made from a UL grade flame resistant ABS. The black endcaps are a similar FR-ABS injection moulding grade.

The electronics are encapsulated in epoxy resin for protection and to give the product the ability to withstand tough treatment. The epoxy is a specially formulated resin which is resistant to ozone and UV light, both of which are produced by all ionising emitters.

Emitters are made from pure tungsten which will give many years of high performance ionisation.

The water and dust protection level is IP65.

The weight of the 3024 is 1.1kg per m.

The minimum and maximum sizes of the 3024 Bars are determined by the length of the electronics and the emitter pitch - please see page 6. The maximum length of both models is 5m in 50mm steps from 250mm (3024F) or in 100mm steps from 300mm (3024F).

Electrical

The electrical supply is 24V DC. (20V - 28V max.) Maximum current 0.5A.

The connector is a 4 pin M8 Connector. The male connector is on the Bar.

The cable with female connector is not supplied with each Bar. It must be ordered separately. See options and part numbers on page 12.

If 24V DC is not available the customer can order a Power Supply to convert the mains voltage to 24V DC. Model E3024-PSU - See Page 14.

Important

This Power Supply has a double earthing, other power supplies without a double earthing cannot be used.

Wiring:

Reverse polarity protected.

M8 4 pin male connector for 24V DC

Male Pins on Bar, Female on Cable



Notes

MALE

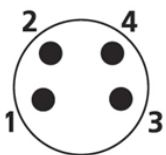

FEMALE

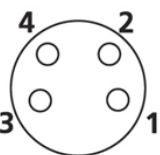

Pin	Colour	Function
1	Brown	24V
2	White	Earth / Ground
3	Blue	0V
4	Black	Remote Monitor

In addition to the LED on the Bar, from May 2013 there is also a remote monitoring signal available from the Bar to show the operational status of the high voltage.

The schematic below shows the wiring arrangement and two possible ways of using the signal - powering a small lamp or for triggering a relay in the machine's PLC.

Operation and Control

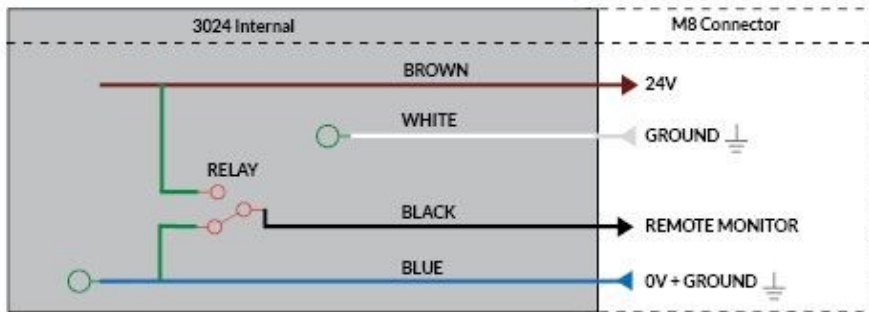

Remote Monitor signal is valid 4 seconds after power is applied.

BLACK = 24V when 3024 status signal **OK**
BLACK = 0V when 3024 status is **FAULT**

Example Application Use Of Remote Monitor

EXTERNAL LAMP/INDICATOR

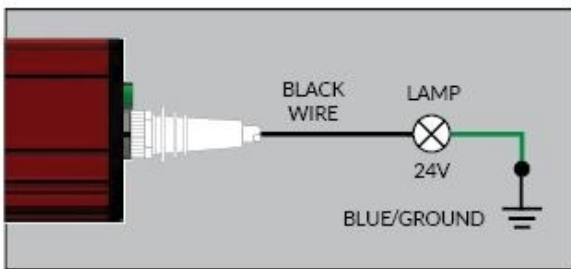

External indicator can be connected to BLACK wire to show status. This is useful for bars mounted in inaccessible areas.

Lamp rating 24V DC, maximum 10W. A LED can also be used with a suitable resistor. Maximum current 0.5A.

EXTERNAL RELAY

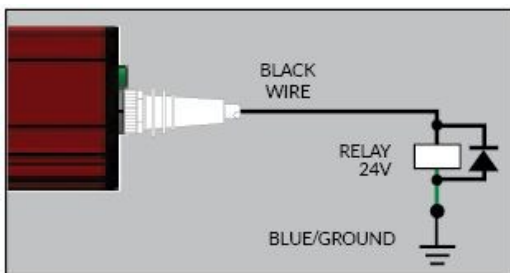

External replay can be connected for additional control/feedback configurations.

Coil rating 24V DC, 10W max.

Dimensions

Notes

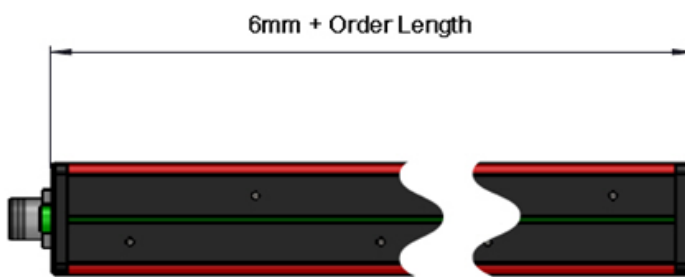
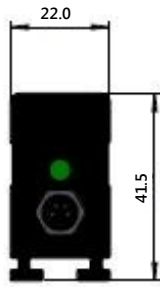

180° Connector

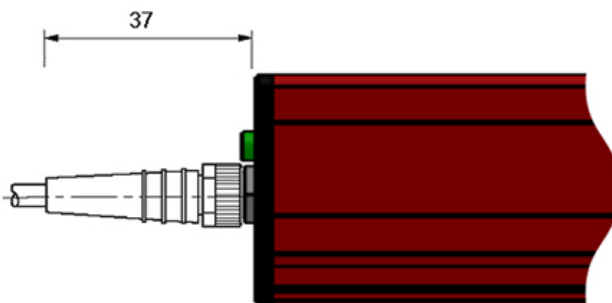

90° Connector

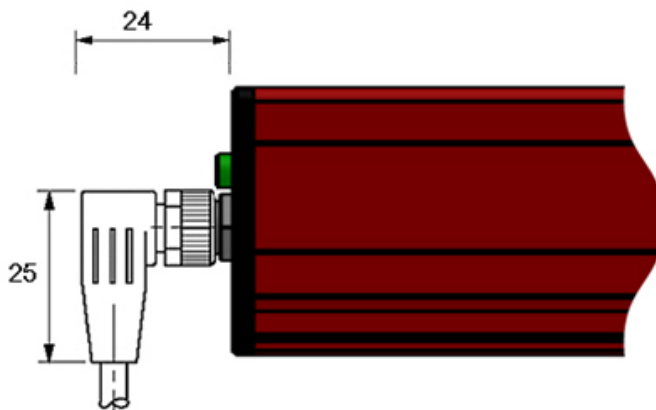

Safety

The emitter pins are resistively coupled to the high voltage supply. Each emitter pin has a dedicated 100M Ω resistor rated at over 15kV. This means that the emitter pins are shockless to touch. The current at the pin is approximately 90 μ A.

Note: that if the emitters are connected in parallel, for example by high levels of moisture after washing, then the resistance will be reduced and so the energy level on the emitter pins will be increased. This applies to all resistively coupled static eliminators, not just the 3024. Ensure that the Bar is dry before turning on power.

The negative and positive voltages are not “ON” at the same time.

There is input power limitation.

There is full voltage regulation and overload protection in the electronic circuitry.

The emitter pins are sharp - care is required when handling and cleaning them.

Ozone: all high voltage equipment produces ozone. The ozone emission from 3024 Bars is less than 0.1 ppm and meets international standards.

Operational Conditions

Class: Indoor, industrial use.

Temperature: 0°C to 55°C maximum.

Humidity: Maximum 70% rH, non-condensing.

Cleaning: The 3024 should be kept clean for optimal performance. A layer of dirt will allow current to flow to earth instead of being used to produce ionisation. Physical impurities on the emitter pins will work against ionisation.

Dust can be removed with a nylon (or other plastic) brush - such as a toothbrush. Stubborn dirt may be removed by a solvent, such as IPA, or other cleaning liquid which is compatible with ABS and epoxy resin.

The IP65 construction of the 3024 allows liquids to be used in cleaning the Bars and allows the Bars to be used in food and similar applications where there are “wash-down” procedures. In these cases it is important that the power to the Bar is switched OFF before cleaning or maintenance work and that the Bar is dry before switching power ON.

Where washing is required it is important that the Bar is positioned so that water cannot collect around the emitter pins - they should face downwards.

As mentioned above, if water is present around the emitter pins the Bar will no longer be shockless as the current limiting resistors be low each pin will be connected in parallel and so have a lower resistance.

Notes

Installation

3024-F

- Distance from material: 25 -100mm. Do not position the 3024-F closer than 25mm to the material.
- Material should be in free air, as with a normal 1250-S Bar installation, for the best performance
- With a plastic DC Bar like the 3024-F the nearest earth should be more than the distance of the product. If there is an earthed body closer to the Bar than the material to be neutralised it will attract the ions from the Bar. So if the Bar is 50mm from the material to be neutralised there should be no metal and earthed parts closer than this.

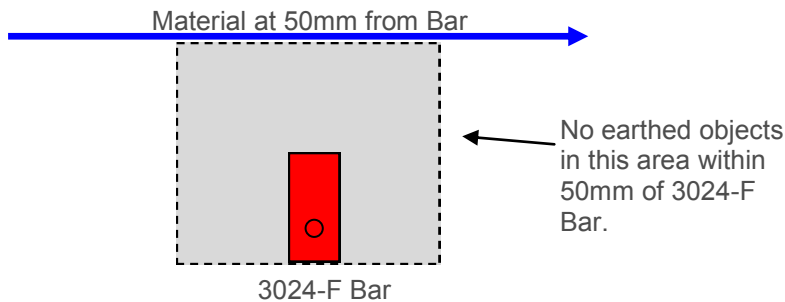

3024-L

- Distance from material: 100 to 500mm. Best distance 100 - 300mm. Do not position the 3024-L closer than 100mm to the material.
- General installation considerations are the same as Jupiter or Ionstorm.

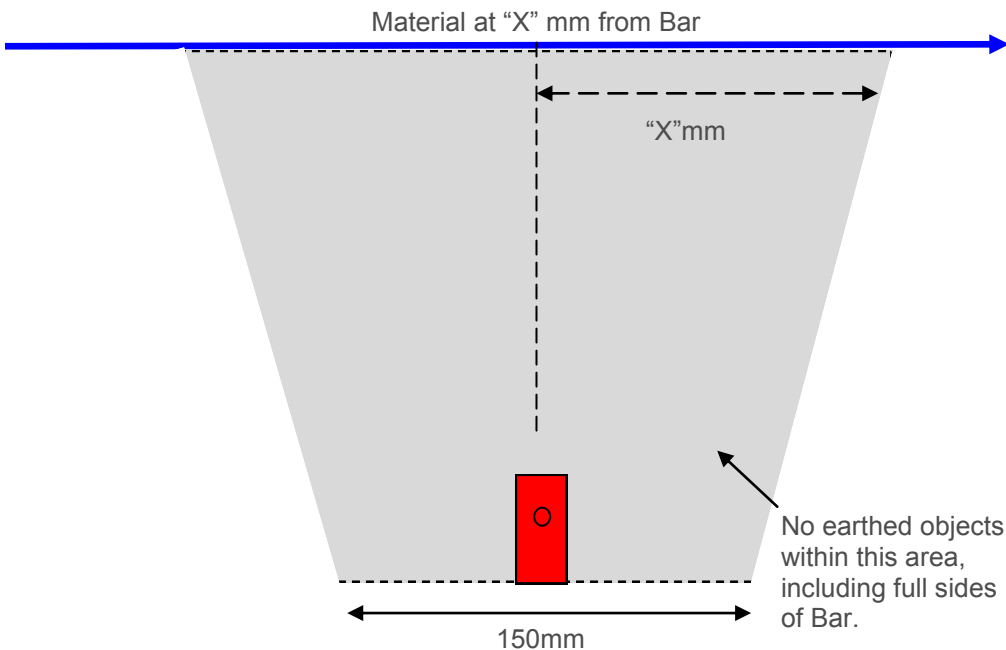

Notes

Installation Cont.

Versatile 'T' brackets slide into slot at the bottom of the bar.

M6 x 40mm long studs. Two mounting 'T' pieces for bars up to 1m, then an extra 'T' piece for every additional 500mm.

Other stud lengths are available, contact the factory for options.

Bars over 1m long should be supported in the middle in addition to at each end. Bars over 2m should have two middle supports in addition to the end supports.

In the unlikely case that two Bars are required, one on each side of a material, they should be offset by at least 50mm.

Distance "B" should be at least 50mm.

This is the same as with a 1250-S Bar.

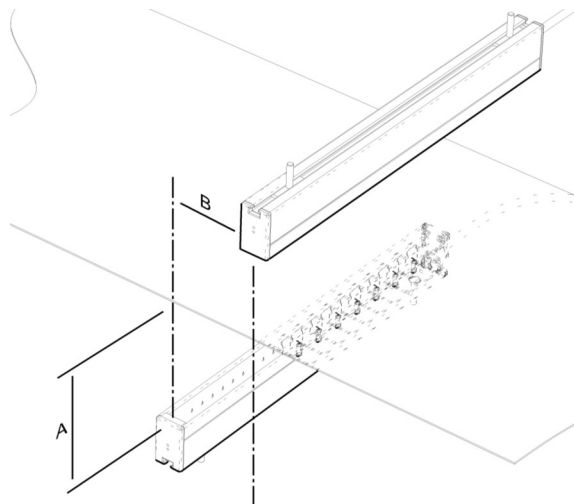
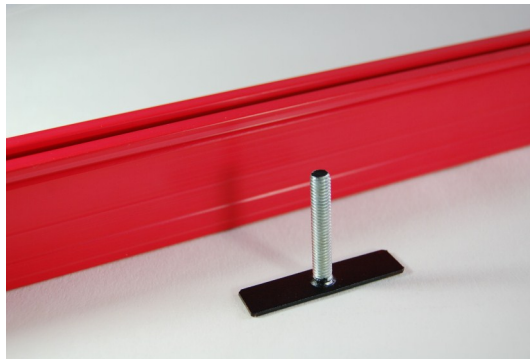

Notes

Accessories and Spare Parts

The M8 x 4 wire power cables are not included in the price of the 3024 Bar. They are an accessory which we supply at a low net price. They are standard DIN M8 x 4 wire cable and connectors which are also readily available from Murr, Lumberg etc.

Item Picture	Description	Part Number
	3m cable M8 female, bare ends. Straight socket.	80892
	5m cable M8 female, bare ends. Straight socket.	80930
	7.5m cable M8 female, bare ends. Straight socket.	80931
	10m cable M8 female, bare ends. Straight socket.	80932
	3m cable M8 female, bare ends. 90° socket.	80933
	5m cable M8 female, bare ends. 90° socket.	80934
	7.5m cable M8 female, bare ends. 90° socket.	80935
	10m cable M8 female, bare ends. 90° socket.	80936
	Universal AC/DC power supply: 100-250V AC, 24V DC output Fitted with 1.8m of cable IEC 320 socket.	E3024-PSU
	M8 male to M8 female 4-pin extension cable for AC/DC power supply unit. (available in 2m lengths).	80937
	Mounting 'T' Bracket and flanged nut.	30248

Applications

The applications for the 3024-F are the same as for the 1250-S Bar:

Plastic Film and Sheet including:

Extrusion	Converting	Tape Lines
Printers	Centre Winders	Sheet cutters
Laminators	Perforators	Embossing
Bagmakers	Signs	

Plastic Mouldings including:

Blow Moulding	Thermo & Vacuum Form	Injection moulding
---------------	----------------------	--------------------

Packaging, Food etc including:

Stretch wrapping	Closures,	Plastic Bottles
Canning	Conveying	Wrappers,
Overwrappers	Checkweighers	Ink jet
Shrink sleeve	Tamper Evident	Label application
Cigarettes	Drying	Vertical Form Fill Seal

Paper and Printing

Digital Printing	Paper Mills	Converting
Paper Products	Tissue	Paper Folders
Wallpaper presses	Screen Printing	Pad Printing
Flexo Presses	Gravure presses	Forms Presses
Label Presses	Sheet and Web Presses	

Textile

Carding	Beaming	Warping
Sizing	Stenters	Finishing
Inspection Machines	Transfer Printing	Non-wovens
Technical Fabrics	Creels	Lace machines
Narrow fabrics		

General Industry

Conveyors	Pneumatic transport and handling

Applications for the 3024-L are similar to Ionstorm - but with a shorter range. Typically winders on smaller machines.

There is a selection of application photos on the next page.

Notes

3024L Bars on Winders

