



---

**8001 PRECISION POINT IONISER**  
ESD IONISATION





Fraser static control equipment has been designed to give you many years of productive service. However, the science of static control has unique rules which must be followed to allow the equipment to give a good return on your investment.



Please read the following operating and maintenance instructions carefully.

<b>Contents</b>	<b>Page</b>
1 Introduction	4
2 Safety	5
3 Air Supply	6
4 Checking on Delivered Equipment	7
5 Mechanical Installation	8
6 Electrical Connections	11
7 Monitoring: Status LEDs and Remote	13
8 Commissioning and Operation	14
9 Maintenance	15
10 Troubleshooting	16
11 Remote Interface and Wiring Examples	17
12 Technical Specification	23
13 Spare Parts and Accessories	25

---

## 1. Introduction

---

This manual applies to the Fraser 8001 Precision Point Ioniser, supplied from Fraser Anti-Static Techniques. These products are used by leading manufacturers throughout the world to increase safety and productivity.

It is essential that you read and understand the complete manual before installing and using this equipment. This is important for safety and warranty cover.

### 1.1. Explanation of Symbols

#### Warning!

This symbol appearing in the operating instructions refers to operations which, if carried out improperly, may result in serious personal injuries.



#### Caution!

This symbol appearing in the operating instructions refers to operations which, if carried out improperly, may result in damage to property.



#### Information!

This symbol refers to information which relates to obtaining the best performance and operating life from the product.



### 1.2. Features and Benefits

The Fraser 8001 Precision Point Ioniser is designed to neutralise and clean electrostatically charged surfaces and small products using ionised compressed air.

The use of High Frequency AC provides excellent offset voltage, typically within  $\pm 20$  V when measured in accordance with ANSI ESD STM 3.1.

Powered by 24 V DC, it features an integrated high voltage supply meaning that no high voltage cabling is required.

The status of the 8001 Precision Point Ioniser, including need for cleaning, is indicated by three LEDs. Duplicate outputs enable integration with a control system/PLC.

The 24 V DC power supply and remote monitoring connections are made via an M8 4-pin connector. An external AC-DC PSU can be ordered if 24 V DC is not available.

Mounting onto the machine is achieved with two fixing holes integrated into the product body.

The 8001 Precision Point Ioniser is intended for use in indoor factory environments only. It is not suitable for outdoor use.

---

## 2. Safety

---

The Fraser 8001 Precision Point Ioniser has been designed in accordance with the safety requirements of the EU Low Voltage Directive.

- The product should be cleaned regularly. The product **must not** be disassembled or cleaned while powered, or while the air supply is pressurised.
- The emitter pin is a **Class 1** electrical energy source. It is inaccessible during normal operation. Direct contact with the emitter while the product is powered will not result in electrically-caused injury, but may cause a detectable pain sensation.
- The emitter pin is necessarily sharp. The emitter pin is a **Class 2** mechanical energy source. Contact with the emitter during cleaning may be painful, but will not cause an injury requiring emergency medical attention.
- Installation and maintenance must only be carried out by suitably qualified personnel.
- The negative pole of the 24 V DC supply provided to the product should be permanently earthed. A secondary earth connection must be made to the earthing terminal on the product body.
- Adequate installation earth/ground is required to ensure safe and proper operation.
- Do not connect or disconnect the M8 cable from the ioniser while it is powered.
- The metal parts of the nozzle are connected inside the product to the 0 V and GND terminal. Do not connect it to objects with a different electrical potential such as the conductive parts of external devices.
- A small amount of ozone will be produced as part of the ionisation process. When installed correctly the level of concentration of ozone is less than 0.1 ppm and is within internationally accepted limits.



Any changes to the equipment without written consent of the manufacturer will nullify the warranty and CE certification.

---

### 3. Air Supply

---

- The supply of compressed air must be clean, dry air.
- The supplied air pressure must not exceed 5 Bar.
- Optimal ion balance performance is obtained at an air pressure of between 0.5 Bar and 2 Bar.
- The product should not be run for prolonged periods without an air supply.
- The supplied air should not contain particulates, gases other than air, or corrosive substances.

---

## 4. Checking on Delivered Equipment

---

Before starting the installation please check that the 8001 Precision Point Ioniser has not been damaged in transit. If the packaging material is damaged, please report this immediately to the vendor.

Check that the additional items are present with the ioniser:

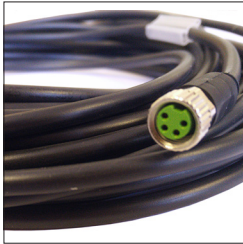

### Power Supply Cable

If ordered, a 24 V power supply cable with an M8 x 4-pin connector will be supplied.

See Section 13 for details of cables and other accessories.



### AC-DC Power Supply Unit

If ordered, a 24 V DC output, 100 - 250 V AC input PSU (Part No. E3024-PSU) will be supplied. The 0 V output is earthed and a secondary safety earth connection is provided.

**IMPORTANT:** DO NOT USE standard 'computer style' PSUs without earthed outputs to avoid risk of operator shocks, and damage to the PSU or ioniser.

---

## 5. Mechanical Installation

---

The body of the 8001 has 2 x 4.2 mm mounting holes. Use these mounting holes to attach the 8001 to your process or machinery.

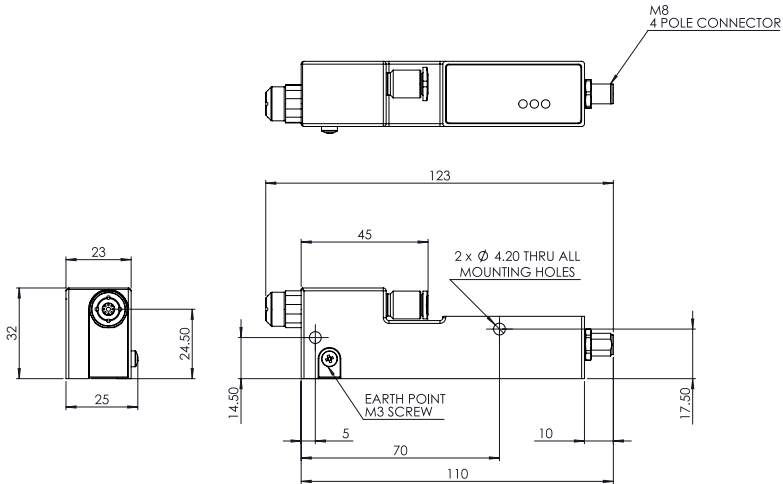

### 5.1. Nozzle Options

The 8001 is fitted as standard with the ESD single point nozzle. Depending on application, you can fit an alternative nozzle. A range is available, see Section 13 - Spare Parts and Accessories.

#### a. Ion Shower Nozzle

A straight, rigid nozzle with holes at 10 mm pitch.

Ionisation Pattern:

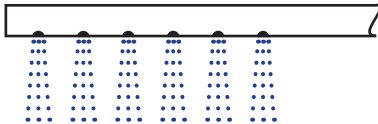

---

## 5. Mechanical Installation

---

b. **Fixed Precision Nozzle**

A straight rigid nozzle.

Ionisation Pattern:

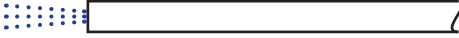

c. **Flexible Shape Preserving Nozzle**

A flexible nozzle that can be easily bent then holds its shape to give access to hard-to-reach areas.

Minimum bend radius of 40 mm.

Ionisation Pattern:



d. **Conductive Flexible Tube Nozzle**

A flexible nozzle that can be bent to give access to hard-to-reach areas.

Minimum bend radius of 15 mm.

500 mm long but can be cut to the required length.

Ionisation Pattern:



e. **Flexible Nozzle Extension**

A flexible extension piece that can add up to 500 mm between the body of the 8001 and the selected nozzle.

Minimum bend radius of 15 mm.

500 mm long but can be cut to the required length.

---

## 5. Mechanical Installation

---

### 5.2. Fitting

#### **To remove a nozzle**

Use a suitable sized spanner to turn the nozzle anti-clockwise. An O-ring seals the nozzle to the body of the 8001. Great force is not required to loosen the nozzle. When you remove the nozzle, make sure the emitter assembly remains in position in the body of the 8001.

#### **To fit a nozzle**

Use your fingers to initially fit the nozzle to the body of the 8001 - turn the nozzle clockwise. Use a spanner to make sure the fitting is tight. An O-ring seals the nozzle to the body of the 8001. Great force is not required to tighten the nozzle.

Use at least one 47013 nozzle holder assembly to support long or flexible nozzles.

#### **Adjustment of the Ion Shower Nozzle**

When fitted, the holes in the ion shower nozzle may not point in the correct direction.

To adjust the ion shower nozzle, loosen but do not remove the nut, rotate the nozzle to the correct position and carefully tighten the nut.

---

## 6. Electrical Connections

---

### 6.1. M8 Pin Assignments

The M8 connector pin numbering scheme is shown below.

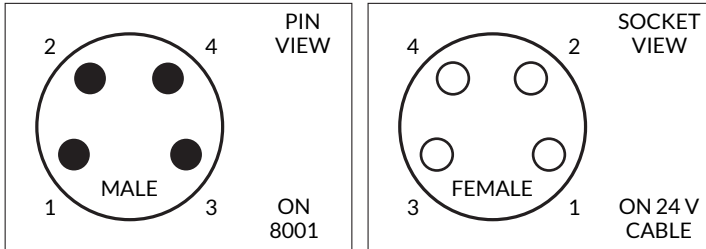

The pin assignment and typical wire colours are given in the table below. This refers to cables supplied by Fraser. Other cables may have different colour schemes.

Pin	Wire Colour	Function	Details
1	Brown	+24 V	21 – 28 V operating range, 0.1 A maximum current.
2	White	OK Signal	+24 V nominal output voltage, 3 k $\Omega$ output impedance in active state. Low impedance connection to 0 V in inactive state. See Section 11 for details.
3	Blue	0 V and GND	0 V must be connected to ground.
4	Black	ATTENTION signal	+24 V nominal output voltage, 3 k $\Omega$ output impedance in active state. Low impedance connection to 0 V in inactive state. See Section 11 for details.

---

## 6. Electrical Connections

---

### 6.2. Power Supply Connections

The diagram below shows the power supply connection required when using an existing 24 V DC supply.

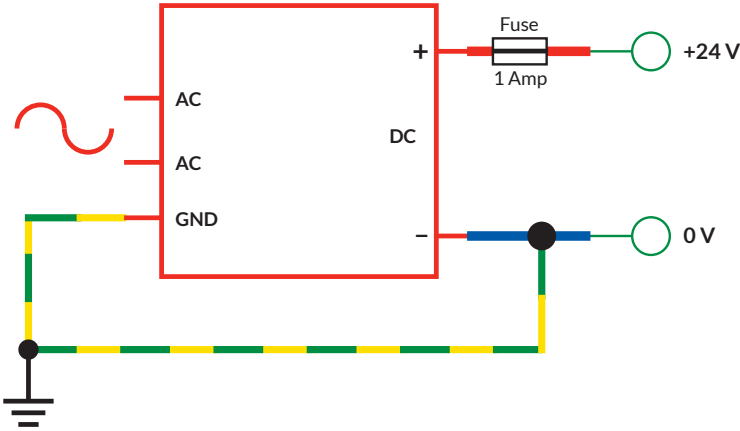

The 24 V supply connection (Pin 1, brown wire) must be fitted with a 1 A fuse. It is recommended that a type 'T' or 'gG' fuse is used.

The 0 V supply connection should be earthed. This connection should be made at the power supply output terminal if possible.

The earthing terminal on the product **must** be connected to the installation protective earth (PE).

**CAUTION:** If the product is not earthed the residual ion balance of the product cannot be guaranteed.

**WARNING:** If the product is not properly earthed, there is a risk of the operator receiving an electric shock from the product.



### 6.3. Functional Earth Connection

If needed, a functional earth can be fitted to the M3 screw on the side of the 8001.

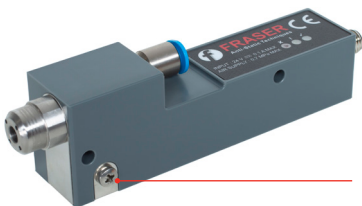





M3 screw for functional earth connection

---

## 7. Monitoring: Status LEDs and Remote

---

The LEDs on the ioniser indicate its status as follows:

LED Indication	Bar Status	Ionisation
Green 	OK	Active
Yellow and Green 	Cleaning/attention required	Active
Red 	Overload, over-temperature, hardware fault, supply voltage out of range	Inactive
Not Illuminated 	Ioniser not powered	Inactive

The Ioniser is equipped with a remote monitoring interface which allows the operating status of the product to be fed into a PLC system or checked remotely.

See Section 11 for wiring instructions and examples for the remote monitoring interface.

**Read these instructions carefully before installing the 8001. The electrical specifications and signalling scheme of the remote monitoring interface are different from those of other Fraser 24 V static elimination products.**

---

## 8. Commissioning and Operation

---

Before you turn on the 8001 for the first time, check the following:

- The positioning and mounting of the ioniser is in accordance with the instructions given in Section 5 of this document.
- The electrical installation of the ioniser has been completed in accordance with the instructions given in Section 6 of this document. Where needed, make sure the functional earth on the side of the 8001 is connected to ground.
- If using the external AC-DC power adapter, ensure that the supplementary grounding wire is connected to the installation protective earth.
- The compressed air is connected and at the correct pressure:  
0.5 - 2.0 Bar optimal, 5 Bar max.
- Any operators who will work in close proximity to the ioniser are aware of its presence and familiar with its operation.



---

## 9. Maintenance

---

**WARNING:** Always disconnect power before working on the ioniser



Cleaning is the only maintenance required. Dirt around the emitter will reduce ionisation effectiveness and result in unsatisfactory static neutralisation performance.

The frequency of cleaning will depend on the process and the environment in which the ioniser is installed. The ioniser should be cleaned when 'attention required' is indicated by the yellow LED and/or remote monitoring interface, or after approximately 1 week of continuous operation.

To ensure best performance, the ioniser nozzle should be visually inspected on a regular basis and cleaned whenever convenient.

A toothbrush or soft nailbrush can be used to clean the ioniser needle and plastic air splitter (the emitter assembly). Do not use a wire brush as this will damage the product.

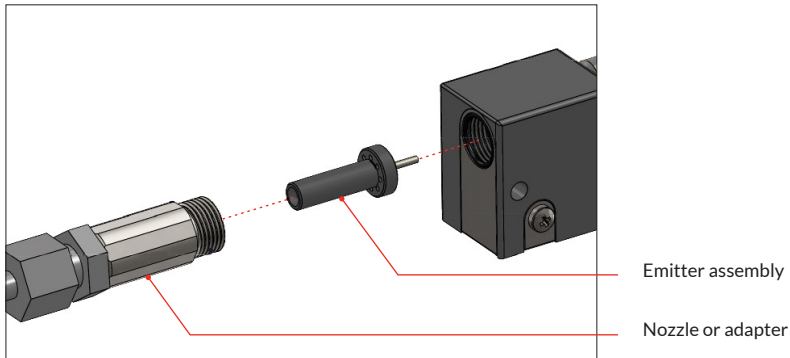

Suitable cleaning materials are warm soapy water or isopropyl alcohol (IPA).

The product must be dry before the power is switched back on.

For optimal cleaning results, use the Fraser Ioniser Cleaning Kit (Part No. 81220).



## 10. Troubleshooting

In the event of problems with the product, please use the following checks:

Symptom	Cause(s)	Solution(s)
No LED ○○○	Product not powered	<ul style="list-style-type: none"> <li>• Check power supply and connections</li> <li>• Check external fuse</li> <li>• Check supply cable for damage</li> </ul>
Red LED ●○○	Power supply voltage outside of specified range	<ul style="list-style-type: none"> <li>• Check and adjust power supply voltage</li> <li>• Ensure appropriate power supply cable used</li> <li>• Ensure power supply not overloaded</li> </ul>
	HV supply overloaded	<ul style="list-style-type: none"> <li>• Check nozzle for damage</li> <li>• Check emitter pin for damage</li> <li>• Check that there are no foreign objects inside the nozzle</li> </ul>
	Over-temperature	<ul style="list-style-type: none"> <li>• Move product to a cooler location</li> </ul>
	Internal fault	<ul style="list-style-type: none"> <li>• Contact supplier</li> </ul>
Yellow and Green LED ○●●	Emitter needs cleaning	<ul style="list-style-type: none"> <li>• Power off product, clean emitter and nozzle</li> </ul>
	Air pressure excessive	<ul style="list-style-type: none"> <li>• Reduce air supply pressure</li> </ul>
	Air contaminated	<ul style="list-style-type: none"> <li>• Use clean, dry oil-free air supply</li> </ul>
Poor Ionisation / Neutralisation Performance	Emitter needs cleaning	<ul style="list-style-type: none"> <li>• Clean emitter and nozzle</li> <li>• Check that there are no foreign objects inside the nozzle</li> </ul>
	Emitter worn	<ul style="list-style-type: none"> <li>• Check emitter for excessive wear</li> <li>• Replace the emitter, see Section 9 - Maintenance</li> </ul>
	Installed too far from material to be neutralised	<ul style="list-style-type: none"> <li>• Review installation, move product closer to material if possible</li> </ul>

---

## 11. Remote Interface and Wiring Examples

---

This section describes the functioning of the remote monitoring interface in more detail and provides wiring examples for common installation types.

### 11.1. Remote Signalling Scheme

The remote monitoring interface has two output signals, **OK** and **ATTENTION**. The signalling scheme is described in the following table:

Status LED	Condition	Ionisation	OK (White, Pin 2)	ATTENTION (Black, Pin 4)
Green ○ ○ ●	Ioniser powered, all OK	ACTIVE (HV ON)	ACTIVE (24 V)	ACTIVE (24 V)
Yellow and Green ○ ● ●	Ioniser powered, requires attention (e.g. cleaning)	ACTIVE (HV ON)	ACTIVE (24 V)	INACTIVE (0 V) <b>Will sink current</b>
Red ● ○ ○	Overload, hardware fault, supply voltage out of range	INACTIVE (HV OFF)	INACTIVE (0 V) <b>Will sink current</b>	INACTIVE (0 V) <b>Will sink current</b>
Not Illuminated ○ ○ ○	Ioniser not powered	INACTIVE (HV OFF)	INACTIVE (0 V) <b>Will not sink current</b>	INACTIVE (0 V) <b>Will not sink current</b>

**IMPORTANT:**

The OK output always directly indicates the ionisation state of the 8001.

**IMPORTANT:**

Because the outputs are implemented using an electronic switch rather than a relay, when the ioniser is not powered, the outputs will not sink current.

## 11. Remote Interface and Wiring Examples

### 11.2. Remote Interface Electrical Specifications

The **OK** and **ATTENTION** signals are designed to allow direct connection to PLC digital inputs conforming with IEC 61131-2 Type 3 characteristics. The detailed specification of the remote signalling outputs is given in the table below.

Characteristic	Specification	Notes
High-level output voltage, open-circuit	$V_{IN} - 0.5 \text{ V}$	$V_{IN}$ is nominally 24 V. High-level output voltage depends on power supply voltage.
Output impedance, high-level	3 k $\Omega$	Internal pull-up to $V_{IN}$
Maximum output current, high-level, $V_{IN} = 24 \text{ V}$ (sourcing)	8 mA	Output shorted to 0 V.
Low-level output voltage, open-circuit	0 V	Connected internally to 0 V by low-impedance switching device.
Output impedance, low-level	< 50 $\Omega$	
Maximum output current, low-level (sinking)	20 mA	Protected by internal self-resetting fuse.
Maximum externally applied voltage	28 V	Signal output is also protected against transient over-voltage.

The simplified schematic diagram below shows the implementation of the remote signalling outputs.

Circuit inside the Ioniser

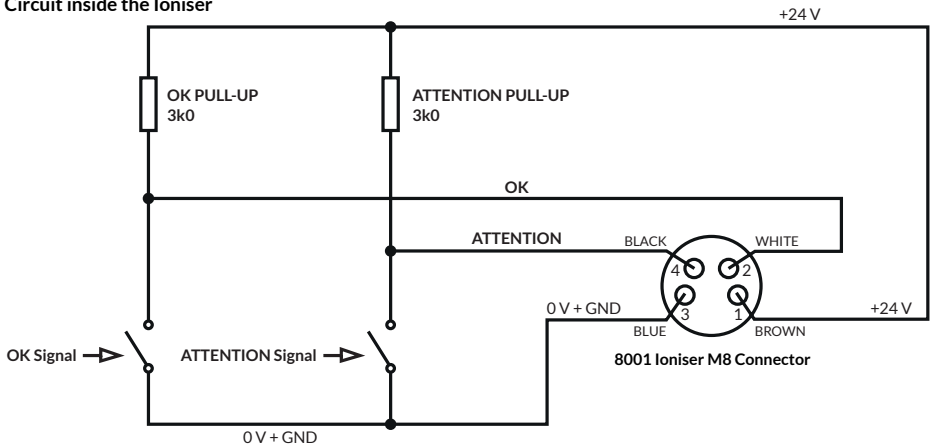

The switches in the diagram above are shown in the position corresponding to 'Ioniser powered, all OK'.

## 11. Remote Interface and Wiring Examples

### 11.3. Interfacing with PLC systems

To interface the Ioniser with a PLC digital input conforming with IEC 61131-2 Type 3 characteristics, simply connect the 'OK' and/or 'ATTENTION' outputs from the Ioniser to the PLC digital input module as shown below.

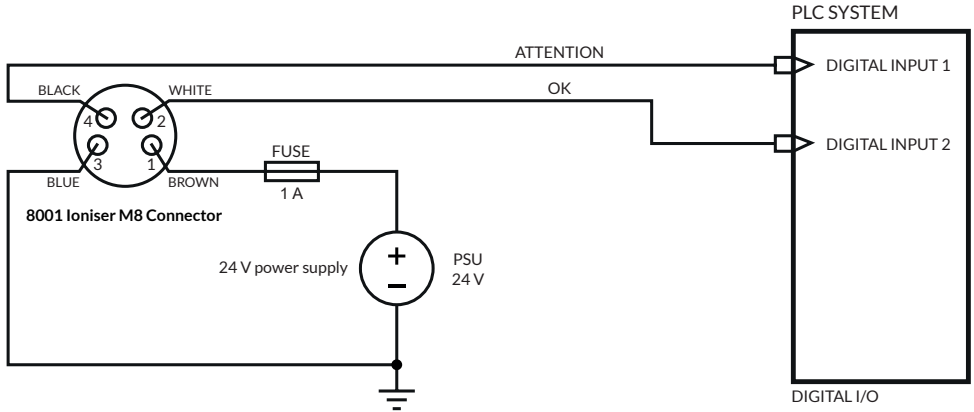

To interface the Ioniser with a PLC system having IEC 61131-2 Type 1 or Type 2 input characteristics, fit external 1 k $\Omega$  pull-up resistors to supply the current required by these input types, as shown below. These resistors should have a power rating of at least 1 W.

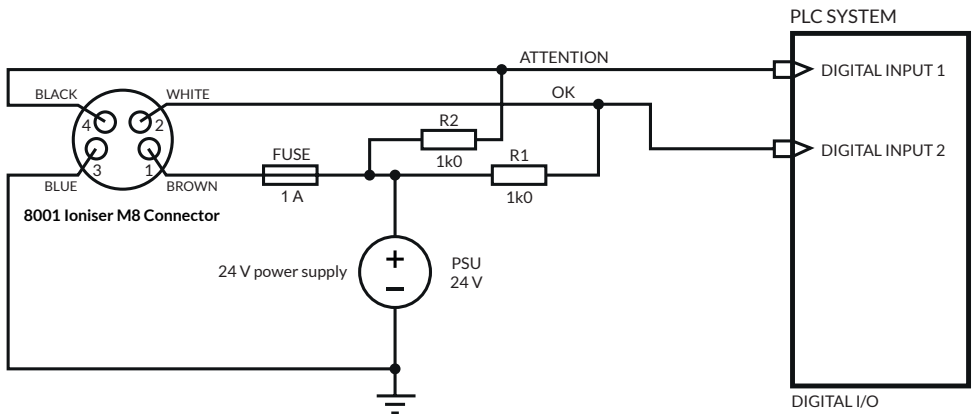

---

## 11. Remote Interface and Wiring Examples

---

### 11.4. Powering the Ioniser directly from a PLC digital output

A typical 24 V, 0.5 A, PLC output is capable of supplying the average current required by the Ioniser, and can be used to power the Ioniser directly.

It is possible that over-current trips may be experienced on PLC outputs due to the pulsing of the HV supplies in the Ioniser. This will depend on the characteristics of the PLC output module. In this case, use the PLC output to control a relay which switches the main 24 V supply to the Ioniser.

### 11.5. Connecting external indicators

Typical 24 V LED-based industrial indicators with rated current of 20 mA or less can be driven by the remote signalling outputs.

The recommended wiring scheme for external indicators is shown below. Note that the connections for the OK and ATTENTION signals are different.

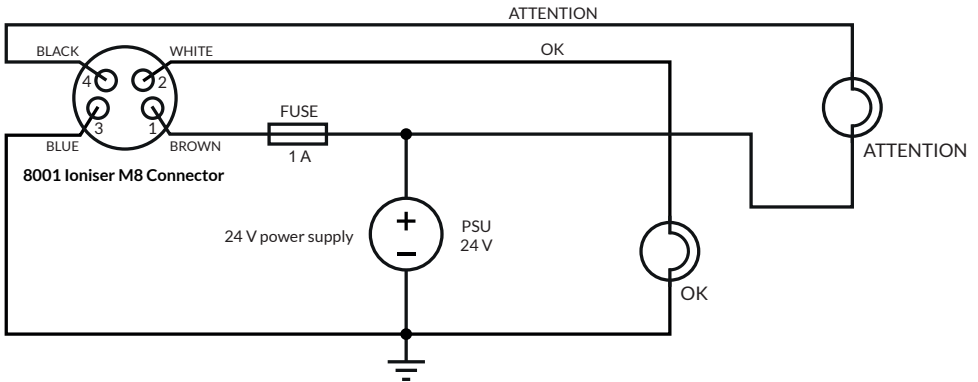

With this wiring scheme, the indicators will illuminate according to the table below.

<b>Ioniser Status</b>	<b>OK Indicator</b>	<b>ATTENTION Indicator</b>
Powered, all OK	ON	OFF
Attention required	ON	ON
Fault, overload, supply voltage out of range	OFF	ON
Ioniser not powered	OFF	OFF

**IMPORTANT:** Connecting indicators with higher current requirements to the Ioniser will not damage it, but it is unlikely that satisfactory brightness will be obtained.



---

## 11. Remote Interface and Wiring Examples

---

### 11.6. Connecting external relays

To provide potential-free contacts or switch a higher voltage or current level, relays can be installed between the Ioniser and external control circuit.

External relays must be connected with the Ioniser output sinking current to energise the relay coil.

PLC interfacing relays with high-sensitivity 24 V DC coils should be used to interface with the Ioniser. Some examples are:

- Phoenix Contact PLC-RSC series
- Finder 38 series
- Wieland FLARE-24DC series
- Omron G2RV series

**IMPORTANT:** Relay coil drive current at 24 V should not exceed 20 mA.

**IMPORTANT:** External relays should be fitted with coil suppressors.



The recommended wiring scheme for external relays (using SPCO relays) is shown below.

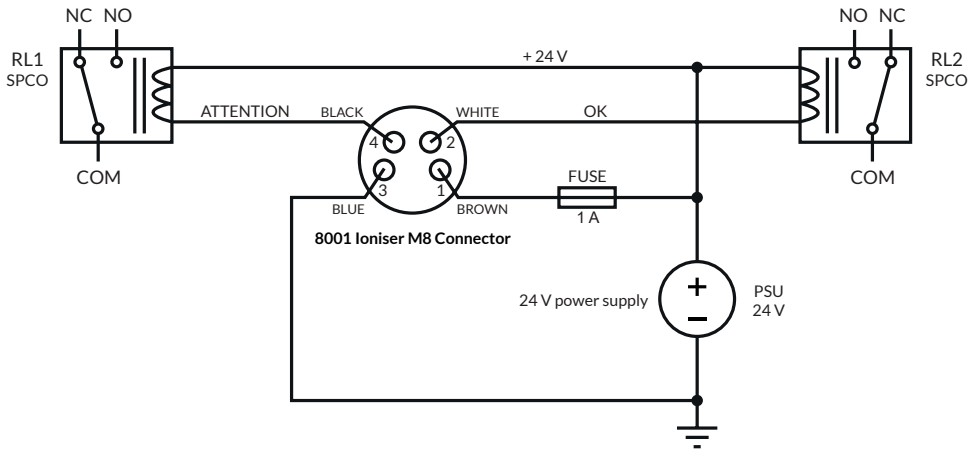

---

## 11. Remote Interface and Wiring Examples

---

The relay contacts will be connected according to the following table.

Ioniser Status	OK Relay (RL2)	ATTENTION Relay (RL1)
Powered, all OK	OPEN (COM → NC)	OPEN (COM → NC)
Attention required	OPEN (COM → NC)	CLOSED (COM → NO)
Fault, overload, supply voltage out of range	CLOSED (COM → NO)	CLOSED (COM → NO)
Ioniser not powered	OPEN (COM → NC)	OPEN (COM → NC)

**IMPORTANT:** Due to the use of electronic switches within the Ioniser, it is not possible to determine remotely that the Ioniser is not powered when using external relays.



## 12. Technical Specification

Power Supply	
Input Voltage	24 V DC nominal, 21 - 28 V operating range. 0 V earthed.
Input Current	0.1 A max
Maximum Input Power	3 W
Input Connector	M8, 4-pole, male

Output	
Ionisation Method	High frequency AC
Output Voltage	Up to 3 kV (2.2 kV, rms, sinusoidal)
Output Frequency	65 - 70 kHz
Emitter Material	Tungsten
Emitter Touch Current	10 mA, rms at 65 kHz

Monitoring	
LED Status Indication	Green: OK, ioniser operating normally Yellow and Green: Emitter requires cleaning Red: supply voltage out of range or internal fault

Air Supply	
Working Fluid	Compressed dry air (oil-free)
Working Pressure (max)	0 - 5 Bar
Working pressure (optimum)	0.5 - 2 Bar

Remote Monitor	
Signalling Outputs	'OK' and 'ATTENTION'
Signalling Levels	24 V output, 3 k $\Omega$ output impedance
Output Current	Sourcing (+24 V): 8 mA Sinking (0 V): 20 mA Limited to 50 mA max (output low) by internal protection
PLC Compatibility	Compatible with IEC 61131-2 Type 3 PLC inputs
Remote Monitor Status	Ioniser OK, Attention required, Fault, Ioniser not powered

---

## 12. Technical Specification

---

Protection	
Internal Protection	Under-voltage/over-voltage indication, surge protection, reverse supply polarity protection. HV supply protected against overload and short-circuit. Signalling outputs protected against short-circuit.





Environmental Conditions	
Ambient Temperature	0 - 55 °C
Relative Humidity	Maximum 70 % rH, non-condensing
Ingress Protection	IP52. Product may be damaged by exposure to water
Vibration	Installation location must be vibration-free

Mechanical	
Dimensions	123 x 25 x 32 mm
Weight	80 g
Materials	PVC body, stainless steel base, tungsten emitter



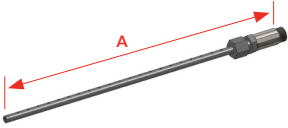
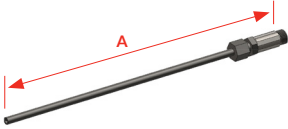
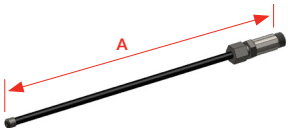

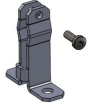
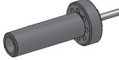





Certification/Approvals	
EU LVD (2014/35/EU)	
EU EMC (2014/30/EU)	EN 61000-6-3:2007, EN 61000-6-2:2005
Cleanroom Compatibility	ISO Class 4

### 13. Spare Parts and Accessories

A range of accessories to assist with installation and maintenance of the Ioniser is available from Fraser Anti-Static Techniques. Please contact your local distributor to enquire regarding pricing and delivery of these items.

Item Photo	Description	Part Number
	<p><b>Ion Shower Nozzle</b>            Dimension A:            - 266 mm            - 385 mm            Holes @ 10 mm pitch</p>	<p>E47001            E47002</p>
	<p><b>Fixed Precision Nozzle</b>            Dimension A:            - 263 mm            - 383 mm</p>	<p>E47004            E47005</p>
	<p><b>Flexible Shape Preserving Nozzle</b>            Dimension A:            - 266 mm            - 386 mm            - 716 mm            Minimum Bend Radius: 40 mm</p>	<p>E47008            E47009            E47010</p>
	<p><b>Conductive Flexible Tube Nozzle</b>            Length: 500 mm            Can be cut to the required length            Minimum Bend Radius: 15 mm</p>	<p>E47007</p>
	<p><b>Flexible Nozzle Extension</b>            Length: 500 mm            Can be cut to the required length            Minimum Bend Radius: 15 mm</p>	<p>E47014</p>
	<p><b>Nozzle Holder Assembly Set</b>            Mounting Holes: 2 x 4.5 mm                                      18 mm pitch            Mounting Height: 24.5 mm</p>	<p>47013</p>
	<p><b>Emitter Assembly</b></p>	<p>47012</p>
	<p><b>Spare Standard Nozzle</b></p>	<p>470002</p>

### 13. Spare Parts and Accessories

Item Photo	Description	Part Number
	3 m cable M8 female, bare ends. <b>Straight socket.</b>	80892
	5 m cable M8 female, bare ends. <b>Straight socket.</b>	80930
	7.5 m cable M8 female, bare ends. <b>Straight socket.</b>	80931
	10 m cable M8 female, bare ends. <b>Straight socket.</b>	80932
	3 m cable M8 female, bare ends. <b>90° socket.</b>	80933
	5 m cable M8 female, bare ends. <b>90° socket.</b>	80934
	7.5 m cable M8 female, bare ends. <b>90° socket.</b>	80935
	10 m cable M8 female, bare ends. <b>90° socket.</b>	80936
	Universal AC-DC power supply: 100 - 250 V AC, 24 V DC output <b>Fitted with 1.5 m of cable.</b>	E3024-PSU
	2 m M8 male to M8 female 4-pin extension cable for AC-DC power supply unit.	80937
	<b>Fraser Ioniser Cleaning Kit</b> - 500 ml of Cleaning Fluid - Soft bristle hand brush - Instructions for use	81220

---

**This page intentionally blank**

---

For more information about static and to view the full range  
of our products, please visit [www.fraser-antistatic.com](http://www.fraser-antistatic.com)



Scotts Business Park, Bampton, Devon, EX16 9DN, UK  
T + 44 (0) 1398 331114 F + 44 (0) 1398 331411  
E [sales@fraser-antistatic.co.uk](mailto:sales@fraser-antistatic.co.uk) W [www.fraser-antistatic.com](http://www.fraser-antistatic.com)