

EX-HPSD 101 / 201 STATIC DISCHARGERS

EX-HPSD 101 and 201 Static Dischargers are powerful anti-static tools which have been ATEX certified for use in hazardous areas.

Unrivalled cost-effectiveness in hazardous areas. The low cost does not mean low performance.

PERFORMANCE

- The fine conductive tips of the fibre concentrate the electric field to create ionised air which allows the static charge to flow to earth.
- EX-HPSD Static Dischargers are particularly efficient at neutralising high charge levels and can cope with high speeds.

ESSENTIAL QUALITIES

- Available in two body versions, with three fibre lengths – see specification table.
- Solvent resistant construction - to resist aggressive chemicals and to allow cleaning in the solvent used.

CONNECTIVITY AND CONTROL

- EX-HPSD dischargers must be connected to earth.

APPLICATIONS

- The tips of the fibre do not need to touch the material, but should be 2 - 3 mm from it.
- EX-HPSD dischargers are used by coaters, gravure and flexo printers and laminators worldwide.



SPECIFICATION

Construction:

EX-HPSD 101 - 2 mm extruded aluminium walls with 'h' body.
EX-HPSD 201 - compact 9.5 mm x 9.5 mm aluminium body.

Available Lengths:

EX-HPSD 101 - Any length up to 4000 mm.
EX-HPSD 201 - Any length up to 3000 mm.

Fibres:

Carbon Fibre: 6/7 µm diameter. Density of 60,000 filaments/cm.
Available with 18 mm, 30 mm or 50 mm fibre length.

Fixing:

EX-HPSD 101 - Fixing holes can be drilled in the single wall upright of the 'h' body, which has an extrusion mark to show the centreline. The M4 x 10 earthing stud is 10 mm from one end.
EX-HPSD 201 - The M4 fixing studs are 10 mm from each end and also in the middle for lengths above 1000 mm.

Certification:

CE. ATEX EX certified for use in hazardous areas.

HOW IT WORKS

Positioned about 2.5 mm from the web, the carbon fibre filaments concentrate the electric field of the static charge and ionise the gap.

This ionised air allows the exchange of ions which neutralises the charge.

The electric field from the static charge in the material is concentrated to ionise the air in the gap between the fibres and the material. This produces ions of the opposite polarity to neutralise the static charge. Unused ions travel to earth through the brush body.

DIMENSIONS AND CONSTRUCTION

Available Lengths: EX-HPSD 101 - Any length up to 4000 mm. EX-HPSD 201 - Any length up to 3000 mm.

EX-HPSD 101

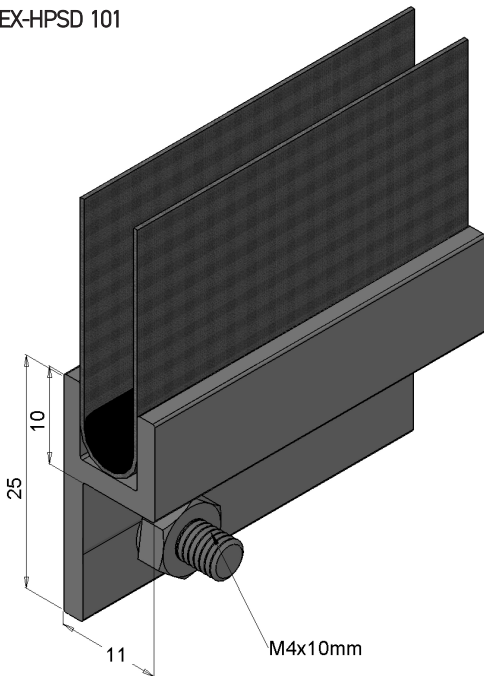

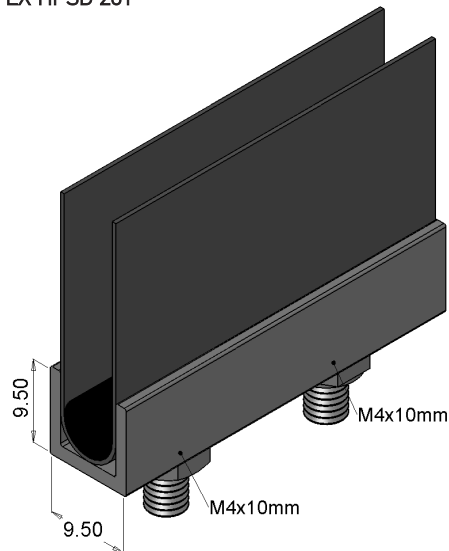

EX-HPSD 201



EX APPROVAL

EX-HPSD Anti-Static Brushes have been certified for use in hazardous areas.

Baseefa06ATEX0318 II 2 GD

EX-Anti Static Brush YYYY/NNNN		  FRASER Anti-Static Techniques
 II 2 GD Baseefa06ATEX0318		
Fraser Anti-Static Techniques, Scotts Business Park, Bampton, Devon, EX16 9DN U K		