

**7080, 7090, 7093, 7095,
7130, 7150**

Static Generation Electrodes

Operating Instructions

1.	Introduction	Page 4
2.	Safety	Page 4
3.	Use	Page 4
4.	Checking on Delivered Equipment	Page 5
5.	General Specification and Dimensions	Page 5
6.	Positioning	Page 6
7.	Maintenance	Page 7
8.	Health and Safety	Page 7
9.	Certification and EU Declaration of Conformity	Page 7
10.	Troubleshooting	Page 8

Static Generation Electrodes

1. Introduction

This manual applies to all Fraser Static Generation Electrodes.

It is essential that you read and understand the complete manual before installing and using this equipment. This is important for safety and for warranty cover.

1.1 Explanation of Symbols



Warning!

This symbol appearing in the operating instructions refers to operations which, if carried out improperly, may result in serious personal injuries.



Caution!

This symbol appearing in the operating instructions refers to operations which, if carried out improperly, may result in damage to property.

2. Safety

Fraser Generator Electrodes are intended for use in industrial applications to apply static electricity.

It is very important that the user understands the nature of this equipment. Ensure the following warnings and information contained within this manual are read and understood to prevent injury or damage.



Warnings:

- Only qualified engineers or electricians should install, operate or maintain this equipment.
- The high voltage should be turned OFF at source before carrying out any work on it.
- Do not touch any live parts of the equipment as this could result in an unpleasant electrical shock. Which could be dangerous to a person with a pacemaker or a weak heart.
- The electric field from static charging electrodes can induce a static charge in nearby machine parts - if these parts are not grounded they will be capable of giving an electric shock. Nearby machine parts must be connected to earth.
- Any changes to the equipment without written consent of the manufacturer will nullify the warranty and CE approval.

3. Use

Fraser Static Generation Electrodes which are used in industrial processes for applying electrostatic charges. They are designed for installation on machinery.

They are used in conjunction with Fraser Static Generators, which supply the high voltage.

The system consisting of the Static Generator and the Electrode are used for temporary adhesion in many areas of industry.

4. Checking on Delivered Equipment

The equipment leaves our factory in suitable protective packaging. Please check that it is undamaged when it arrives. If there is visible damage contact the Factory or one of our Distributors immediately, before carrying out any installation.

Check that the parts that which have been delivered are the same as you have ordered.

- Loose Parts: Electrode + plastic installation fixings.
- Plastic slide to cover/screen emitters, if ordered.
- Static Generator, if ordered.

5. General Specification and Dimensions

	7080 and 7081	7130 and 7150
Operating Voltage:	To 30kV.	To 50kV.
Operating Conditions:	Max 50°C.	Same.
Weight:	70% rH non-condensing.	Same.
Material: Body	PVC Body.	Same.
Resin	Epoxy.	Same.
Endcaps	FR-ABS.	Same.
Maximum o/all Length:	From 60mm to 3m.	From 90mm to 4m.
Active Length:	Overall length less 50mm.	Overall length less 75mm.
Emitters:	Hardened steel alloy. 10mm pitch.	Tungsten. Same.
Resistance between HV and emitters:	100MOhm.	170MOhm.
Cable:	2m unless ordered otherwise.	2m unless ordered otherwise.
Generator, to use with:	7080 with discontinued 7330, 7300, 7324. 7081 with 7333 and 7360. The difference is in the connector.	7130 with 7333, 7360, (not discontinued models) 7150 has connector for 50kV Generators only. The difference is in the connector.

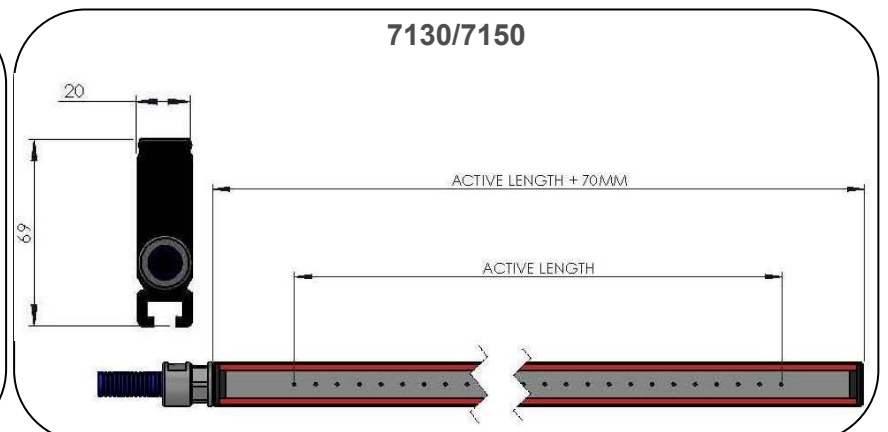
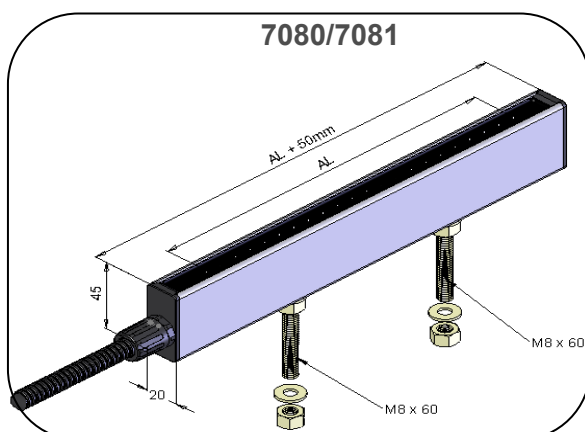

6. Positioning

Operating Distance: Guidelines: minimum 20mm to object for 30kV, + minimum of 2mm per extra kV above 30kV e.g if operational voltage is 40kV then minimum distance to object is 40mm. The best distance is achieved by experiment.

Mounting: The M8 nylon mounting bolts should be used for installation. One M8 bolt is needed every 500mm to maintain rigidity.

Important: There should be no metal parts within 50mm of the electrode for 30kV or within 75mm for 50kV. If this is not followed there is a risk of electrical break down or poor performance.

All metal parts within 500mm of the electrode must be earthed.

Keep cables away from grounded surfaces. Max bend radius 50mm.

There must always be an electrode and a counter electrode on the other side of the materials which are to be stuck together electrostatically. The counter electrode is to allow mirror-image ions of the opposite polarity to be generated. The efficiency of the process depends on the counter electrode. The normal methods of achieving adhesion between two non conductive materials, and the options for the counter electrode, are shown below.

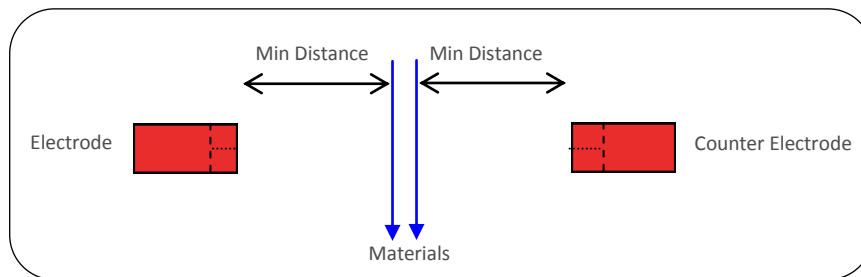

	<u>Electrode</u>	<u>Materials</u>	<u>Counter Electrode</u>
A)	7080 or 7150	7080 / 7150 of opposite polarity	Best Adhesion
B)	Ditto	Ionising Bar, e.g. 1250-S	Good adhesion
C)	Ditto	Anti-Static Brush, earthed	Good adhesion
D)	Ditto	Earthed metal rod	Moderate adhesion

Where a non-conductive material is to stick to a conductive material the process is simpler. The conductive material must be earthed but there is no need for a counter electrode.

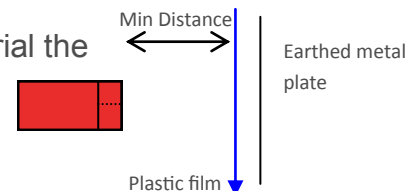

In this application if the plastic film is smaller than the effective length of the electrode it is important to mask any emitter pins which can “see” the metal. The photo shows the Emitter Mask supplied by Fraser - part 715003, which clips into the grooves on the 7150 Bar. The 7080 does not have a similar part, but strong insulation tape can be used by the customer as an alternative.



7. Maintenance

The high voltage should be turned **OFF** at source before carrying out any maintenance.



Static generator electrodes should be kept clean - dust and contaminants around the emitters and body will waste energy, reduce performance and lead to a breakdown of insulation and failure of the bar electrode.

Cleaning is the only maintenance required. Dirt around the emitters will reduce efficiency and result in unsatisfactory performance. A soft toothbrush is ideal for cleaning Bars. Do not use a wire brush as this could damage the Bar. The Bar can be washed with soapy water or IPA, but it must be dry on the inside of the Bar around the emitters before turning the power on.

When cleaning around the emitters - take care as the pins are sharp!



8. Health and Safety

The ozone generated by this product is less than 0.1ppm and within internationally accepted limits. Please note, when handling and cleaning, that the emitter pins are sharp and care is needed.



9. Certification and CE Declaration of Conformity

We declare that this equipment conforms to the following EC Directives:

Low Voltage Directive: 2006/95/EC.

EMC Directive: 2004/108/EC

And is entitled to display the CE Mark.

For further instructions and information, please contact the manufacturer.

10. Troubleshooting

Fault	Sparking - Electrode too close to an earthed surface.
	<ul style="list-style-type: none">• Increase distance.• Cover emitters so that they do not “see” metal parts . See emitter mask on page 3.• Check that energy is not tracking through dirt - clean the electrode.

Fault	No Energy.
	<ul style="list-style-type: none">• Check HV Supply from Generator.

Fault	Performance not satisfactory.
	<ul style="list-style-type: none">• Check optimal distance between electrode and product - adjust as necessary.• Dirty electrode - clean.• Check conductivity of material - if paper it must be $>10^{10}$ Ohm per Square. Check using a Model 730 SRM.• Material already charged - Neutralise it with a Static Eliminator.

Fraser Anti-Static Techniques Ltd. Tel: +44 (0) 1398 331 114 Fax: +44 (0) 1398 331 411
E-mail: sales@fraser-antistatic.co.uk W: www.fraser-antistatic.co.uk

The Fraser range of Static Control equipment includes the following:

La gamme Fraser d'équipements de contrôle de l'électricité statique comprend les produits suivants:

Das Produktprogramm von Fraser umfasst folgende Geräte:



LONG RANGE Static Neutralisation
Neutralisation statique LONGUE DISTANCE
Statikneutralisierung auf GROSSE ENTFERNUNG



SHORT RANGE Static Neutralisation
Neutralisation statique COURTE DISTANCE
Statikneutralisierung auf KURZE ENTFERNUNG



DUST REMOVAL and CLEANING
ÉLIMINATION DE LA POUSSIÈRE et NETTOYAGE
STAUBENTFERNUNG UND REINIGUNG



PASSIVE Static Neutralisation
Désélectriseurs INDUCTIFS
PASSIVE Ionisatoren



STATIC GENERATION
GÉNÉRATION D'ÉLECTRICITÉ STATIQUE
STATIKERZEUGUNG



MEASURING
MESURE
MESSUNG



For more information about static and a full range of our products, visit our website at:

www.fraser-antistatic.co.uk

Scotts Business Park,

Bampton,

Devon.

EX16 9DN

United Kingdom

Tel: +44 (0) 1398 331114

Fax: +44 (0) 1398 331411

E: sales@fraser-antistatic.co.uk