

SOLUTIONS TO STATIC PROBLEMS

PLASTICS

IML METHOD 1 - DIRECT CONTACT PLACEMENT INTO MOULD

Step 1:

- Robotic arm picks up labels from a stack using a vacuum.

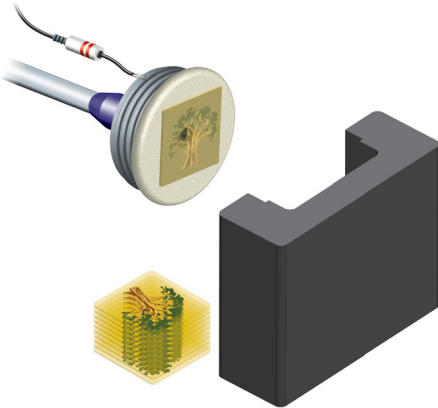

Step 2:

- The label is delivered to the tool and the vacuum released upon contact.
- At the same time voltage is applied from the 7330 static generator to the charge plate, IML contact pad and label for a short time via the 7091 inline resistor.
- The robotic arm withdraws leaving the label adhered to the inside of the tool cavity.

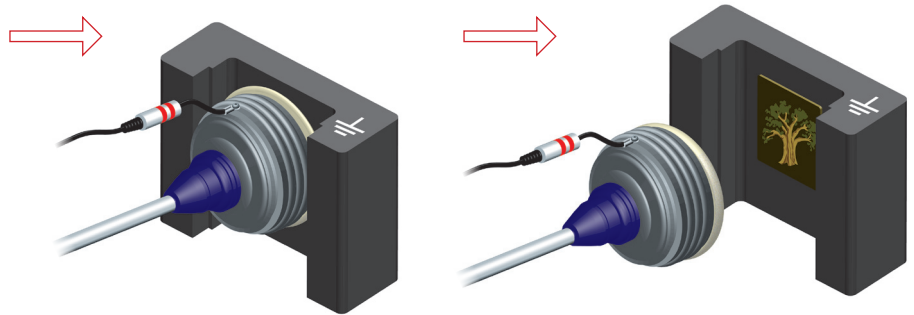

Essential Information:

- Crushable IML Contact Pad is always 15mm > in size all round than the metal charge plate.
- The voltage 7-12kV should be applied for 35-60 milliseconds to the charge plate as contact between the label and tool is made.

7091 Inline resistor (HVHT Cable with 100Meg Ω resistor)

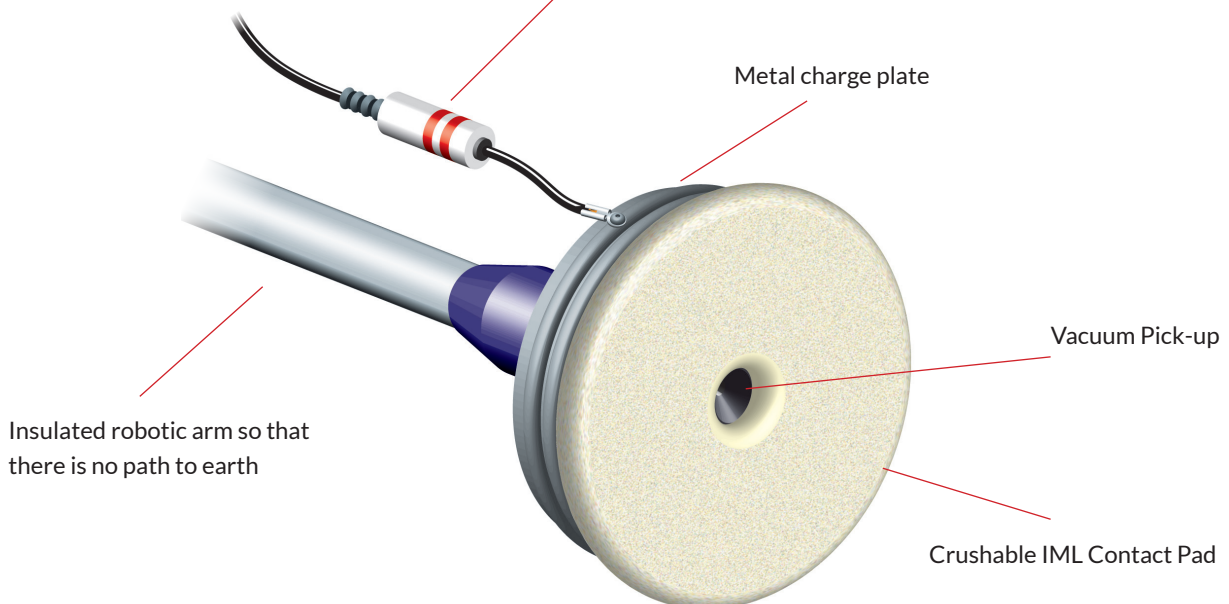

SOLUTIONS TO STATIC PROBLEMS

PLASTICS

IML METHOD 1 - DIRECT CONTACT PLACEMENT INTO MOULD, CONT.

Some carriers on the robotic arms are not flat plates but are cones or cylinders that carry the label into the female tool cavity for cups etc.

Step 1:

- Air Jets blow label edges around carrier to be pulled in by vacuum ports.

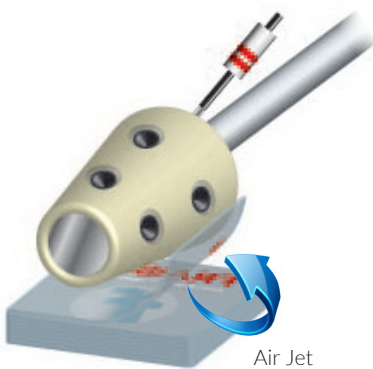

Step 2:

- The label is delivered to the tool cavity and the vacuum released upon contact.
- At the same time voltage is applied to the charge plate, IML contact pad and label for a short time.
- The robotic arm withdraws leaving the label adhered to the inside of the tool cavity.

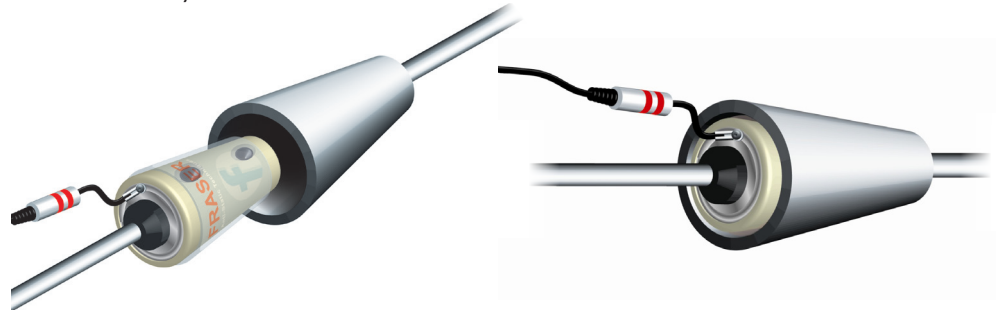

Vacuum Pick-up

Metal Mandrill

Crushable IML Contact Pad overhangs the mandrill by approximately 15mm

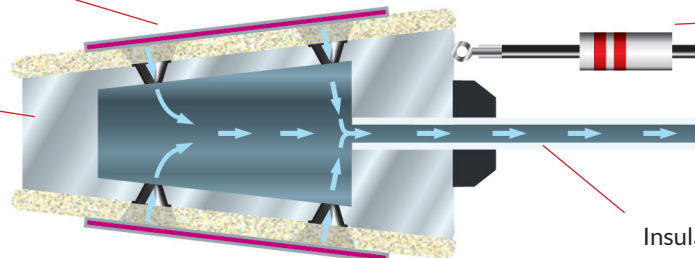

7091 Inline resistor (HVHT Cable with 100Meg Ω resistor)

Insulated robotic arm so that there is no path to earth

7091—Inline resistor



E70-IML-HW-RT

For multi-impression tool an E70-IML-HW is required which is able to charge up to 8 metal charge plates simultaneously

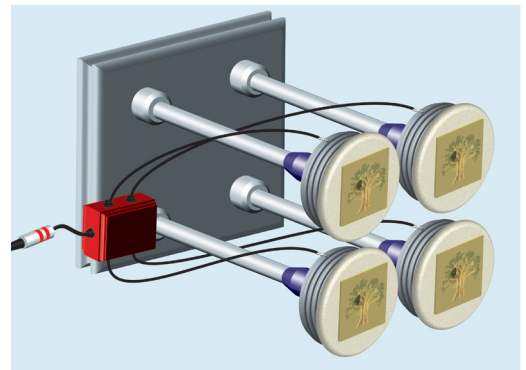

SOLUTIONS TO STATIC PROBLEMS

PLASTICS IML METHOD 2 - LABEL BLOWN INTO MOULD

Method 2—utilises charging heads to generate static which gives the label a charge and enables it to adhere to the inside of the tool with air assistance.

Step 1:

- Robotic arm picks up labels from a stack using a vacuum.

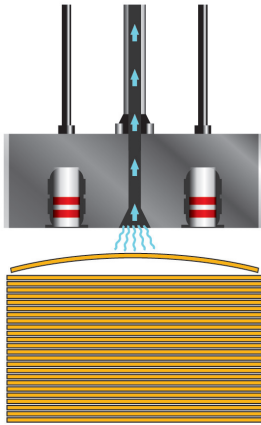

Step 2:

- The vacuum is released and the heads are activated as the label is blown into the tool.
- The tool acts as the earth back to the generator—there is no contact made between the carrier arm and the tool.

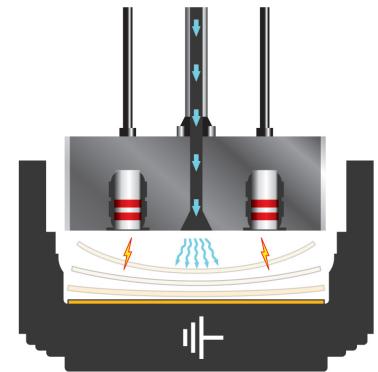
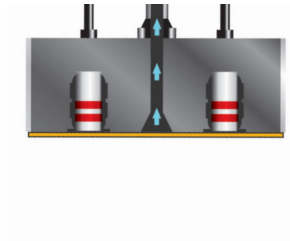

Essential information:

- For multiple impression tools the E70-IML-HW-CDH is available with a maximum of 8 charging heads and 14m cable.
- The heads are hardwired into the connector box which is fitted with a 100Meg Ω resistor.

7090 Single Point Generator



E70-IML-HW-RT

Plastic Carrier

7090 Single Point Generators

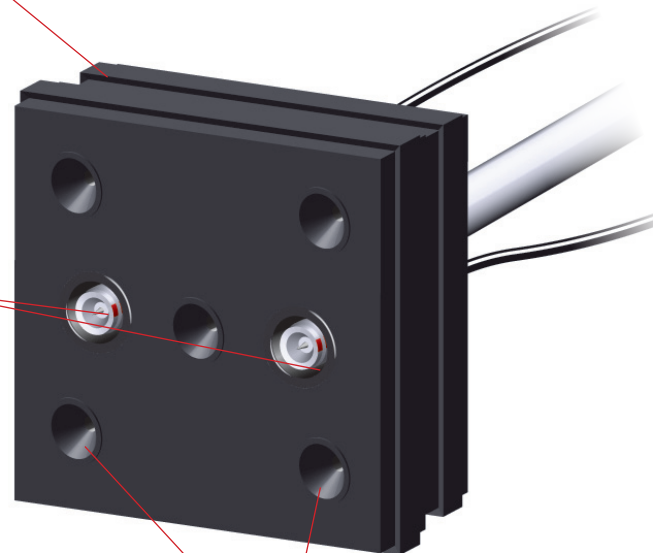

Vacuum Pick Ups

SOLUTIONS TO STATIC PROBLEMS

PLASTICS

IML METHOD 3 - LABEL BLOWN ONTO MANDRILL

Method 3—For cups and similar the labels can be applied to the male tool (mandrill) rather than into the tool cavity as in method 1.



7090 Single Point
Generator

Step 1:

- Air jets blow the label down and around the mandrill, once in position the label is fixed to the tool by static using 7090 Single Point Generators

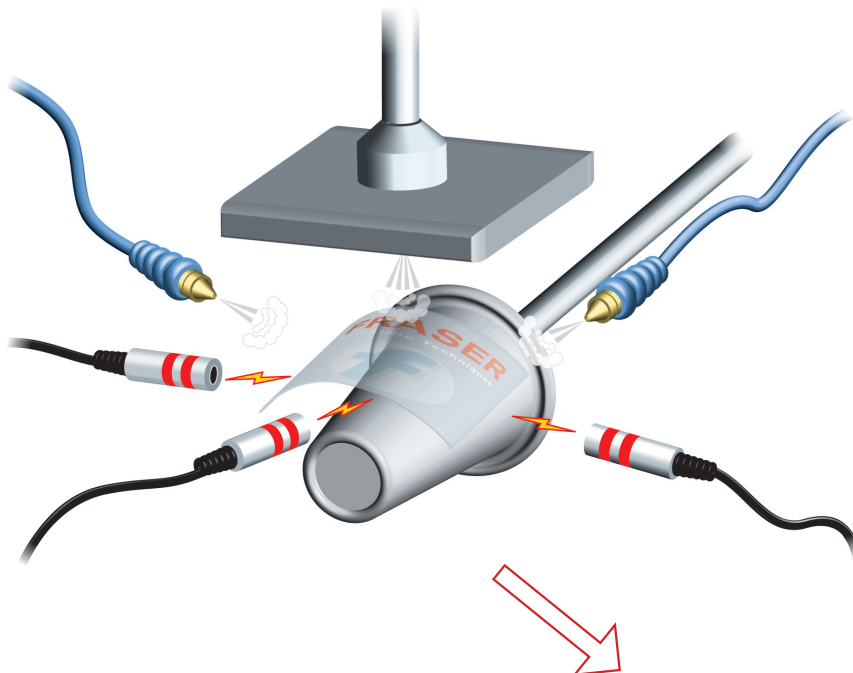

Step 2:

- The mandrill carrying the label is then introduced into the cavity and remains there throughout the injection moulding process.

