



IONFIX COMPACT
WITH CONSTANT-POWER OPERATION



Fraser static control equipment has been designed to give you many years of productive service. However, the science of static control has unique rules which must be followed to allow the equipment to give a good return on your investment.



Please read the following operating and maintenance instructions carefully.

Contents	Page
1 Introduction	4
2 Safety	5
3 Use and Operation	7
4 Installation	9
5 Commissioning and Operation	15
6 Remote Interface	22
7 Technical Specifications	32
8 Troubleshooting	35
9 Maintenance and Repair	36
10 Disposal	36
11 Spare Parts	37

1. Introduction

This manual applies to the Fraser IONFIX Compact Generator product range:

- IONFIX Compact, 24 V DC input, 30 kV DC output, positive or negative output polarity.
- IONFIX Compact, 90 - 250 V AC input, 30 kV DC output, positive or negative output polarity.
- IONFIX Compact IML, 24 V DC input, 20 kV DC output, positive or negative output polarity.
- IONFIX Compact IML, 90 - 250 V AC input, 20 kV DC output, positive or negative output polarity.

It is essential that you read and understand the complete manual before installing and using this equipment. This is important for both safety and warranty cover.

Where the word 'generator' is used within this manual, it refers exclusively to the Fraser IONFIX Compact Generator.

1.1. Explanation of Symbols

Warning!

This symbol appearing in the operating instructions refers to operations which, if carried out improperly, may result in serious personal injuries.



Caution!

This symbol appearing in the operating instructions refers to operations which, if carried out improperly, may result in damage to property.



Information!

This symbol refers to information which relates to obtaining the best performance and operating life from the product.



2. Safety

2.1. Safety Concepts

The Fraser IONFIX Compact is a high-voltage switched-mode power supply. The high-voltage output of the generator is a Class 2 electrical energy source. This means that it is capable of causing pain if contact is made with a body part, but is not likely to cause an injury requiring medical attention.

Do not handle the high voltage connectors when the output is enabled. Turn off the high voltage output before handling the connectors.

The product generates high voltage at its outputs. It should be configured and installed by competent persons.

The product must be installed such that operators do not come in to contact with the high voltage connectors.

2.2. AC-powered Generator Variant

The user-accessible remote interfacing circuits of the generator are isolated from mains voltages by an AC-DC power supply.

Warning: The AC-powered variant of the IONFIX Compact contains potentially lethal voltages. Disconnect the mains supply and wait 5 minutes to allow the stored energy within the mains power supply unit to be automatically discharged.



2.3. DC-powered Generator Variant

Warning: The negative pole of the 24 V DC supply provided to the generator must be permanently earthed.



2.4. Safety Warnings

- Installation and maintenance work on the generator must only be carried out by suitably qualified personnel.
- The protective earthing (PE) terminal of the generator must be permanently connected to the main earthing terminal of the electrical installation by a conductor of at least 1.5 mm² cross-sectional area.
- Disconnect the power supply before performing any installation and maintenance work on the generator or electrodes.
- Connect only approved charging accessories to the high voltage outputs of the generator.
- Avoid contact with the high-voltage output connector and the charging electrode(s) when energised.



2. Safety

- Do not insert or remove high voltage connectors when the generator is powered or its output energised.
- Any changes to the equipment without written consent of the manufacturer will invalidate the warranty and CE/UL certification.

3. Use and Operation

The Fraser IONFIX Compact is a controlled high-voltage power supply designed to power charging electrodes providing temporary adhesion between materials in industrial applications.

The IONFIX Compact has simple front-panel controls allowing the output voltage to be set precisely to match the process requirements. The output current is electronically limited, and this limit may be reduced if necessary to suit the particular application.

The IONFIX Compact has a remote control interface, providing remote switching of the high-voltage output and remote setting of the output voltage. Overload or fault conditions are also signalled on this interface, allowing remote monitoring of the generator.

The unique flexible power control feature of the generator allows it to provide a higher output current at lower voltages, maintaining full charging power over a wider range of output voltages.

3.1. Overview



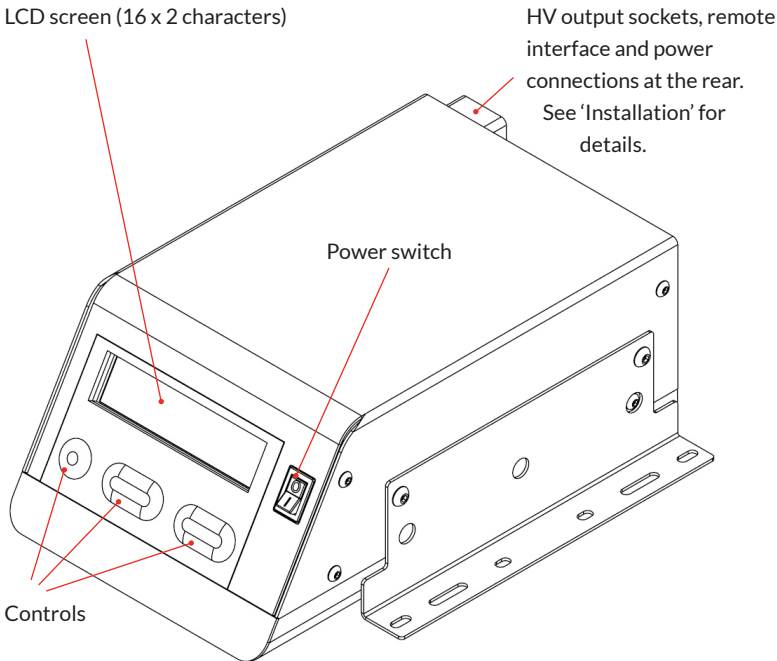

The diagram below shows the main features of the IONFIX Compact generator.



3. Use and Operation

3.2. Accessories

Fraser Anti-Static Techniques manufacture a range of compatible charging electrodes to suit many temporary adhesion applications:

Item	Description	Part No.	Item	Description	Part No.
	Generator Bar	7081		Static Pinner	7095
	Static Pinner	7090		Generator Bar	7130
	Static Edge Pinner	7093			

3.3. IML Accessories

Fraser IML Accessories have been developed to complement the IONFIX Compact and to give the IML processor the versatility to meet the demands of each job.

Item	Description	Part No.	Item	Description	Part No.
	Connector Box	7700		Single Point Electrode	771-R
	Single Pin Electrode	772		IML Ring Terminal	773
	Splitter Box	7701		Silicon Cable	81319
	Plated Emitter Pins	81036		Static Dissipative Foam	7400
	Static Wand	7097			

Your local Fraser distributor can advise on the use and installation of these electrodes. Alternatively, please visit our website (www.fraser-antistatic.com) for further information on applications of these products.

4. Installation

4.1. Checking on Delivered Equipment

The equipment leaves our factory in suitable protective packaging. Please check that it is undamaged when it arrives.

If there is visible damage contact the supplier immediately.

Check that the parts which have been delivered are the same as you have ordered.

4.2. Front Panel Rotation

The front panel display and controls of the generator may be rotated by 180° in order to accommodate different mounting orientations.

To rotate the display from 'desktop' to 'wall-mounted' orientation, follow the steps below:

1. Ensure the generator is switched off and disconnected from its power supply (24 V or mains connection isolated and removed).
 - a. **AC variant:** allow 5 minutes for stored charge to dissipate before opening cover.
Perform this operation in a clean and dry environment.
2. Remove the 8 M4x8 mm screws securing the lid of the generator using a 3 mm hex key or driver.
3. Remove the 2 M3 screws securing the front panel assembly to the generator chassis (underneath the generator).
4. Undo the 4 M3x15 mm threaded spacers securing the display and control assembly to the generator front panel, using a 5.5 mm spanner.
5. Rotate the display and control assembly by 180°. Ensure that the flexible cable connecting the display and controls to the main PCB does not become trapped or kinked.
6. Secure the display and control assembly in its new orientation, then re-fit the front panel assembly to the generator chassis.
7. Replace the lid and secure using the 8 M4 screws.



4. Installation

4.3. Mounting

The generator is provided with mounting brackets to allow mounting to a wall or panel, under a table or shelf, etc. Use only the hardware provided (M5x10 mm) to affix the mounting brackets to the generator.

If wall-mounted, use fixings suitable for the wall material and generator weight to secure the generator. Ensure that the generator is securely mounted and that all mounting fasteners have been tightened before use.



4.4. Earthing

The M5 protective earthing (PE) terminal of the generator must be permanently connected to the main earthing terminal of the electrical installation by a conductor of at least 1.5 mm² cross-sectional area.

DC variant: the 0 V rail of the 24 V supply **MUST** be permanently connected to earth.

AC variant: an earthed IEC 320 C13 cable **MUST** be used with the generator, and the socket outlet supplying the generator **MUST** be earthed correctly.



4.5. Electrical Installation

This section describes the electrical installation of the generator. The electrical connections are shown in the following sections.

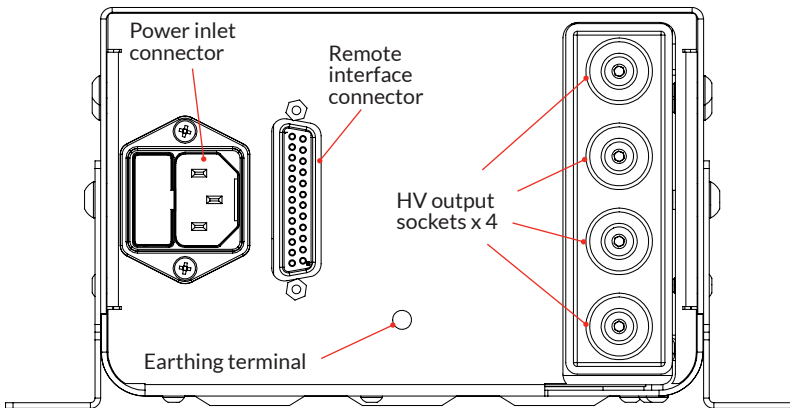

Rear view of the generator. AC IEC power inlet connector shown for example.

4. Installation

1. Ensure that the generator is earthed as described opposite.
2. Connect the high-voltage electrode(s) to the HV output sockets at the rear of the generator. Note that the 4 sockets are internally connected in parallel. Ensure that any unused sockets are plugged with the supplied blanking plugs (Fraser Part No. 730218) to prevent dirt ingress.
 - Do not route HV cables near to sharp metal components.
 - Avoid bends or kinks in the HV cables.
 - Route HV cables separately from low-voltage cables.
 - Keep HV cables as short as practically possible.
3. Connect the remote interface cable to the 25-way D-type connector at the rear of the generator. For details of the remote interface, see 'Remote Interface' section of this manual.
4. Connect the power input cable to the generator.
 - a. **DC variant:** 'Combicon' connector.

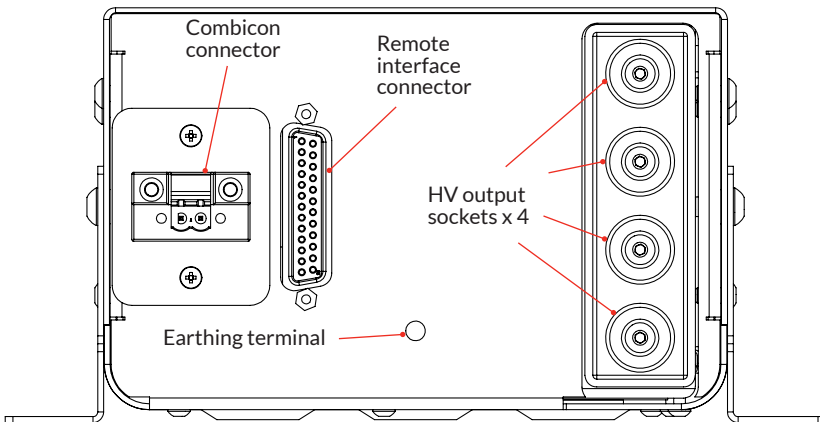

Rear view of the generator. 24 V DC Combicon power inlet connector.

4. Installation

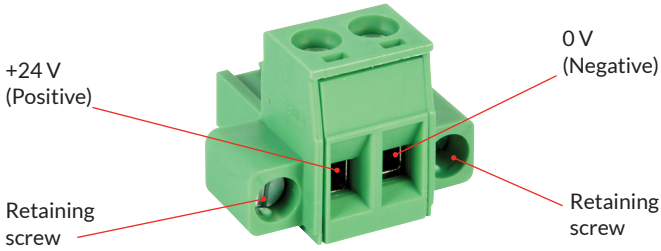

Combicon power inlet connector.

Connect +24 V to the left-hand terminal of the 'Combicon' pluggable terminal block (viewed from rear of generator), and 0 V to the right-hand terminal of the 'Combicon' pluggable terminal block. It is recommended to fit bootlace ferrules to the stripped ends of the 24 V input cable. Insert the terminal block into the 'Combicon' socket at the rear of the generator and tighten the retaining screws.

b. DC variant: M12 connector

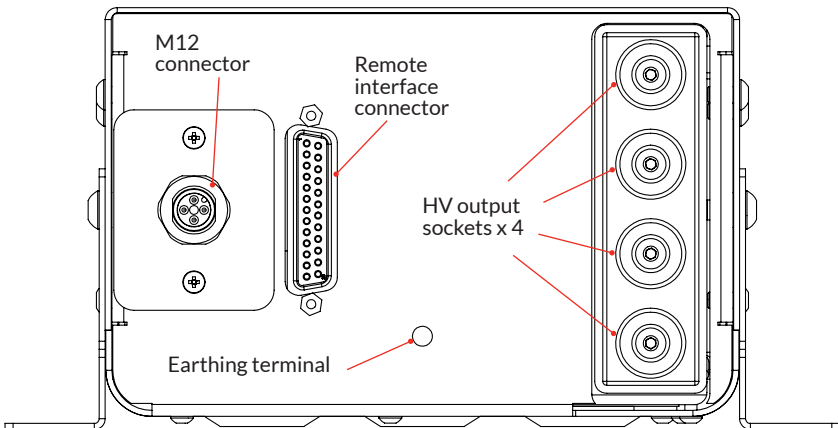

Rear view of the generator. 24 V DC M12 power inlet connector shown.

4. Installation

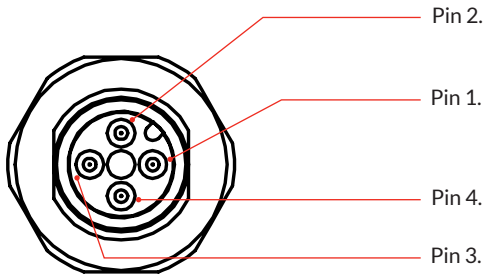

M12 power inlet connector.

Align the pins on the cable to the pins on the connector on the rear panel of the generator. Connect the cable to the connector and turn the locking ring to the right to secure the cable.

The pin assignments on the cable are as follows:

Pin No.	Wire colour	Assignment
1	Brown	+24 V DC. Pins 1 and 2 must be joined together.
2	White	+24 V DC. Pins 1 and 2 must be joined together.
3	Blue	0 V / Earth. Pins 3 and 4 must be joined together and to the Earth at the electrical supply.
4	Black	0 V / Earth. Pins 3 and 4 must be joined together and to the Earth at the electrical supply.

4. Installation

c. AC variant: IEC connector

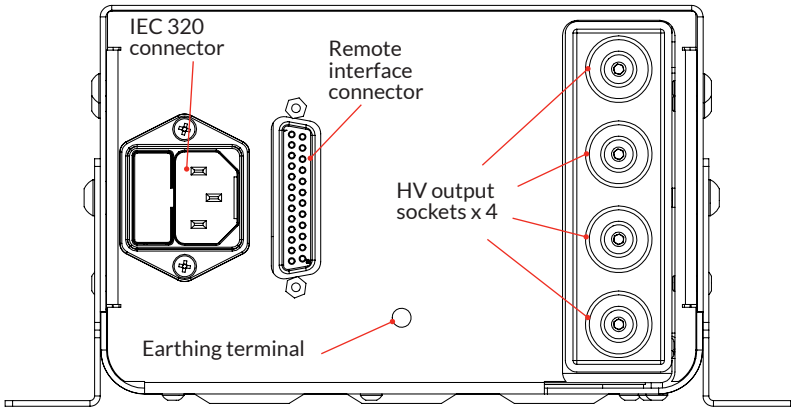

Rear view of the generator. AC IEC power inlet connector shown.

Insert the IEC 320 C13 plug into the socket at the rear of the generator.
Make sure that the IEC plug is fully and firmly seated.

5. Connect the power input cable to the supply.

- a. **DC variant:** connect the 24 V and 0 V lines to the 24 V DC supply of the machine/control cabinet.

The 0 V rail of the 24 V supply **MUST** be permanently connected to earth.

- b. **AC variant:** connect the plug to an earthed socket outlet, or into the AC supply of the machine/control cabinet.



5. Commissioning and Operation

For advice about tuning the generator settings to best suit a particular process, please contact your local Fraser representative.

Before turning the generator on for the first time, ensure that:

- The power input and case are correctly grounded as described in 'Electrical Installation'.
- The charging electrodes are correctly connected to the output sockets, with no loose connections or damaged cables.
- Any wiring connected to the remote interface is configured correctly. If the remote interface is configured to override the front panel controls, ensure that the charging electrodes becoming energised does not pose a safety risk.
- The generator is securely mounted.



5.1. Generator Front Panel Controls and Display

The diagram below shows the front panel controls and display of the generator. The function of the controls is described in brief below the diagram.

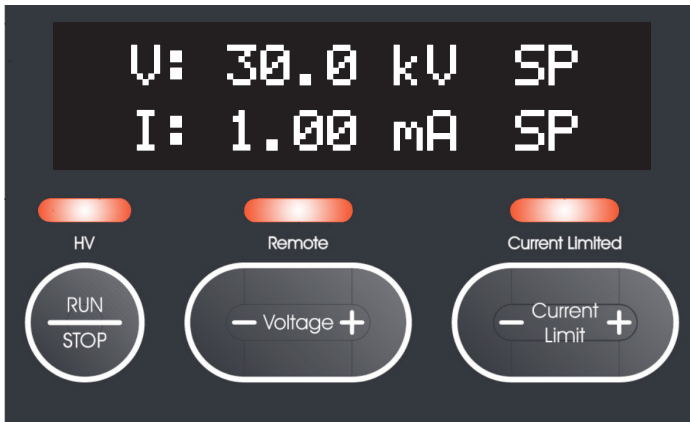

- **Display:** Indicates the settings and output parameters of the generator, and any warning messages.
- **LED Indicators (HV, Remote, Current Limited):** Show the operating status of the generator at a glance.
- **RUN/STOP Button:** Toggles the high voltage output of the generator on and off.
- **Voltage +/- Buttons:** Allow the high voltage output level of the generator to be adjusted. The IML models restrict the output voltage to 20 kV.
- **Current Limit +/- Buttons:** Allow the output current limit level of the generator to be adjusted.

5. Commissioning and Operation

5.2. Operating the Generator

Switching the generator on

To power up the generator, put the main power switch on the front panel into the 'ON' position.

The LCD backlight will illuminate and the following text will be displayed on the screen as the generator initialises and performs self-checks:

```
Fraser IONFIX C+
Startup = V: xxx
```

Note: 'V: xxx' is the software level of the generator.

The LCD will then switch to the normal operating display (positive generator shown):

```
V: 0.0 kV SP
I: 1.00 mA SP
```

If any of the generator remote interface functions are enabled the 'Remote' LED indicator will illuminate. Note that in this case, the HV output of the generator may be enabled remotely at any time.



If the remote on/off function is not enabled, the generator HV output will always be OFF when the generator is powered up. If it is necessary for the generator to power up with the HV output enabled, use the remote on/off function to achieve this.



5.3. Setting Output Voltage

When the HV output is not enabled, the generator voltage and current limit values are shown on the display, along with 'SP' to indicate that these are setpoint values.

When delivered, the generator output voltage is set to 0.0 kV. The setpoint value is stored in non-volatile memory and does not need to be re-set every time the generator is powered on.

To adjust the generator output voltage setpoint, use the 'Voltage +' and 'Voltage -' buttons. For example, if the voltage setpoint was increased to 12.5 kV, the following would be displayed:

```
V: 12.5 kV SP
I: 1.00 mA SP
```

5. Commissioning and Operation

Press the appropriate button once to increase or decrease the voltage in 0.1 kV steps. Press and hold the appropriate button to make larger adjustments. The IML models restrict the output voltage to 20 kV.

On negative polarity generators, the 'Voltage +' button increases the magnitude of the voltage setpoint, making it more negative. This corresponds to a greater pinning effect at the generator electrode.



If the voltage setpoint is adjusted whilst the HV output is enabled, the setpoint value followed by 'SP' will be shown briefly on the display.



5.4. Setting Current Limit

The output current of the generator is electronically limited to protect the generator and minimise electrode wear. The current limit level can be adjusted using the front-panel controls. By default, the generator current limit is set to its maximum value of 1 mA. The current limit value is stored in non-volatile memory and does not need to be re-set every time the generator is powered on.

When the current limit is active, the 'Current Limited' LED indicator will illuminate.



If the voltage setpoint is greater than 20 kV, the actual current limit will be reduced accordingly to maintain a maximum output power of 20 W. At 30 kV, a maximum of 0.66 mA is available. The IML models restrict the output voltage to 20 kV.

The current limit value can be set to 1 mA independently of voltage setpoint, however the full 1 mA is only available at 20 kV or less.



30 kV models only. Not IML models.

For example, if the voltage setpoint is 30 kV and the current limit is 0.8 mA, the following sequence describes the behaviour of the generator as the load is increased (numbers refer to the diagram on page 18):

1. Output voltage 30 kV, current increasing from 0 to 0.66 mA. Output power < 20 W.
2. Output voltage reducing from 30 kV, current increasing from 0.66 mA towards 0.8 mA. Output power = 20 W.
3. Output voltage 25 kV, output current 0.8 mA. Output power = 20 W
4. Output voltage reducing below 25 kV, output current limited to 0.8 mA. Output power < 20 W.

5. Commissioning and Operation

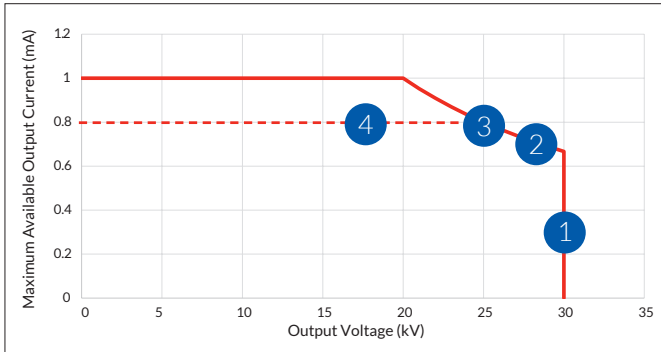

With a voltage setpoint greater than 20 kV, the 'Current Limited' LED indicator will illuminate if the 20 W power limit is reached, even if the programmed current limit is not reached.



To adjust the current limit, use the 'Current -' and 'Current +' to change the setpoint value. For example, if the current limit was reduced to 0.5 mA, the following would be displayed:

```
V: 12.5 kV SP
I: 0.50 mA SP
```

If the current limit is adjusted whilst the HV output is enabled, the setpoint value followed by 'SP' will be shown briefly on the display.



5.5. Switching High Voltage On/Off

To enable the high voltage output of the generator, press the 'RUN/STOP' button. The 'HV' indicator LED will illuminate to signal that the High Voltage output is active, and 'SP' will be replaced with 'OP' on the LCD. This indicates that the displayed values are the present measured outputs.

```
V: 12.5 kV OP
I: 0.31 mA OP
```

5. Commissioning and Operation

If the remote on/off function is not enabled, the RUN/STOP button toggles the high voltage output on and off.

If the remote on/off function is enabled, but the HV output is not turned on via the remote interface, the RUN/STOP button can be used to temporarily override the remote on/off input for testing or commissioning purposes. If the HV output is already turned on via the remote interface, the RUN/STOP button will have no effect.

5.6. Operation with Remote Interface Active

This section describes the operation of the front panel display and controls when the remote interface is in use. For details of the remote interface, see the 'Remote Interface' section of this manual.

5.7. 'REMOTE' LED Indicator

If any of the remote control functions (remote on/off, remote voltage setpoint, remote current limit) are enabled via the remote interface connector, the 'REMOTE' LED indicator on the generator front panel will illuminate.



If the remote on/off function is enabled, the HV output of the generator could be enabled at any time via a remote signal.



5.8. Remote On/Off Input

If the remote on/off input is enabled, the 'REMOTE' LED indicator will illuminate as described above. When the HV output is enabled using the remote on/off input, the 'HV' indicator will illuminate.

5.9. Remote Voltage Setpoint

If the remote voltage setpoint function is enabled, an 'R' will be added to the 'SP' or 'OP' after the voltage readout on the generator display.

For example, with HV off and remote voltage setpoint enabled:

```
V: 17.2 kV RSP
I: 0.50 mA SP
```

5. Commissioning and Operation

With HV on and remote voltage setpoint enabled:

V: 17.2 kV ROP
I: 0.16 mA OP

If the front panel voltage adjustment buttons are pressed in this state, the following error message will be shown:

REMOTE VOLTAGE
SETPOINT ACTIVE!

5.10. Remote Current Limit

If the remote current limit function is enabled, an 'R' will be added to the 'SP' or 'OP' after the current readout on the generator display.

For example, with HV off and remote current limit enabled:

V: 14.5 kV SP
I: 0.32 mA RSP

With HV on and remote current limit enabled:

V: 10.1 kV OP
I: 0.32 mA ROP

If the front panel current limit adjustment buttons are pressed in this state, the following error message will be shown:

REMOTE CURRENT
LIMIT ACTIVE!

5. Commissioning and Operation

If both the remote voltage setpoint and remote current limit are enabled, the following will be shown (HV off):

U: 17.2 kV RSP
I: 0.32 mA RSP

HV on:

U: 14.3 kV ROP
I: 0.32 mA ROP

6. Remote Interface

The generator is equipped with a remote control and monitoring interface permitting remote setting and operation of the generator.

The following functions are provided:

- **Remote on/off enable:** enables operation of the remote on/off input.
- **Remote on/off input:** permits the HV output of the generator to be switched on or off using a voltage signal.
- **Remote voltage setpoint enable:** enables operation of the Remote voltage setpoint input, overriding the value set using the front panel controls.
- **Remote voltage setpoint input:** permits the HV output of the generator to be controlled from 0 - 100 % according to an analogue voltage signal, e.g. from a PLC output.
- **Remote current limit enable:** enables operation of the Remote current limit input, overriding the value set using the front panel controls.
- **Remote current limit input:** permits the output current limit of the generator to be controlled from 0 - 100 % according to an analogue voltage signal.
- **Operating signal output:** signals when the generator is operating normally.
- **Overload/limit signal output:** signals when the generator maximum output current is reached, or when an arc or overload condition occurs at the generator output.

6.1. Pin Assignment

The remote interface electrical connections are provided by a 25-pin subminiature D-type socket at the rear of the generator. The pins are numbered as shown below (viewed looking into socket on rear of generator):

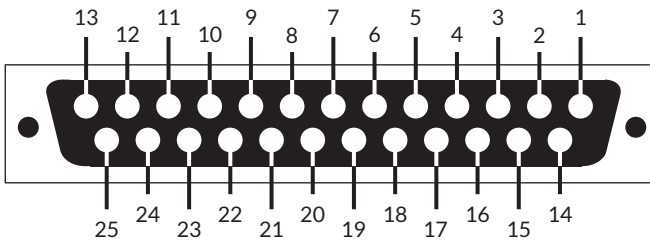

The corresponding 25-way D-type plug is Amphenol L717DB25P or equivalent. Any standard 25-way D-type connector, cable or breakout board can be used to make connections to the remote interface.

6. Remote Interface

The interface connections are as follows:

Pin No.	Function	Pin No.	Function
1	Remote on/off input +ve	14	Remote on/off input -ve
2	Remote current limit input	15	GND (0 V)
3	Remote voltage setpoint input	16	GND (0 V)
4	Remote voltage monitor output	17	GND (0 V)
5	Remote current monitor output	18	Remote voltage setpoint enable
6	+24 V reference output	19	GND (0 V)
7	+12 V reference output	20	GND (0 V)
8	Reserved	21	Reserved
9	Overload open collector	22	Overload open emitter
10	Operating open collector	23	Operating open emitter
11	Remote current limit enable	24	GND (0 V)
12	Not connected	25	Remote on/off enable
13	Not connected		

Pins that are identified as 'reserved' must be left disconnected and not 'tied' to any potential (e.g. ground, 24 V, etc.) These pins are used for production testing and are connected to internal circuitry within the generator.



Pins that are identified as 'not connected' can be connected to ground potential without damaging the generator.



6. Remote Interface

6.2. Electrical and Functional Characteristics

The remote interface functions and the electrical characteristics of the interface are described in detail below. The pins of the interface are grouped according to the function they provide.

The remote control functions (HV on/off, remote voltage setpoint, remote current limit) may be used in any combination. The remote monitoring functions are always active.



6.3. Remote On/Off Input (pins 1, 14, 24, 25)

The remote on/off input allows the high voltage output of the generator to be turned on or off by a voltage signal.

To use the remote on/off function, it must first be enabled by connecting pin 25 (remote on/off enable) to pin 24 (GND).

To turn the high voltage output on, a signal level of 10 - 30 V must be applied between pin 1 and pin 14 (pin 1 positive with respect to pin 14). This is a low impedance input, and will draw approximately 8 mA from the signal source at 10 V rising to 35 mA at 30 V.

The wiring example below shows how to connect an external HV on/off switch to the generator using the internal 12 V supply to provide the signal voltage.

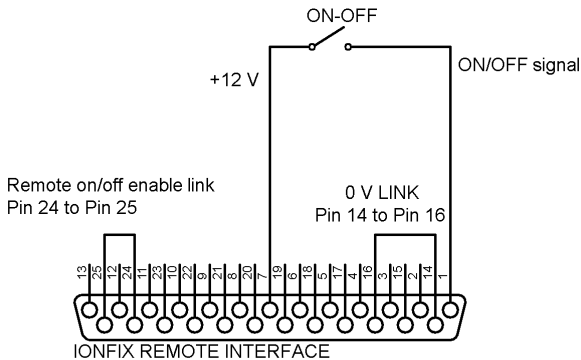

AS VIEWED LOOKING AT REAR OF GENERATOR

The front panel 'RUN/STOP' button may be used to momentarily override the remote on/off input for testing/commissioning purposes. The HV output of the generator will be enabled whilst the 'RUN/STOP' button remains pressed. It is not possible to turn the HV off using the 'RUN/STOP' button if it is enabled via the remote on/off input.

6. Remote Interface

6.4. Remote Voltage Setpoint Input (pins 3, 17, 18)

The Remote voltage setpoint input (pin 3) allows the high voltage output level of the generator to be programmed by an analogue voltage signal.

To use the remote voltage setpoint function, it must first be enabled by connecting pin 18 (external setpoint enable) to pin 17 (GND).

The Remote voltage setpoint input (pin 3) accepts a ground-referenced signal of 0 - 10 V, where 0 V represents 0% and 10 V represents 100% (i.e. 30 kV). The input impedance is 13 k Ω to GND.

The signal ground may be connected to any of the GND pins in the table – pin 15 or pin 16 are most convenient.

The input is protected against transient over-voltage but may be damaged by applying a low impedance voltage source exceeding 28 V.



The wiring example below shows the remote voltage setpoint function enabled and supplied by an external control voltage source (e.g. a PLC analogue output).

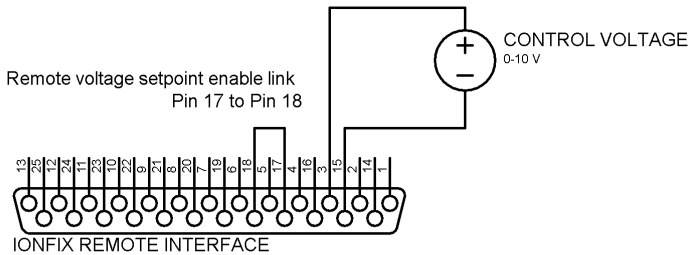

AS VIEWED LOOKING AT REAR OF GENERATOR

If the front panel voltage setpoint adjustment buttons are pressed when the Remote voltage setpoint function is enabled, an error message will be shown.



6. Remote Interface

6.5. Remote Current Limit Input (pins 2, 11, 20)

The Remote current limit input (pin 2) allows the output current limit of the generator to be programmed by an analogue voltage signal.

To use the remote current limit function, it must first be enabled by connecting pin 11 (Remote current limit enable) to pin 20 (GND).

The Remote current limit input (pin 2) accepts a ground-referenced signal of 0 - 10 V, where 0 V represents 0% and 10 V represents 100% (i.e. 1 mA). The input impedance is 13 k Ω to GND.

The signal ground may be connected to any of the GND pins in the table – pin 15 or pin 16 are most convenient.

The input is protected against transient over-voltage but may be damaged by applying a low impedance voltage source exceeding 28 V.

The wiring example below shows the remote current limit function enabled and supplied by an external control voltage source (e.g. a PLC analogue output).

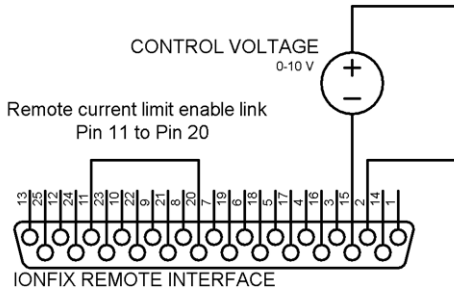

AS VIEWED LOOKING AT REAR OF GENERATOR

If the front panel current limit adjustment buttons are pressed when the remote current limit function is enabled, an error message will be shown.



6. Remote Interface

6.6. Remote Voltage Monitor Output (pin 4)

The remote voltage monitor output (pin 4) allows the present output voltage of the generator to be monitored remotely. This signal may be fed into a PLC system, or used to drive a panel meter (10 V fullscale sensitivity).

The voltage monitor output is always active, and always reports the actual measured output voltage of the generator. Note that if the current limit is active, the actual output voltage will be less than the demanded setpoint voltage (e.g. if the generator is heavily loaded).

The remote voltage monitor output provides a ground-referenced signal of 0 - 10 V, where 0 V represents 0% and 10 V represents 100% (i.e. 30 kV). Any of the GND pins may be used as a reference for this signal.

The voltage monitor output is protected against short circuit to GND, and applied voltages up to +28 V. The output impedance of the signal driver circuit is approximately 150 Ω .

The wiring example below shows a panel meter connected the remote voltage monitor output.

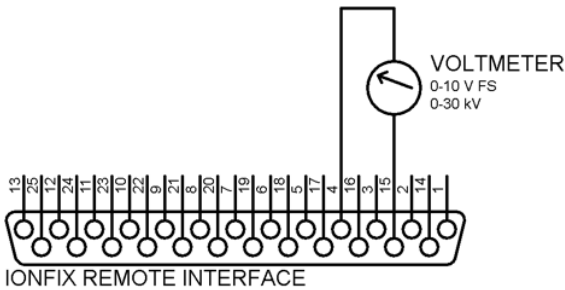

AS VIEWED LOOKING AT REAR OF GENERATOR

6. Remote Interface

6.7. Remote Current Monitor Output (pin 5)

The remote current monitor output (pin 5) allows the present output current of the generator to be monitored remotely. This signal may be fed into a PLC system, or used to drive a panel meter (10 V full-scale sensitivity).

The current monitor output is always active, and always reports the actual measured output current of the generator. Note that if the current limit is not active, the actual output current will be lower than the demanded current limit (e.g. if the generator is lightly loaded).

The remote current monitor output provides a ground-referenced signal of 0 - 10 V, where 0 V represents 0% and 10 V represents 100% (i.e. 1 mA). Any of the GND pins may be used as a reference for this signal.

The current monitor output is protected against short circuit to GND, and to voltages up to +28 V. The output impedance of the signal driver circuit is approximately 150 Ω .

The wiring example below shows a panel meter connected to the remote current monitor output.

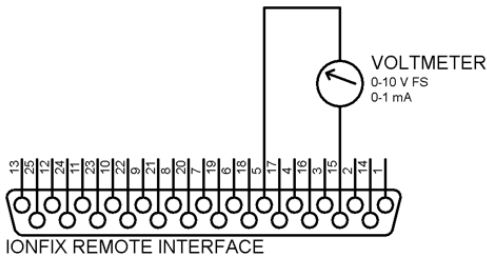

AS VIEWED LOOKING AT REAR OF GENERATOR

6. Remote Interface

6.8. Overload Output (pins 9, 22)

The overload output is activated when any of the following conditions are present:

- Output current limit reached (e.g. due to material not being present between charging and counter-electrodes).
- Load impedance less than 1.5 M Ω (overload condition including output short circuit).
- HV output arcing detected.

In the case of an overload or arc fault, the overload output will remain active whilst the generator HV output is disabled for a period of 4 seconds.

The overload output signals that a condition exists which is preventing the generator HV output level from reaching the demanded voltage setpoint.

This is an optically-isolated switching output, with the open collector on pin 9 and open emitter on pin 22. This output can switch up to 30 V with a load current of 50 mA in order to drive a relay, indicator, PLC input etc.

To provide a PLC-compatible signal, connect +24 V (supplied externally or from pin 6) to pin 9, and the PLC input to pin 22.

The wiring example below shows the overload output connected to a PLC system using an external power source to provide the 24 V signal level.

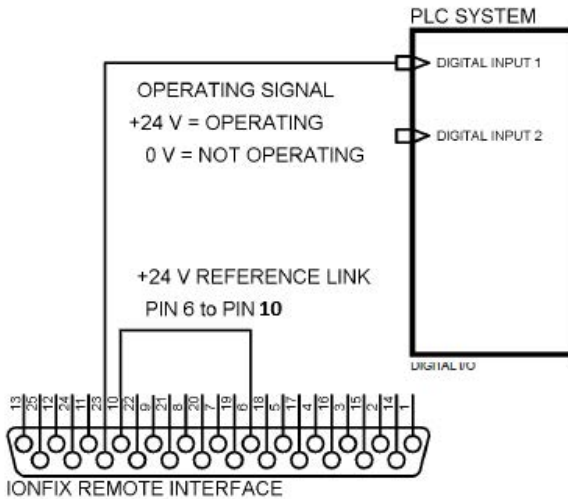

AS VIEWED LOOKING AT REAR OF GENERATOR

6. Remote Interface

6.9. Operating Output (pins 10, 23)

The operating output is activated when all of the following conditions are satisfied:

- HV output enabled via either the front panel run/stop button or the remote on/off input.
- Voltage setpoint not set to zero.
- Current limit not set to zero.
- No fault conditions present (input under-voltage, arc fault, over-temperature, etc.).

The operating output therefore signals that the generator is producing a high voltage output and is not experiencing any fault conditions.

This is detailed in the truth table below:

Remote on/off input 0: low (ENABLE = 0) 1: high (ENABLE = 1)	Front panel run/stop button 0: not pressed/toggled 1: pressed/toggled	Voltage setpoint & current limit 0: either = 0 1: neither = 0	Fault (any) 0: not present 1: present	Operating signal
0	0	0	0	INACTIVE
0	0	0	1	INACTIVE
0	0	1	0	INACTIVE
0	0	1	1	INACTIVE
0	1	0	0	INACTIVE
0	1	0	1	INACTIVE
0	1	1	0	ACTIVE
0	1	1	1	INACTIVE
1	0	0	0	INACTIVE
1	0	0	1	INACTIVE
1	0	1	0	ACTIVE
1	0	1	1	INACTIVE
1	1	0	0	INACTIVE
1	1	0	1	INACTIVE
1	1	1	0	ACTIVE
1	1	1	1	INACTIVE

6. Remote Interface

This is an optically-isolated switching output, with the open collector on pin 10 and open emitter on pin 23. This output can switch up to 30 V with a load current of 50 mA in order to drive a relay, indicator, PLC input etc.

To provide a PLC-compatible signal, connect +24 V (supplied externally or from pin 6) to pin 10, and the PLC input to pin 23.

The wiring example below shows the operating output connected to a PLC System, and uses an external 24 V DC Source connected to pin 10.

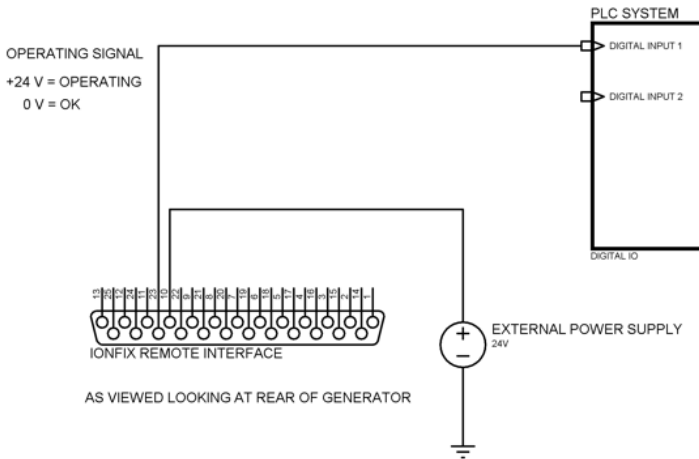

6.10. +24 V Reference Output (pin 6)

A 24 V reference output is supplied on pin 6 of the remote interface. This may be used to provide a signal for the overload and operating outputs. The maximum current that may be drawn from this output is 20 mA. This output is protected against overload and short-circuit.

6.11. +12 V Reference Output (pin 7)

A 12 V reference output is supplied on pin 7 of the remote interface. This may be used to provide a signal for the remote on/off input. The maximum current that may be drawn from this output is 20 mA. This output is protected against overload and short-circuit.

7. Technical Specifications

Power Supply Requirements: DC Variant	
Input voltage:	24 V DC nominal, 21 - 28 V operating range.
Input current:	2 A max.
Maximum input power:	48 W
Input connector:	<p>Combicon connector: Phoenix Contact 'Combicon' 2-pole pluggable terminal block. Mating plug type Phoenix Contact MSTB 2,5/ 2-STF, manufacturer P/N 1786831. Fraser P/N 730215.</p> <p>M12 connector: M12 male, 4-pole, flange mount. A coded. See section '11. Spares' for a range of connecting cables.</p>

Power Supply Requirements: AC Variant	
Input voltage:	90 - 250 V AC, 50/60 Hz
Input current:	1 A max.
Maximum input power:	74 W
Input connector:	IEC 60320 C14 inlet. Mating plug IEC 60320 C13.

Electrical Output Characteristics	
Output voltage:	0 – 30 kV, adjustable in 0.1 kV increments. 0 – 20 kV, adjustable in 0.1 kV increments for IML models.
Output polarity:	Fixed positive or negative, specified at time of order.
Output current limit:	1 mA max. up to 20 kV, reducing to 0.67 mA at 30 kV. Adjustable from zero to max. in 0.01 mA increments.
Maximum output power:	20 W, available from 20 kV to 30 kV. 20 kV limit for IML models.
Output voltage rise time:	<15 ms.
Output connector type:	4 x Fraser 30/60 kV tubular spring-contact HV connector.

Protection	
Short-circuit protection:	Continuous output current electronically limited.
Output arcing protection:	HV output disabled for 4 seconds in event of arcing.
Thermal protection:	HV output disabled if internal temperature exceeds safe limit.
Minimum load impedance:	1.5 M Ω – below this, output will be disabled.

7. Technical Specifications

Remote Interface	
Connector type:	25-pin subminiature D-type, female. Mating plug Amphenol L717DB25P or equivalent.
Remote control functions:	HV on/off (digital, 10 - 30 V 'on', 10 - 25 mA input current). Voltage setpoint adjust (analogue, 0 - 10 V = 0 - 100 %). Current limit adjust (analogue, 0 - 10 V = 0 - 100 %).
Remote monitoring functions:	Overload signal. Open collector/emitter outputs, 50 V/50 mA maximum load. Operating signal. Open collector/emitter outputs, 50 V/50 mA maximum load. Remote voltage monitor (analogue, 0 - 10 V = 0 - 100 %). Remote current monitor (analogue, 0 - 10 V = 0 - 100 %).
Auxiliary power supply:	12 V, 20 mA. May be used to drive remote on/off input.

Environmental Conditions	
Ambient temperature:	0 - 50 °C
Relative humidity:	Maximum 70%, non-condensing. Tested to IEC 60068-2-30:2005 (Damp heat, cyclic), 55 °C, 6 cycles.
Ingress protection:	IP20 (must not be exposed to falling, splashing or spraying water).
Vibration:	Installation location must be vibration-free.

Mechanical	
Dimensions (W x H x D):	158.30 mm x 105.25 mm x 277 mm
Mass (AC variant):	4.6 kg

Regulatory	
CE Marking:	EU LVD (2014/35/EU) EU EMCD (2014/30/EU) Emissions: EN 61000-6-3:2007 Immunity: EN 61000-6-2:2005 Harmonics: EN 61000-3-2:2006+A2:2009
Approvals:	IEC CB Certificate: DK-94020-UL UL Certified File No. E313877

Options	
No-cost options:	Display orientation ('desktop' or 'wall-mount').

7. Technical Specifications

Dimensions

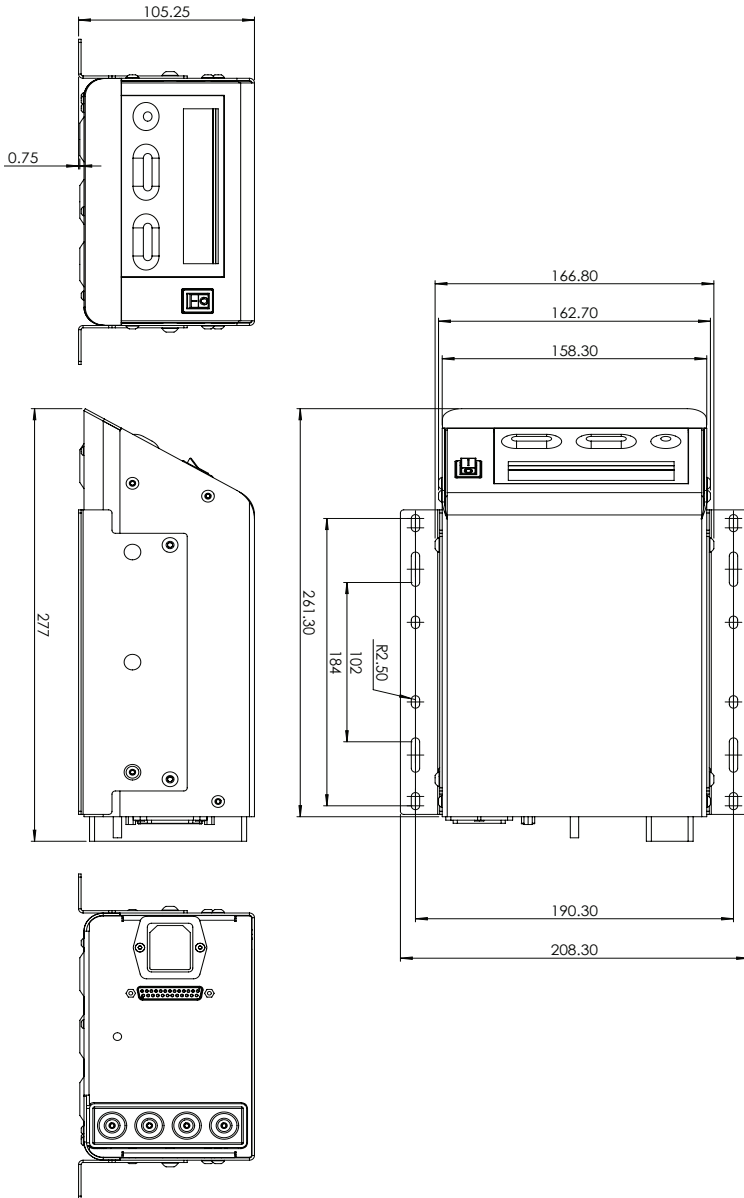

8. Troubleshooting

In case of problems with the generator, consult the following table to aid diagnosis and remedy.

Problem	Cause	Remedy
No output voltage Display off	Power supply not connected or energised.	Check power supply connections.
	AC variant: inlet fuse blown.	Replace fuse.
	Hardware fault.	Contact distributor.
No output voltage Display on	Voltage setpoint not changed from default 0.0 kV or remote setpoint not provided.	Change setpoint using Voltage +/- buttons or provide 0 - 10 V signal on remote interface.
	Remote on/off enabled, but no remote on/off signal provided.	Provide remote on/off signal.
	Current limit set too low.	Increase current limit using Current +/- buttons.
All LEDs flashing 'OVERLOAD' shown on display	Arcing or short-circuit on HV output due to electrode or cable fault.	Check and rectify electrode or cable faults.
	Generator overloaded.	Move charging electrode(s) further from counter-electrode.
All LEDs flashing 'OVER TEMP' shown on display	Generator internal temperature too high.	Move generator to cooler location. Reduce loading on generator.
All LEDs flashing 'UNDER VOLTAGE' shown on display	Supply voltage too low (<21 V).	Check supply voltage.
All LEDs flashing 'OVER VOLTAGE' shown on display	Supply voltage too high (>28 V).	Check supply voltage.
All LEDs flashing Any other message shown on display	Internal fault with generator.	Contact distributor.

9. Maintenance and Repair

9.1. Maintenance

Keep the generator dry and free of dust, dirt, corrosive substances and solvents. Avoid touching the plastic barrel of the high voltage connectors when connecting or disconnecting charging electrodes.

Regularly check the earthing of the generator to ensure continued safety and correct operation.

Regularly inspect the high-voltage connectors and cables for mechanical or electrical damage.

There are no parts requiring periodic maintenance within the generator.

Do not use alcohol or solvent-based products to clean the high-voltage sockets on the generator.



9.2. Repairs

In the event of a fault with the generator which cannot be rectified by following the steps detailed in 'troubleshooting', contact your Fraser distributor in the first instance.

The generator has been designed to allow the major internal components to be easily replaced. This must only be carried out by suitably qualified and trained persons, and using genuine replacement parts supplied by Fraser Anti-Static Techniques.

In some cases it may be necessary for the generator to be returned to Fraser Anti-Static Techniques for investigation and repair. Please ensure the generator is suitably packaged and clearly indicate the symptoms of the fault encountered, including any error messages displayed by the generator.

10. Disposal

Dispose of the generator in accordance with local environmental regulations pertaining to electrical waste.

11. Spare Parts

The following spare parts are available for the IONFIX Compact Generator.

Part No.	Description
73021	Spare 60 kV Ionfix Connection
7301522	Remote Monitoring & Control Interface Connector
80895	Fuse: 1A, 250 V AC, T (5 x 20 mm)
730218	Blanking plug for HV socket
730215	Combicon input plug for DC variant
80779	M12 x 4-pin, 24 V Power Cable - 5 m.

This page intentionally blank

This page intentionally blank

For more information about static and to view the full range
of our products, please visit www.fraser-antistatic.com



Scotts Business Park, Bampton, Devon, EX16 9DN, UK
T + 44 (0) 1398 331114 F + 44 (0) 1398 331411
E sales@fraser-antistatic.co.uk W www.fraser-antistatic.com