



---

**IONFIX PRO**  
WITH REMOTE MONITORING AND CONTROL INTERFACE





Fraser static control equipment has been designed to give you many years of productive service. However, the science of static control has unique rules which must be followed to allow the equipment to give a good return on your investment.



Please read the following operating and maintenance instructions carefully.

<b>Section</b>		<b>Page</b>
1	Introduction	4
2	Safety	5
3	Use and Operation	6
4	Installation	7
5	Commissioning and Operation	10
6	Generator Configuration Menu	16
7	Advanced Settings Menu	18
8	System Information Menu	22
9	Fault Count Menu	23
10	Remote Interface	24
11	Technical Specifications	38
12	Troubleshooting	42
13	Maintenance and Repair	43
14	Disposal	44
15	Spare Parts	44

---

## 1. Introduction

---

This manual applies to the Fraser IONFIX PRO Generator product range:

- IONFIX PRO, 90 - 250 V AC input, 30 kV DC output, positive or negative output polarity.
- IONFIX PRO, 90 - 250 V AC input, 60 kV DC output, positive or negative output polarity.

It is essential that you read and understand the complete manual before installing and using this equipment. This is important for both safety and warranty cover.

Where the word 'generator' is used within this manual, it refers exclusively to the Fraser IONFIX PRO Generator.

### 1.1. Explanation of Symbols

Throughout this manual the following symbols are used to draw attention to important information.

**Warning:** This symbol refers to operations which, if carried out improperly, may result in serious personal injuries.



**Caution:** This symbol refers to operations which, if carried out improperly, may result in damage to property.



**Information:** This symbol refers to information which relates to obtaining the best performance and operating life from the product.



---

## 2. Safety

---

### 2.1. Safety Concepts

The Fraser IONFIX PRO is a high-voltage switched-mode power supply. It has been designed in accordance with the safety requirements of the EU Low Voltage Directive.

The user-accessible remote interfacing circuits of the generator are galvanically isolated from mains voltages.

The high-voltage output of the generator is a Class 2 electrical energy source, which mean it is capable of causing pain if contact is made with a body part, but is not likely to cause an injury requiring medical attention.

The dimensions of the industry-standard high-voltage output connectors are such that they may not be considered to provide insulation between a body part and the outer surface of the connector.

The generator must therefore be used only by instructed persons. An instructed person is someone who is instructed or supervised by a skilled person with regard to hazards posed by electrical energy sources.

If the generator is to be operated by ordinary persons, it must be installed in such a manner that the high voltage output connectors are not accessible in normal operation, for example by mounting within an enclosure or providing appropriate guards.

### 2.2. Safety Warnings

- Installation and maintenance work on the generator must only be carried out by suitably qualified personnel.
- The protective earthing (PE) terminal of the generator must be permanently connected to the main earthing terminal of the electrical installation by a conductor of at least 0.5 mm<sup>2</sup> cross-sectional area.
- Disconnect the power supply before performing any installation and maintenance work on the generator or charging electrode(s).
- Connect only approved charging accessories to the high voltage outputs of the generator.
- Avoid contact with the high-voltage output connector and the charging electrode(s) when energised.
- Do not insert or remove high voltage connectors when the generator is powered or its output energised.
- Any changes to the equipment without written consent of the manufacturer will invalidate the warranty and CE certification.



---

### 3. Use and Operation

---

The Fraser IONFIX PRO is a controlled high-voltage power supply designed to power charging electrodes providing temporary adhesion between materials in industrial applications.

The IONFIX PRO has simple front-panel controls allowing the output voltage to be set precisely to match the process requirements. The output current is electronically limited, and this limit may be adjusted if necessary to suit the particular application.

The IONFIX PRO has a fully featured remote interface, providing remote switching of the high-voltage output and remote setting of the output voltage and current. The operating status and output parameters of the generator are signalled on this interface, allowing remote monitoring of the generator and process.

#### 3.1. Overview

The diagram below shows the main features of the IONFIX PRO generator:

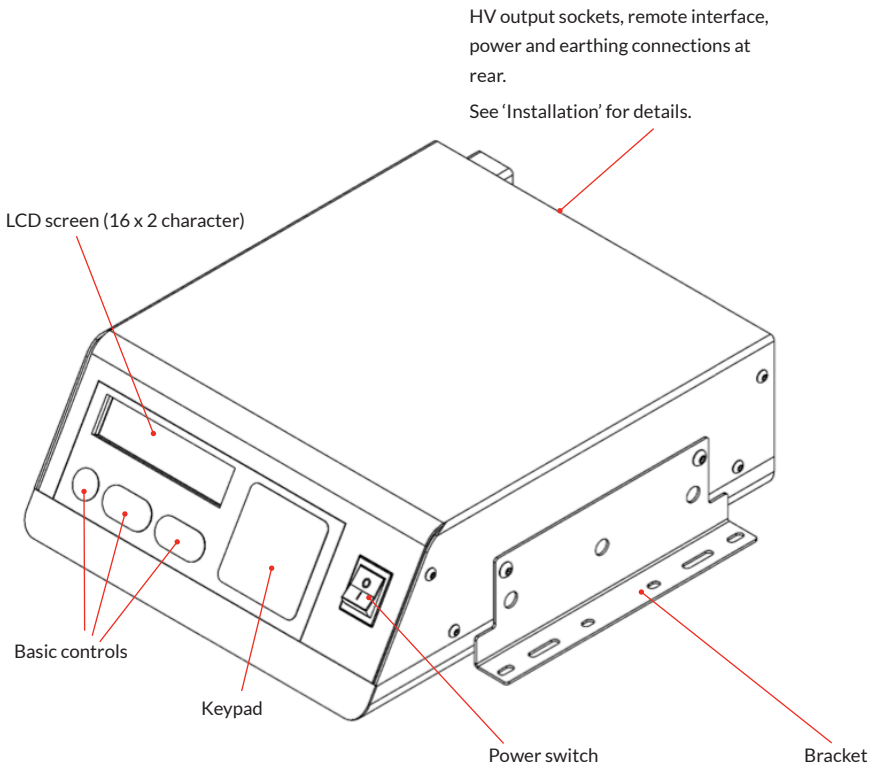

---

## 4. Installation

---

### 4.1. Checking on delivered equipment

The equipment leaves our factory in suitable protective packaging. Please check that it is undamaged when it arrives.

If there is visible damage, contact the supplier immediately.

Check that the parts which have been delivered are the same as you have ordered.

### 4.2. Front panel rotation

The front panel display and controls of the generator may be rotated by 180° to accommodate different mounting orientations. Display orientation may be specified at time of order.

**Warning:** The IONFIX PRO contains potentially lethal voltages. Disconnect the mains supply and wait 5 minutes for stored energy to be automatically discharged before removing the lid.



To rotate the display from 'desktop' to 'wall-mounted' orientation, follow the steps below:

1. Ensure the generator is switched off and disconnected from its power supply.
2. Remove the 8 M4x8 mm screws securing the lid of the generator using a 3 mm hex key or driver.
3. Remove the 3 M3 screws securing the front panel assembly to the generator chassis (underneath the generator).
4. Undo the 6 M3x15 mm threaded spacers securing the display and control assembly to the generator front panel, using a 5.5 mm spanner.
5. Rotate the display and control assembly by 180°. Ensure that the flexible cable connecting the display and controls to the main PCB does not become trapped, kinked or unseated from its connections.
6. Secure the display and control assembly in its new orientation, then re-fit the front panel assembly to the generator chassis.
7. Replace the lid and secure using the 8 M4 screws.

---

## 4. Installation

---

### 4.3. Mounting

The generator is provided with mounting brackets to allow mounting to a wall or panel, under a table or shelf, etc. Use only the hardware provided (M5x10 mm) to affix the mounting brackets to the generator.

If wall-mounted, use fixings suitable for the wall material and generator weight to secure the generator. Ensure that the generator is securely mounted and that all mounting fasteners have been tightened before use.

If insufficient free air circulation space is provided around the generator and it is heavily loaded in high ambient temperature conditions, the built-in thermal overload protection may be activated. Relocate the generator or reduce loading in this case.



### 4.4. Earthing

The M5 protective earthing (PE) terminal of the generator **MUST** be permanently connected to the main earthing terminal of the electrical installation by a conductor of at least 0.5 mm<sup>2</sup> cross-sectional area (20 AWG). A suitable cable assembly is provided with the generator.

An earthed IEC 320 C13 cable **MUST** be used with the generator, and the socket outlet supplying the generator **MUST** be earthed correctly.



---

## 4. Installation

---

### 4.5. Electrical installation

This section describes the electrical installation of the generator. The electrical connections are shown below.

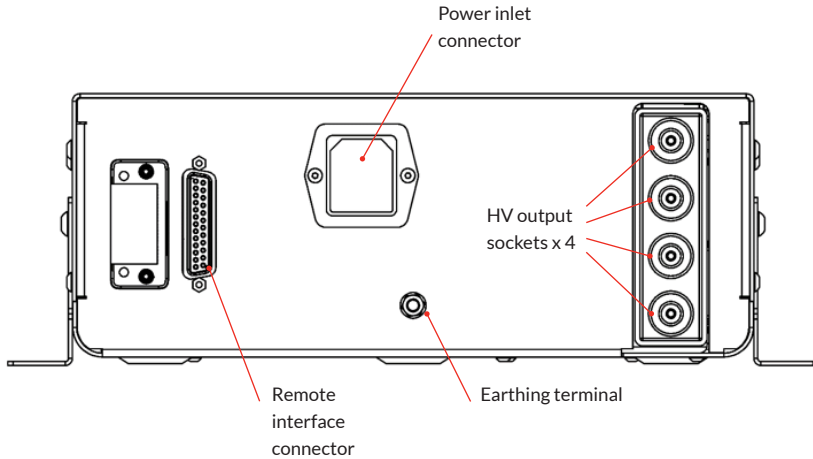

1. Ensure that the generator is earthed as described above.
2. Connect the charging electrode(s) to the HV output sockets at the rear of the generator. The 4 sockets are internally connected in parallel. Ensure that any unused sockets are plugged with the supplied blanking plugs - (Fraser Part No. 730218) - to prevent dirt ingress.
  - Do not route HV cables near to sharp metal components.
  - Avoid bends or kinks in the HV cables.
  - Route HV cables separately from low-voltage cables.
  - Keep HV cables as short as practically possible.
3. If using the remote interface, connect the cable to the 25-way, D-type connector at the rear of the generator. For details, see 'Remote Interface' section of this manual.
4. Connect the power input cable to the generator and connect it to the mains supply.



---

## 5. Commissioning and Operation

---

For advice about tuning the generator settings to best suit a particular process, please contact your local Fraser representative.

Before turning the generator on for the first time, ensure that:

- The power input and case are correctly grounded as described in 'Electrical Installation'.
- The charging electrodes are correctly connected to the output sockets, with no loose connections or damaged cables.
- Any wiring connected to the remote interface is configured correctly. If the remote interface is configured to override the front panel controls, ensure that the charging electrodes becoming energised does not pose a safety risk.
- The generator is securely mounted.



### 5.1. Generator front panel controls and display

The diagram below shows the front panel controls and display of the generator. The function of the controls is described in brief below the diagram.

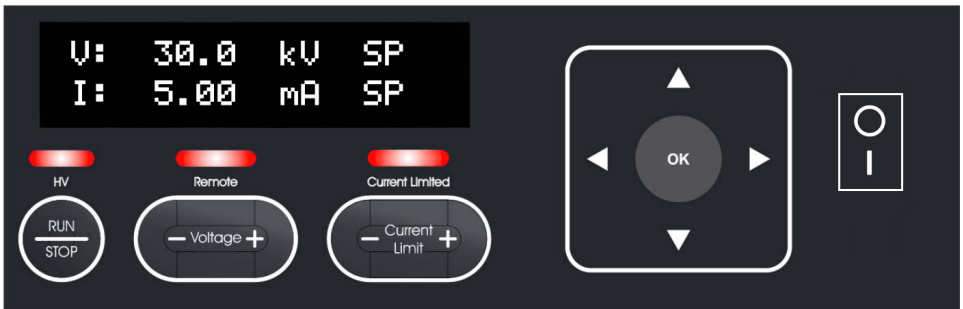

- **Display:** Indicates the settings and output parameters of the generator, displays the generator configuration menu and any warning messages.
- **LED Indicators (HV, Remote, Current Limited):** Show the operating status of the generator at a glance.
- **RUN/STOP Button:** Toggles the high voltage output of the generator on and off.
- **Voltage +/- Buttons:** Allow the high voltage output level of the generator to be adjusted.
- **Current Limit +/- Buttons:** Allow the output current limit level of the generator to be adjusted.
- **4-way keypad and OK Button:** Used to access the generator configuration menu and change parameters.

---

## 5. Commissioning and Operation

---

### 5.2. Switching the generator on

To power up the generator, put the main power switch on the front panel into the 'ON' position.

The LCD backlight will illuminate and the following text will be displayed on the screen as the generator initialises and performs self-checks (30 kV positive variant shown):

```
Fraser IONFIX+30
Startup = V: xxx
```

Note: 'V: xxx' is the software level of the generator.

The LCD will then switch to the normal operating display (positive 30 kV generator shown):

```
V:      0.0 kV      SP
I:      5.00 mA     SP
```

If any of the generator remote interface functions are enabled the 'Remote' LED indicator will illuminate. Note that in this case, the HV output of the generator may be enabled remotely at any time.

If the remote on/off function is not enabled, the generator HV output will always be OFF when the generator is powered up. If it is necessary for the generator to power up with the HV output enabled, use the remote on/off function to achieve this.

When the generator mains power is switched off, an 'UNDER VOLTAGE' fault message will be displayed as internal stored energy is dissipated. This is normal and does not indicate a problem with the unit.



---

## 5. Commissioning and Operation

---

### 5.3. Setting output voltage

When the HV output is not enabled, the generator voltage and current setpoint values are shown on the display, along with 'SP' to indicate that these are setpoint values.

By default, the generator output voltage is initially set to 0.0 kV. The setpoint value is stored in non-volatile memory and does not need to be re-set every time the generator is powered on.

To adjust the generator output voltage setpoint, use the 'Voltage +' and 'Voltage -' buttons. For example, if the voltage setpoint was increased to 22.5 kV, the following would be displayed:

```
U:    22.5 kV    SP
I:    5.00 mA    SP
```

Press the appropriate button once to increase or decrease the voltage in 0.1 kV steps. Press and hold the appropriate button to make larger adjustments.

On negative polarity generators, the 'Voltage +' button increases the magnitude of the voltage setpoint, making it more negative. This corresponds to a stronger charging effect at the connected electrode(s).

If the voltage setpoint is adjusted whilst the HV output is enabled, the setpoint values followed by 'SP' will be shown briefly on the display.



---

## 5. Commissioning and Operation

---

### 5.4. Setting output current limit

The output current of the generator is electronically limited to protect the generator and minimise electrode wear. The current limit level can be adjusted using the front-panel controls. By default, the generator current limit is set to its maximum value: 5 mA (30 kV variant) or 2.5 mA (60 kV variant).

When the current limit is active, the 'Current Limited' LED indicator will illuminate.



To adjust the current limit, use the 'Current -' and 'Current +' to change the setpoint value. For example, if the current setpoint was reduced to 3.5 mA, the following would be displayed:

```
V:    22.5 kV    SP
I:    3.50 mA    SP
```

If the current limit is adjusted whilst the HV output is enabled, the setpoint values followed by 'SP' will be shown briefly on the display.



### 5.5. Switching high voltage on/off

To enable the high voltage output of the generator, press the 'RUN/STOP' button. The 'HV' indicator LED will illuminate to signal that the High Voltage output is active, and 'SP' will be replaced with 'OP' on the LCD. This indicates that the displayed values are the present measured outputs.

```
V:    22.5 kV    OP
I:    0.81 mA    OP
```

If the remote on/off function is not enabled, the RUN/STOP button toggles the high voltage output on and off.

If the remote on/off function is enabled, but the HV output is not turned on via the remote interface, the RUN/STOP button can be used to temporarily override the remote on/off input for testing or commissioning purposes. When the button is released, the HV output will be turned off. If the HV output is already turned on via the remote interface, the RUN/STOP button will have no effect.

---

## 5. Commissioning and Operation

---

### 5.6. Operation with remote interface active

This section describes the operation of the front panel display and controls when the remote interface is in use. For details of the remote interface, see the 'Remote Interface' section of this manual.

### 5.7. 'REMOTE' LED indicator

If any of the remote control functions (remote on/off, remote voltage setpoint, remote current limit) are enabled via the menu, the 'REMOTE' LED indicator on the generator front panel will illuminate.

If the remote on/off function is enabled, the HV output of the generator could be enabled at any time via a remote signal.



### 5.8. Remote on/off input

If the remote on/off input is enabled, the 'REMOTE' LED indicator will illuminate as described above. When the HV output is enabled using the remote on/off input, the 'HV' indicator will illuminate.

### 5.9. Remote voltage setpoint

If the remote voltage setpoint function is enabled, an 'R' will be added to the 'SP' or 'OP' after the voltage readout on the generator display.

For example, with HV off and remote voltage setpoint enabled:

```
U:   17.2 kV   RSP
I:   0.50 mA   SP
```

With HV on and remote voltage setpoint enabled:

```
U:   17.2 kV   ROP
I:   0.16 mA   OP
```

If the front panel voltage adjustment buttons are pressed in this state, the following message will be shown and the setpoint will not be adjusted:

```
REMOTE VOLTAGE
SETPOINT ACTIVE!
```

---

## 5. Commissioning and Operation

---

### 5.10. Remote current limit

If the remote current limit function is enabled, an 'R' will be added to the 'SP' or 'OP' after the current readout on the generator display.

For example, with HV off and remote current limit enabled:

```
U: 14.5 kV SP
I: 0.32 mA RSP
```

With HV on and remote current limit enabled:

```
U: 10.1 kV OP
I: 0.32 mA ROP
```

If the front panel current limit adjustment buttons are pressed in this state, the following message will be shown and the setpoint will not be adjusted:

```
REMOTE CURRENT
SETPOINT ACTIVE!
```

If both the remote voltage setpoint and remote current limit are enabled, the following will be shown (HV off):

```
U: 17.2 kV RSP
I: 0.32 mA RSP
```

HV on:

```
U: 14.3 kV ROP
I: 0.32 mA ROP
```

---

## 6. Generator Configuration Menu

---

The generator configuration menu allows various aspects of the generator operation to be adjusted and configured, and provides diagnostic information about the generator and its operating parameters.

There are four (4) pages in the menu system:

1. **Remote Mode** – allows the generator remote interface to be enabled and configured.
  - See 'Remote Interface' section for details.
2. **Advanced Settings** – allows various aspects of generator operation to be adjusted.
  - See 'Advanced Settings Menu' below for details.
3. **System Information** – provides diagnostic information about the generator.
  - See 'System Information Menu' below for details.
4. **Fault Counters** – provides further diagnostic information.
  - See 'Fault Counter Menu' below for details.

### 6.1. Using the menu system

The generator configuration menu is accessed using the 4-way keypad and 'OK' button to the right of the LCD screen. The key functions are as follows:

- **Right (▶)**: Move down to a lower menu level, access parameter for adjustment.
- **Left (◀)**: Move up to a higher menu level, exit menu system.
- **Up (▲)**: Move up a list of menu items, increase parameter value.
- **Down (▼)**: Move down a list of menu items, decrease parameter value.
- **OK**: Move down to a lower menu level, save setting.

Pressing any of the setpoint adjustment buttons (Voltage +/-, Current +/-) while using the menu will exit the menu system.

For example, to navigate to menu item 2.1 (LCD contrast adjustment) and change its value, the following sequence of key-presses is required.

## 6. Generator Configuration Menu

Key	Function	Generator Display (after key pressed)
N/A	Starting point.	U: 0.0 kV SP I: 5.00 mA SP
▶	Enter menu system.	[MAIN] 1 Remote Mode
▼	Scroll through list of menu pages	[MAIN] 2 Advanced Set
▶	Enter menu page.	Advanced Set 1 Contrast
▶	Select parameter for adjustment.	Contrast 6
▲	Increase parameter value.	Contrast 7
▲	Increase parameter value again.	Contrast 8
OK	Save parameter value.	Advanced Set 1 Contrast
◀	Return to main menu.	[MAIN] 2 Advanced Set
◀	Exit menu system.	U: 0.0 kV SP I: 5.00 mA SP

---

## 7. Advanced Settings Menu

---

The advanced settings menu (menu page 2) allows various aspects of generator operation to be adjusted.

Item	Name	Description	Default Value	Parameter Range
2.1	Contrast	Allows LCD screen contrast to be adjusted for maximum visibility.	6	0 – 30.

The display contrast is checked at the factory and this setting adjusted if necessary. If the positioning of the generator makes the screen difficult to read, or to compensate for changes in the screen over time, adjust this setting until best visibility is obtained (see example above).

Item	Name	Description	Default Value	Parameter Range
2.2	Lock	Locks front panel controls to prevent adjustment of setpoint values.	OFF	ON/OFF

When the controls are locked, no local adjustments can be made by the user. This feature may be used to prevent unauthorised or accidental changes to process settings following commissioning. Remote interface operation is not affected by locking the generator.

To lock the generator, navigate to item 2 in the advanced settings menu and follow the sequence of operations shown below (navigation through menu not shown).

## 7. Advanced Settings Menu

Key	Function	Generator Display (after key pressed)
N/A	Starting point.	Advanced Set 2 Lock
▶	Select parameter for adjustment.	Lock Off
▲	Set parameter to 'On'.	Lock On
OK	Save parameter value (lock generator).	V: 0.0 kV SP I: 5.00 mA SP

The generator is now locked.

If any of the controls are pressed when locked, the following message will be displayed:

**GENERATOR LOCKED**  
0

To unlock the keypad, enter the following sequence on the 4-way keypad:

▲,▲,▼,▼,◀,▶,◀,▶.

As this sequence is entered, the numeric value on the screen will increment with each correct key press. After the last ▶ is entered, the generator will unlock.

If the sequence is entered incorrectly, the generator will return to the normal operating display and another attempt can be made to unlock the generator immediately.

## 7. Advanced Settings Menu

Item	Name	Description	Default Value	Parameter Range
2.3	Factory Reset	Return all parameters to factory defaults.	N/A	N/A

This menu item allows all generator settings to be returned to their factory defaults. If the remote interface is in use, it will need to be re-enabled and configured using menu page 1. See 'Remote Interface' section for details.

To reset the generator to factory defaults, navigate to item 3 in the advanced settings menu and follow the sequence of operations shown below (navigation through menu not shown).

Key	Function	Generator Display (after key pressed)
N/A	Starting point.	Advanced Set 3 Factory Reset
▶	Select parameter for adjustment.	Factory Reset Off
▲	Set parameter to 'On'.	Factory Reset On
OK	Save parameter value (reset generator).	Fraser IONFIX+30 Startup = U: xxx

The generator will re-initialise and return to the normal operating display with default setpoint values loaded.

---

## 8. System Information Menu

---

The system information menu (menu page 3) provides information about the generator. The parameters in this menu are read-only and cannot be adjusted. These parameters may be useful if requesting support for an IONFIX generator from the factory.

To view a parameter value, follow the sequence of operations shown below (navigation through menu not shown, internal temperature used as example).

Key	Function	Generator Display (after key pressed)
N/A	Starting point.	System Info 1 Serial
▼	Scroll through menu items.	System Info 2 Board
▼	Scroll through menu items.	System Info 3 Temp
▶	Select parameter to view.	Temp 30
◀	Return to menu.	Advanced Set 3 Factory Reset
◀	Return to main menu.	Advanced Set 3 Factory Reset
◀	Exit menu system.	U: 0.0 kV SP I: 5.00 mA SP

---

## 8. System Information Menu

---

Item	Name	Description	Details
3.1	<b>Serial</b>	Unit serial number.	Set at factory.
3.2	<b>Board</b>	Control PCB serial number.	Set at factory.
3.3	<b>Temp</b>	Unit internal temperature.	Units of °C, updated continuously.
3.4	<b>Operate Time</b>	Total HV operation time.	Units of minutes, updated every 30 minutes.
3.5	<b>Running Time</b>	Total powered time.	Units of minutes, updated every 30 minutes.
3.6	<b>Type</b>	Generator model type.	Voltage, polarity e.g. 'IONFIX+30' for positive 30 kV.
3.7	<b>Software Ver</b>	Generator firmware release number and build reference.	E.g. 150:13870
3.8	<b>Boot Counter</b>	Number of times unit has been powered up and/or reset.	Not cleared on factory reset.
3.9	<b>About</b>	Information message.	Information message.

---

## 9. Fault Count Menu

---

### Fault count menu

The fault count menu (menu page 4) provides information about how many fault events (e.g. output overload, over temperature, etc.) the generator has detected. The parameters in this menu are read-only and cannot be adjusted. These parameters may be useful if requesting support for an IONFIX generator from the factory.

Navigation of this menu is performed in the same way as for the system information menu. All parameters are stored in non-volatile memory and are retained when a factory reset is performed.

Item	Name	Description	Details
4.1	<b>Overload/Arc</b>	Number of overload/arc events detected by generator.	Indicative of damaged HV cable or charging electrode.
4.2	<b>Over input V</b>	Number of input over-voltage events detected by generator.	Indicative of excessively high mains supply voltage.
4.3	<b>Under input V</b>	Number of input under-voltage events detected by generator.	Does not include normal power off 'undervoltage' warnings – only increments when voltage returns to normal range.
4.4	<b>Over temp</b>	Number of internal over-temperature events detected by generator.	Indicative of excessive ambient temperature or poor airflow around unit.
4.5	<b>Sense OOR</b>	Number of voltage/current sense out of range events detected by generator.	Indicative of hardware fault or presence of electrical interference.
4.6	<b>No HVM</b>	Number of 'no high voltage module connected' events detected by generator.	Indicative of hardware fault.
4.7	<b>Incorrect HVM</b>	Number of 'incorrect high voltage module connected' events detected by generator.	Indicative of hardware fault.
4.8	<b>Over I Prog</b>	Number of overcurrent events detected on remote setpoint inputs when in 0-20/4-20 mA current loop mode.	Indicative of installation issues (remote interface mis-wiring).

---

## 10. Remote Interface

---

The generator is equipped with a remote control and monitoring interface permitting remote setting and operation of the generator.

The following functions are provided:

- Remote on/off input: permits the HV output of the generator to be switched on or off using a voltage signal.
- Remote voltage setpoint input: permits the HV output of the generator to be controlled from 0 - 100% according to an analogue voltage or current signal, e.g. from a PLC output.
- Remote current setpoint input: permits the output current limit of the generator to be controlled from 0 - 100% according to an analogue voltage or current signal.
- Remote voltage monitor output: permits the actual HV output level to be monitored remotely as an analogue voltage or current signal.
- Remote current monitor output: permits the actual output (charging) current to be monitored remotely as an analogue voltage or current signal.
- Operating signal output: signals when the generator is operating normally.
- Overload/limit signal output: signals when the generator maximum output current is reached, or when an arc or overload condition occurs at the generator output.

The operation of the remote interface is configured using the 'Remote Mode' menu (page 1 of the configuration menu structure).

See section 'using the menu system' for details of how to navigate the menu structure and set parameter values.

---

## 10. Remote Interface

---

### 10.1. Pin assignment

The remote interface electrical connections are provided by a 25-pin subminiature D-type socket at the rear of the generator. The pins are numbered as shown below (viewed looking into socket on rear of generator):

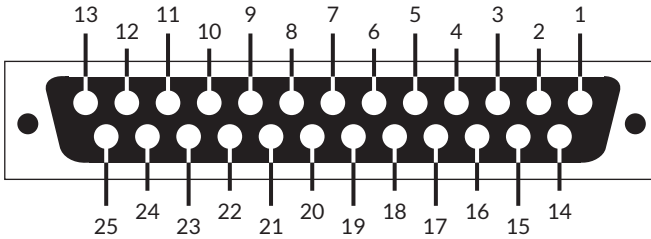

The corresponding 25-way D-type plug is Amphenol L717DB25P or equivalent.

Any standard 25-way D-type connector, cable or breakout board can be used to make connections to the remote interface.



---

## 10. Remote Interface

---

The interface connections are as follows:

Pin No.	Function	Pin No.	Function
1	Remote on/off input +ve	14	Remote on/off input -ve
2	Remote current setpoint input	15	GND (0 V)
3	Remote voltage setpoint input	16	GND (0 V)
4	Remote voltage monitor output	17	GND (0 V)
5	Remote current monitor output	18	Reserved
6	Reserved	19	GND (0 V)
7	+12 V reference output	20	GND (0 V)
8	Reserved	21	Reserved
9	Arc/Limit open collector	22	Arc/Limit open emitter
10	Operating open collector	23	Operating open emitter
11	Reserved	24	GND (0 V)
12	Not connected	25	Reserved
13	Not connected		

Pins which are identified as 'reserved' should be left disconnected and not 'tied' to any potential (e.g. ground, 24 V, etc.) These pins are used for production testing or other product variants and are connected to internal circuitry within the generator.



Pins which are identified as 'not connected' can be connected to ground potential without damaging the generator.



### 10.2. Electrical and functional characteristics

The remote interface functions and the electrical characteristics of the interface are described in detail below. The pins of the interface are grouped according to the function they provide.

The remote control functions (HV on/off, remote voltage setpoint, remote current limit) may be used in any combination. The remote monitoring functions are always active.



---

## 10. Remote Interface

---

### 10.3. Remote on/off input (pins 1, 14)

The remote on/off input allows the high voltage output of the generator to be turned on or off by a voltage signal.

To use the remote on/off function, it must first be enabled in the generator configuration menu.

Item	Name	Description	Default Value	Parameter Range
1.1	Remote En	Enable/disable remote on/off input.	OFF	ON/OFF

To turn the high voltage output on, a signal level of 10 - 30 V must be applied between pin 1 and pin 14 (pin 1 positive with respect to pin 14). This is a low impedance input, and will draw approximately 8 mA from the signal source at 10 V rising to 35 mA at 30 V.

The wiring example below shows how to connect an external HV on/off switch to the generator using the internal 12 V supply to provide the signal voltage.

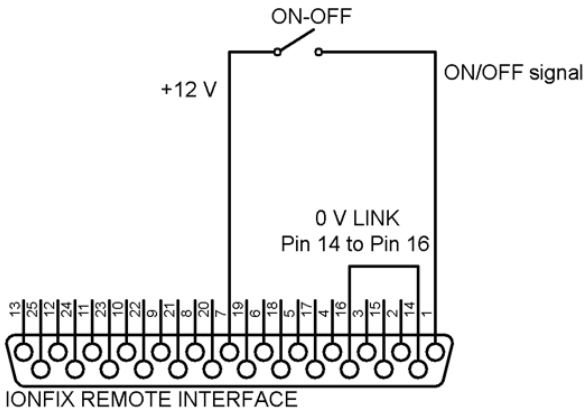

AS VIEWED LOOKING AT REAR OF GENERATOR

The front panel 'RUN/STOP' button may be used to momentarily over-ride the remote on/off input for testing/commissioning purposes. The HV output of the generator will be enabled whilst the 'RUN/STOP' button remains pressed. It is not possible to turn the HV off using the 'RUN/STOP' button if it is enabled via the remote on/off input.

---

## 10. Remote Interface

---

### 10.4. Remote voltage setpoint input (pin 3)

The remote voltage setpoint input (pin 3) allows the high voltage output level of the generator to be programmed by an external analogue voltage or current signal.

To use the remote voltage setpoint function, it must first be enabled in the generator configuration menu by setting parameter 1.2 to 'ON'.

Item	Name	Description	Default Value	Parameter Range
1.2	Remote VSp	Enable/disable remote voltage setpoint.	OFF	ON/OFF

The remote voltage setpoint input (pin 3) can be configured to accept 4 different signal types via the remote mode menu.

Item	Name	Description	Default Value	Parameter Range
1.4	Vprog Mode	Change voltage setpoint input mode.	0-10 V	0-10 V 0-20 mA 0-5 V 4-20 mA

The input signal must be ground-referenced. The signal ground may be connected to any of the GND pins in the table – pin 15 or pin 16 are most convenient.

In all modes, the lower input level corresponds to 0% of maximum output voltage and the upper level to 100% of maximum output voltage (i.e. 30 kV or 60 kV depending on generator model).

In the voltage input modes (0 - 5 V, 0 - 10 V), the input impedance is 13 k $\Omega$  to GND.

In the current input modes (0 - 20 mA, 4 - 20 mA), the input impedance is 250  $\Omega$  to GND.

The input is protected against transient over-voltage but may be damaged by applying a low-impedance voltage source exceeding 28 V.



In the current input modes (0 - 20 mA and 4 - 20 mA), a remote interface overcurrent error will occur if the signal current exceeds 24 mA. This is indicated by a 'REMOTE OVER!' message on the display. If this occurs, check the signal applied to the input pin.



---

## 10. Remote Interface

---

The wiring example below shows the remote voltage setpoint supplied by an external control voltage source (e.g. a PLC analogue output). In this case 'Vprog Mode' (parameter 1.4) would need to be set to '0 - 10 V'.

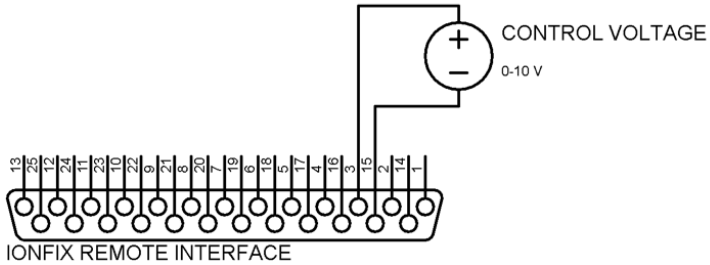

AS VIEWED LOOKING AT REAR OF GENERATOR

If the front panel voltage setpoint adjustment buttons are pressed when the external voltage setpoint function is enabled, a warning message will be shown.



---

## 10. Remote Interface

---

### 10.5. Remote current setpoint input (pin 2)

The remote current setpoint input (pin 2) allows the output current limit of the generator to be programmed by an analogue voltage or current signal.

To use the remote current setpoint function, it must first be enabled in the generator configuration menu by setting parameter 1.3 to 'ON'.

Item	Name	Description	Default Value	Parameter Range
1.3	Remote ISp	Enable/disable remote current setpoint.	OFF	ON/OFF

The external voltage setpoint input (pin 2) can be configured to accept 4 different signal types via the remote mode menu.

Item	Name	Description	Default Value	Parameter Range
1.5	Iprog Mode	Change current setpoint input mode.	0 - 10 V	0 - 10 V 0 - 20 mA 0 - 5 V 4 - 20 mA

The input signal must be ground-referenced. The signal ground may be connected to any of the GND pins in the table – pin 15 or pin 16 are most convenient.

In all modes, the lower input level corresponds to 0% of maximum output current and the upper level to 100% of maximum output current (i.e. 2.5 or 5 mA depending on generator model).

In the voltage input modes (0 - 5 V, 0 - 10 V), the input impedance is 13 k $\Omega$  to GND.

In the current input modes (0 - 20 mA, 4 - 20 mA), the input impedance is 250  $\Omega$  to GND.

The input is protected against transient over-voltage but may be damaged by applying a low-impedance voltage source exceeding 28 V.



In the current input modes (0 - 20 mA and 4 - 20 mA), a remote interface overcurrent error will occur if the signal current exceeds 24 mA. This is indicated by a 'REMOTE OVER!' message on the display. If this occurs, check the signal applied to the input pin.



---

## 10. Remote Interface

---

The wiring example below shows the remote current limit supplied by an external control voltage source (e.g. a PLC analogue output). In this case 'Iprog Mode' (parameter 1.5) would need to be set to '0-10 V'.

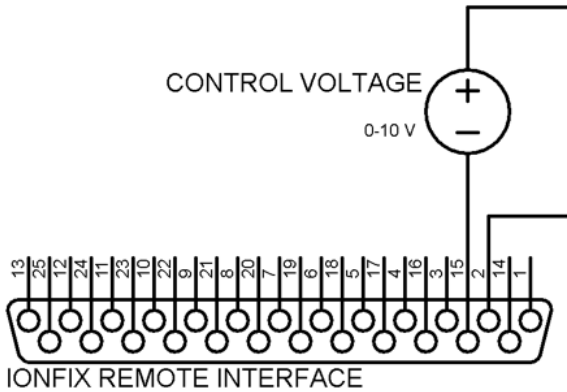

AS VIEWED LOOKING AT REAR OF GENERATOR

If the front panel current limit adjustment buttons are pressed when the external current limit function is enabled, a warning message will be shown.



---

## 10. Remote Interface

---

### 10.6. Remote voltage monitor output (pin 4)

The remote voltage monitor output (pin 4) allows the present output voltage of the generator to be monitored remotely. This signal may be fed into a PLC system, or used to drive a panel meter.

The voltage monitor output is always active, and always reports the actual measured output voltage of the generator. Note that if the current limit is active, the actual output voltage will be less than the demanded setpoint voltage (e.g. if the generator is heavily loaded).

The remote voltage monitor output may be configured to provide four different ground-referenced signal types via the remote mode menu.

Item	Name	Description	Default Value	Parameter Range
1.6	Vsns Mode	Change voltage monitor output mode.	0 - 10 V	0 - 10 V 0 - 20 mA 0 - 5 V 4 - 20 mA

Any of the GND pins may be used as a reference for this signal.

The voltage monitor output is protected against short circuit to GND, and applied voltages up to +28 V. The output impedance of the signal driver circuit is approximately 150  $\Omega$ .

The wiring example below shows a panel meter connected the remote voltage monitor output, with the output configured in 0 - 10 V mode on a 30 kV generator.

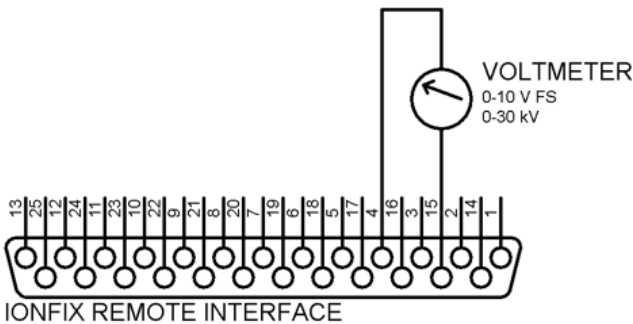

AS VIEWED LOOKING AT REAR OF GENERATOR

---

## 10. Remote Interface

---

### 10.7. Remote current monitor output (pin 5)

The remote current monitor output (pin 5) allows the present output current of the generator to be monitored remotely. This signal may be fed into a PLC system, or used to drive a panel meter.

The current monitor output is always active, and always reports the actual measured output current of the generator. Note that if the current limit is not active, the actual output current will be lower than the demanded current limit (e.g. if the generator is lightly loaded).

The remote current monitor output may be configured to provide four different ground-referenced signal types via the remote mode menu.

Item	Name	Description	Default Value	Parameter Range
1.7	Isns Mode	Change current monitor output mode.	0 - 10 V	0 - 10 V 0 - 20 mA 0 - 5 V 4 - 20 mA

Any of the GND pins may be used as a reference for this signal.

The current monitor output is protected against short circuit to GND, and to voltages up to +28 V. The output impedance of the signal driver circuit is approximately 150  $\Omega$ .

The wiring example below shows a panel meter connected the remote current monitor output with the output configured in 0-10 V mode on a 30 kV generator.

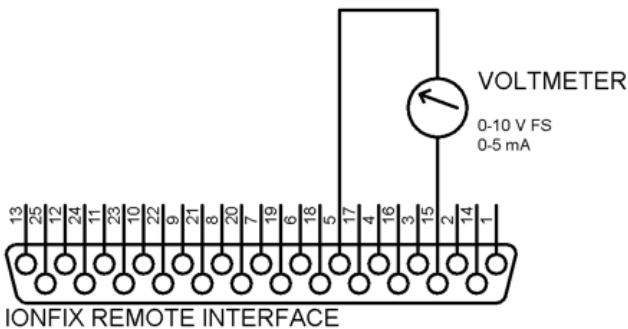

AS VIEWED LOOKING AT REAR OF GENERATOR

---

## 10. Remote Interface

---

### 10.8. Arc/Limit output (pins 9, 22)

The arc/limit output signals that a condition exists which is preventing the generator HV output level from reaching the demanded voltage setpoint. The operation of this output may be configured via the remote mode menu.

Item	Name	Description	Default Value	Parameter Range
1.8	Arc/Lim Mode	Change overload signalling mode.	Lim/Arc	Lim/Arc Arc Limit

The three signalling modes operate as follows:

- **Lim/Arc mode:** output activated when current limit reached **OR** arc/overload occurs.
- **Arc mode:** output activated **ONLY** when arc/overload occurs.
- **Limit mode:** output activated **ONLY** when current limit reached.

An overload condition is determined to exist when the load impedance is less than 500 k $\Omega$  (30 kV) or 1 M $\Omega$  (60 kV). In the case of an overload or arc fault, the overload output will remain active whilst the generator HV output is disabled for a period of 4 seconds.

This is an optically-isolated switching output, with the open collector on pin 9 and open emitter on pin 22. This output can switch up to 30 V with a load current of 50 mA in order to drive a relay, indicator, PLC input, etc.

To provide a PLC-compatible signal, connect +24 V (supplied externally) to pin 9, and connect the PLC input to pin 22.

The wiring example below shows the Arc/Lim output connected to a PLC system using an external power source to provide the 24 V signal level.

## 10. Remote Interface

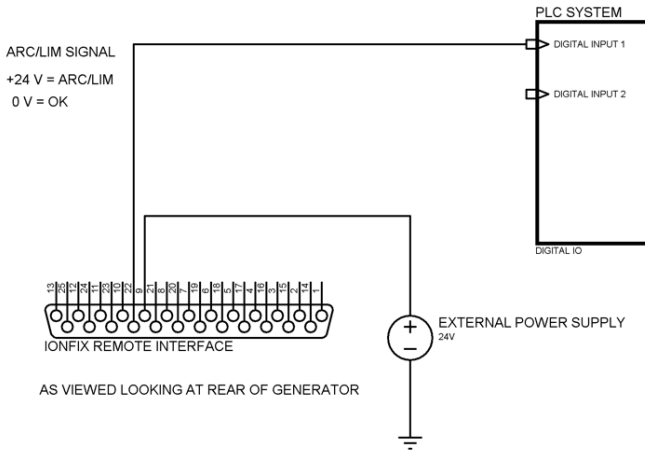

## 10. Remote Interface

### 10.9. Operating output (pins 10, 23)

The operating output is activated when all of the following conditions are satisfied:

- HV output enabled via **either** the front panel run/stop button or the remote on/off input.
- Voltage setpoint **not** set to zero.
- Current limit **not** set to zero.
- **No** fault conditions present (input under-voltage, arc fault, over temperature, etc).

The operating output therefore signals that the generator is producing a high voltage output and is not experiencing any fault conditions.

This is detailed in the truth table below:

Remote on/off input 0: low (ENABLE = 0) 1: high (ENABLE = 1)	Front panel run/stop button 0: not pressed/ toggled 1: pressed/ toggled	Voltage setpoint and current limit 0: either = 0 1: neither = 0	Fault (any) 0: not present 1: present	Operating signal
0	0	0	0	INACTIVE
0	0	0	1	INACTIVE
0	0	1	0	INACTIVE
0	0	1	1	INACTIVE
0	1	0	0	INACTIVE
0	1	0	1	INACTIVE
0	1	1	0	ACTIVE
0	1	1	1	INACTIVE
1	0	0	0	INACTIVE
1	0	0	1	INACTIVE
1	0	1	0	ACTIVE
1	0	1	1	INACTIVE
1	1	0	0	INACTIVE
1	1	0	1	INACTIVE
1	1	1	0	ACTIVE
1	1	1	1	INACTIVE

---

## 10. Remote Interface

---

This is an optically-isolated switching output, with the open collector on pin 10 and open emitter on pin 23. This output can switch up to 30 V with a load current of 50 mA in order to drive a relay, indicator, PLC input etc.

To provide a PLC-compatible signal, connect +24 V (supplied externally) to pin 10, and the PLC input to pin 23.

The wiring example below shows the operating output connected to a PLC system using an external power source to provide the 24 V signal level.

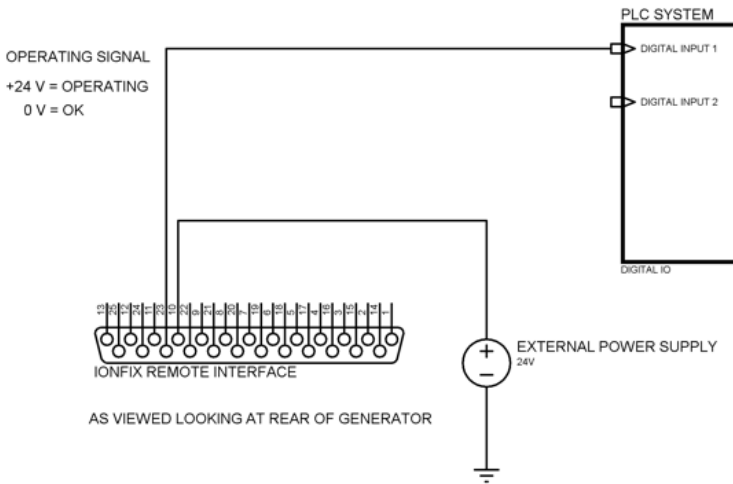

### 10.10. +12 V reference output (pin 7)

A 12 V reference output is supplied on pin 7 of the remote interface. This may be used to provide a signal for the remote on/off input. The maximum current that may be drawn from this output is 20 mA.

---

## 11. Technical Specifications

---

### Power Supply Requirements

#### Both Variants

<b>Input voltage:</b>	90 – 250 V AC, 50/60 Hz.
<b>Input current:</b>	3 A max.
<b>Maximum input power:</b>	240 W.
<b>Input connector:</b>	IEC 60320 C14 inlet. Mating plug IEC 60320 C13.
<b>Fuse type and rating:</b>	5 x 20 mm, 3 A - type 'F' (fast-blow characteristic).

### Electrical Output Characteristics: 30 kV Variant

<b>Output voltage:</b>	0 – 30 kV, adjustable in 0.1 kV increments.
<b>Output current limit:</b>	5 mA max. Adjustable from zero to max. in 0.01 mA increments.
<b>Maximum output power:</b>	150 W, available at 30 kV.
<b>Output voltage rise time:</b>	60 ms.

### Electrical Output Characteristics: 60 kV Variant

<b>Output voltage:</b>	0 – 60 kV, adjustable in 0.1 kV increments.
<b>Output current limit:</b>	2.5 mA max. Adjustable from zero to max. in 0.01 mA increments.
<b>Maximum output power:</b>	150 W, available at 60 kV.
<b>Output voltage rise time:</b>	100 ms.

### Electrical Output Characteristics: Both Variants

<b>Output voltage fall time:</b>	10 ms full-load, 600 ms no-load.
<b>Output connector type:</b>	4 x Fraser 30/60 kV tubular spring-contact HV connector.
<b>Output voltage ripple:</b>	Max. 5% of full output voltage (peak-to-peak), at full load condition.

## 11. Technical Specifications

Protection	
<b>Short-circuit protection:</b>	Continuous output current electronically limited.
<b>Output arcing protection:</b>	HV output disabled for 4 seconds in event of arcing.
<b>Thermal protection:</b>	HV output disabled if internal temperature exceeds safe limit.
<b>Minimum load impedance:</b>	30 kV variant: 0.5 M $\Omega$ – below this, output will be disabled. 60 kV variant: 1 M $\Omega$ – below this, output will be disabled.

Remote Interface	
<b>Connector type:</b>	25-pin subminiature D-type, female. Mating plug Amphenol L717DB25P or equivalent.
<b>Remote control functions:</b>	HV on/off (digital, 10 - 30 V 'on', 10 - 25 mA input current). Voltage set point adjust (analogue, configurable: 0 - 5 V, 0 - 10 V, 0 - 20 mA or 4 - 20 mA = 0 - 100 %). Current set point adjust (analogue, configurable: 0 - 5 V, 0 - 10 V, 0 - 20 mA or 4 - 20 mA = 0 - 100 %).
<b>Remote monitoring functions:</b>	Overload or arc fault (configurable) output. Operating status output. Open collector/emitter outputs provided, 50 V/50 mA maximum load. Remote voltage monitor (analogue, configurable: 0 - 5 V, 0 - 10 V, 0 - 20 mA or 4 - 20 mA = 0 - 100 %). Remote current monitor (analogue, configurable: 0 - 5 V, 0 - 10 V, 0 - 20 mA or 4 - 20 mA = 0 - 100 %).
<b>Auxiliary power supply:</b>	12 V, 20 mA. May be used to drive remote on/off input.

---

## 11. Technical Specifications

---

### Environmental Conditions

<b>Ambient temperature:</b>	0 – 50 °C
<b>Relative humidity:</b>	Maximum 70 % rH, non-condensing.
<b>Ingress protection:</b>	IP20 (must not be exposed to falling, splashing or spraying water).
<b>Vibration:</b>	Installation location must be vibration-free.
<b>Mechanical fixing:</b>	Fixing brackets supplied.

### Mechanical

<b>Dimensions (W x H x D):</b>	264 mm x 105.25 mm x 337 mm
<b>Mass:</b>	8 kg

### Options

<b>No-cost options:</b>	Display orientation ('desktop' or 'wall-mount').
-------------------------	--

---

## 11. Technical Specifications

---

### 11.1. Dimensions

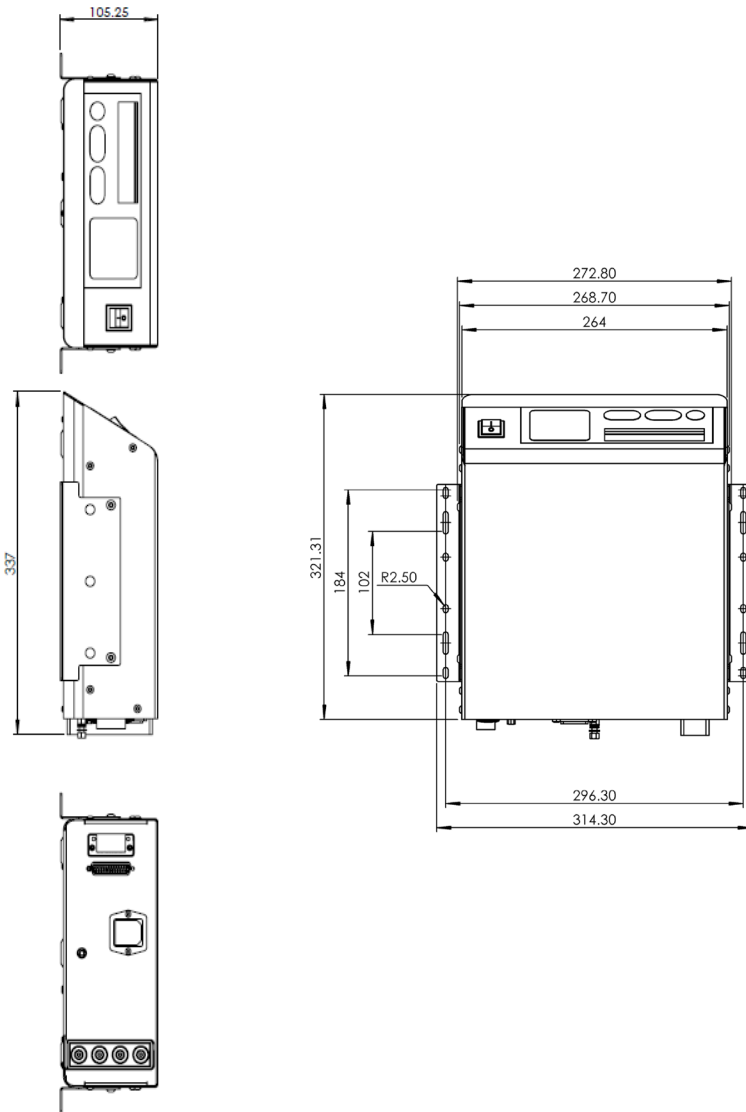

## 12. Troubleshooting

In case of problems with the generator, consult the following table to aid diagnosis and remedy.

Problem	Cause	Remedy
No output voltage Display off	Power supply not connected or energised.	Check power supply connections.
	Inlet fuse blown.	Replace fuse.
	Hardware fault.	Contact distributor.
No output voltage Display on	Voltage setpoint not changed from default 0.0 kV or remote setpoint not provided.	Change setpoint using Voltage +/- buttons or provide signal on remote interface.
	Remote on/off enabled, but no remote on/off signal provided.	Provide remote on/off signal.
	Current limit set too low.	Increase current limit using Current +/- buttons.
All LEDs flashing 'OVERLOAD' shown on display	Arcing or short-circuit on HV output due to electrode or cable fault.	Check and rectify electrode or cable faults.
	Generator overloaded.	Move charging electrode(s) further from counter-electrode.
All LEDs flashing 'OVER TEMP' shown on display	Generator internal temperature too high.	Move generator to cooler location. Reduce loading on generator
All LEDs flashing 'UNDER VOLTAGE' shown on display	Supply voltage too low.	Check supply voltage.
All LEDs flashing 'OVER VOLTAGE' shown on display	Supply voltage too high.	Check supply voltage.
All LEDs flashing 'INPUT OVERI' shown on display	Current mode input signal level too high.	Check input signals.
All LEDs flashing Any other message shown on display	Internal fault with generator.	Contact distributor.

---

## 13. Maintenance and Repair

---

### 13.1. Maintenance

Keep the generator dry and free of dust, dirt, corrosive substances and solvents. Avoid touching the plastic barrel of the high voltage connectors when connecting or disconnecting charging electrodes.

Regularly check the earthing of the generator to ensure continued safety and correct operation.

Regularly inspect the high-voltage connectors and cables for mechanical or electrical damage.

There are no parts requiring periodic maintenance within the generator.

### 13.2. Repairs

In the event of a fault with the generator which cannot be rectified by following the steps detailed in 'troubleshooting', contact your Fraser distributor in the first instance.

The generator has been designed to allow the major internal components to be easily replaced. This must only be carried out by suitably qualified and trained persons, and using genuine replacement parts supplied by Fraser Anti-Static Techniques.

In some cases it may be necessary for the generator to be returned to Fraser Anti-Static Techniques for investigation and repair. Please contact Fraser with the symptoms of the fault encountered, including any error messages displayed by the generator to determine if this is necessary.

---

## 14. Disposal

---

Dispose of the generator in accordance with local environmental regulations pertaining to electrical waste.

---

## 15. Spare Parts

---

The following spare parts are available for the IONFIX PRO Generator.

Part No.	Description
73021	Fraser HV connector kit, 30/60 kV
81290	DB-25 connector, screw terminals.
81361	Fuse (5 x 20 mm, 3 A type F)
730218	Blanking plug for HV socket.

---

**This page intentionally blank**

---

---

**This page intentionally blank**

---

---

**This page intentionally blank**

---

For more information about static and to view the full range  
of our products, please visit [www.fraser-antistatic.com](http://www.fraser-antistatic.com)



Scotts Business Park, Bampton, Devon, EX16 9DN, UK  
T + 44 (0) 1398 331114 F + 44 (0) 1398 331411  
E [sales@fraser-antistatic.co.uk](mailto:sales@fraser-antistatic.co.uk) W [www.fraser-antistatic.com](http://www.fraser-antistatic.com)