



NEOS 20
WITH INTEGRATED REMOTE MONITOR



Fraser static control equipment has been designed to give you many years of productive service. However, the science of static control has unique rules which must be followed to allow the equipment to give a good return on your investment.



Please read the following operating and maintenance instructions carefully.

Contents	Page
1. Introduction.....	4
2. Safety	5
3. Use	6
4. Checking on Delivered Equipment.....	6
5. General Specification and Dimensions.....	7
6. Positioning	8
7. Operation and Control.....	12
8. Mechanical.....	22
9. Maintenance	22
10. Certification and Declaration of Conformity	23
11. Troubleshooting.....	23
12. Spare Parts and Accessories	24

1. Introduction

This manual applies to all NEOS 20 Static Eliminator bars supplied from December 2015.

It is essential that you read and understand the complete manual before installing and using this equipment. This is important for safety and for warranty cover.

1.1 Explanation of Symbols

Warning!

This symbol appearing in the operating instructions refers to operations which, if carried out improperly, can result in serious personal injuries.



Caution!

This symbol appearing in the operating instructions refers to operations which, if carried out improperly, can result in damage to property.



2. Safety

Warnings:

- The NEOS 20 Anti-Static Bar is only designed for neutralising surfaces with an electrostatic charge.
- Electrical installation must only be carried out by suitably qualified personnel.
- Adequate installation earth/ground is required to ensure safe and proper operation.
- The 0 V return of the 24 V DC electrical supply must be earthed.
- Disconnect the power supply before cleaning or handling the bar.
- The emitters are sharp and can cause physical injury.
- There are no user serviceable parts inside the bar.
- Ensure the bar and connecting cable are free from damage prior to installation and check periodically once in use.
- Bar must be switched off before adjusting the rotary switch.
- A small amount of ozone will be produced as part of the ionisation process. When installed correctly the level of concentration of ozone is less than 0.1 ppm and is within internationally accepted limits.



Any changes to the equipment without written consent of the manufacturer will nullify the warranty and certifications.

As with all pulsed DC static eliminators, it is possible for the user to receive a small static shock as a result of their body being charged by the bar, and then discharging to a nearby earthed object. This is not dangerous, but may be uncomfortable and cause surprise. It is for this reason that the rotary switch should only be adjusted when the bar is not powered.



3. Use

- The NEOS 20 is a high performance Static Eliminator Bar designed to neutralise electrostatically charged surfaces.
- Powered by 24 V DC, the NEOS 20 has an integrated HV supply and features remote monitoring to check bar function remotely.
- Connection to 24 V DC is via a standard M12 5-pin Connector.
- The NEOS 20 is not suitable for outdoor use.

4. Checking on Delivered Equipment

The equipment leaves our factory in suitable protective packaging. Please check that it is undamaged when it arrives. If there is visible damage, contact the Factory or one of our Distributors immediately before carrying out any installation.

Check that the parts which have been delivered are the same as you have ordered.

Loose Parts: Bars up to 1,000 mm in length are supplied with two 'T' fixings.
Extra 'T' fixings are supplied for each additional 500 mm or part thereof. For example:

750 mm:	2 'T' fixings
1,350 mm:	3 'T' fixings
1,800 mm:	4 'T' fixings

It is important to use all of the supplied 'T' fixings.

Emitter Key and two spare emitters.

M12 5-pin Connector and lead or Power Supply Unit

- as per order.

5. General Specification and Dimensions

Power Supply:	Voltage: 24 V DC (21 - 28 V DC). Current: 2.0 A DC Max. Connection: M12 5-pin. A-coded.
High Voltage:	20 kV integrated into bar.
Supply cable:	Low voltage, industry standard M12 5-pin female connector.
Emitters:	Long life, high grade Tungsten.
Status indication:	LED: Green/Green Flashing = OK. Red Flashing = Standby. Red = Fault. Red/Green Flashing = Attention required.
Signalling:	OK/Attention: Open-collector outputs. Remote DISABLE input.
Environmental:	IP67. Internal use. 0 - 55 °C Max. Dry: max 70 % RH, non condensing.
Length:	Available from 450 mm to 4,950 mm in 150 mm steps.
Weight:	2.6 kg/m.
Mounting:	'T' fixing with two M6x40 mm studs and flange nuts. Other lengths available.
Approvals:	CE, UL and CB.

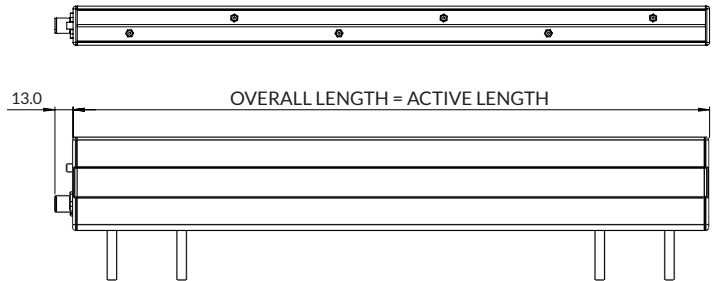
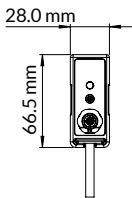

Overall length = order length + 6 mm (including end caps)

6. Positioning

The best location is at, or immediately before, the area where static is causing the problem. Remember that static can be regenerated if the material passes over rollers or through a process after neutralising. A Static Meter such as the Fraser 715 is useful to determine the best position.



Important: Except on a winding reel of material (see the examples on the following pages), the material to be neutralised must be in free air, not touching another surface as it passes the bar. It is not possible to neutralise static electricity where the material is touching another surface or roller.

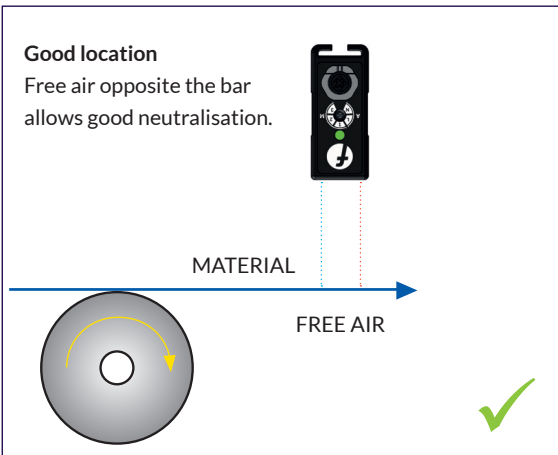
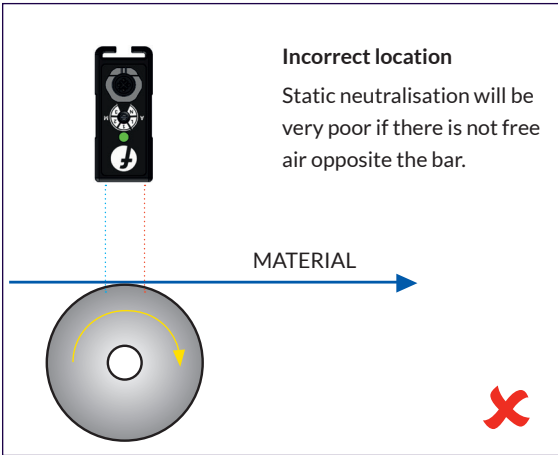

6. Positioning

Generally, with a rewind or unwind, it is desirable to use a long-range bar to cope with the changing geometry so that you can neutralise the reel from the core to the finished diameter at the end of the wind.

There is an optimum location to neutralise the reel, which is shown by the following diagrams.

The principle is to neutralise the film AFTER it leaves the final roller and as it joins the reel.

Lay-on or Contact Roller Example

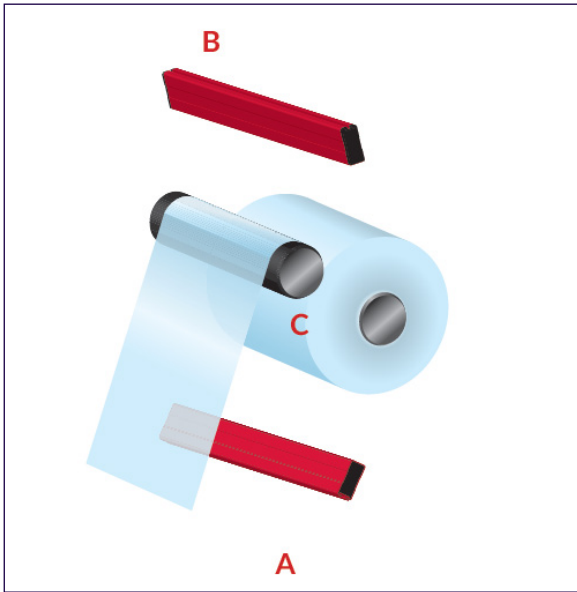

If there is a lay-on or contact roller (C), the best position for the NEOS 20 is on the side where the film leaves the lay-on roller - in this case the underside (A) - because it can neutralise the charge as soon as it is created. If this is not practical, then position the bar on the top side. (B)

6. Positioning

Centre Winder Example

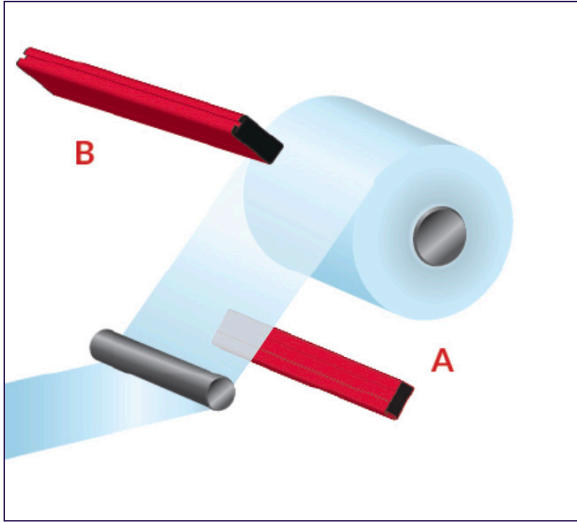

On a centre winder the NEOS 20 may be positioned above or below the reel. It is a good idea for the ionisation to be directed mainly at the reel, but also catching the single sheet, as shown at (A). Position (B) is also acceptable.

It is often not possible to place a bar in the optimum position (A). The reason for this may be that the ideal bar location would get in the way of the loading/unloading process for the reels or would be in a position where operators might stand on it.

In a dirty or dusty environment, it is better to place the bar facing down, since the face of the bar will not be covered by the dust. This is not a problem. It is possible to position the bar at other positions, such as (B) and still achieve a very good result.

We always say that a film web must be in 'free air' and not touching a roller to achieve good neutralisation. This is because we know that the charge on the material will temporarily combine with the roller and not be available for removal by the eliminator. This remains true. However, once you have a number of layers on a reel or winder, all with the same polarity of charge on them, the charge can no longer combine and can therefore be neutralised layer by layer.

6. Positioning

Note: Long bars need careful handling during installation to avoid damage. Bars longer than 2,000 mm must be handled by two people.



- Use all of the 'T' fixings provided for mounting the bar. The 'T' fixings slide into the slot in the bottom of the bar. When mounting the bar, the 'T' fixings must be evenly distributed along the length of the bar. Do not allow more than 800 mm of unsupported bar between 'T' fixings.
- The bar must be dry and oil-free.
- Only mount the bar with the slot touching the machine or the mounting bracket.
- When mounting to the machine or on a bracket, make sure no metal extends beyond the slot in the bar. See the diagram below.

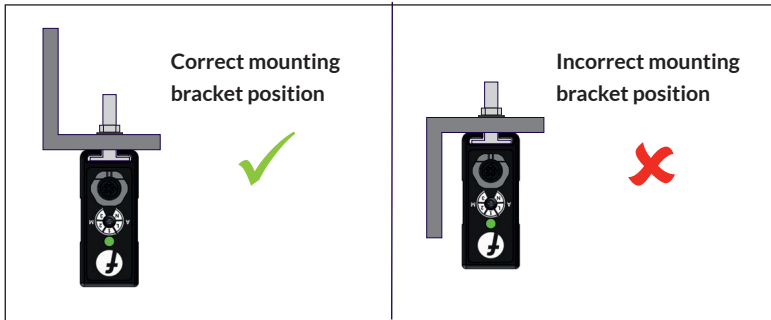

- It is important that the emitter pins are not touching, or close to metal objects, to avoid spark erosion that will damage both the bar and the metal object.
- The distance from the material should be: 150 - 800 mm. Neutralisation performance is always better when the static eliminator bar is positioned closer to the material - subject to the minimum distance requirement.

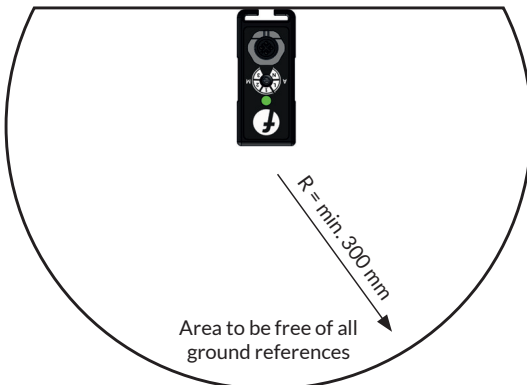

7. Operation and Control

7.1 Intelligence and Settings

The NEOS 20 bar gives the operator the ability to generate market leading static elimination for better control of processes, quality and safety.

The NEOS 20 bar is a pulsed-DC static eliminator with five settings: three manual and two automatic (intelligent). The settings are selected using the rotary switch on the endcap of the bar.

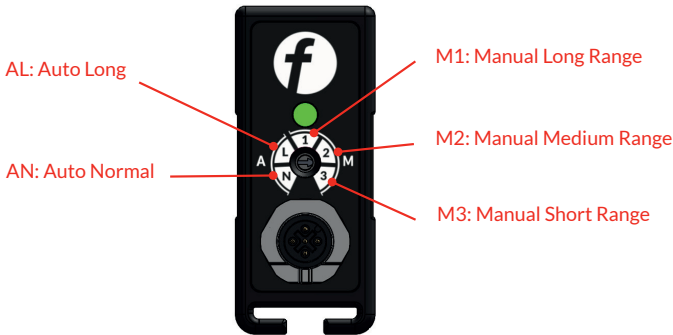

Manual Settings

Manual settings allow the bar to be operated as a conventional pulsed DC static eliminator - slowing the frequency of the ion emission to cope with longer distance neutralisation.

The three manual settings are:

- M1 for Long Range - using a low frequency.
- M2 for Medium Range - using a medium frequency.
- M3 for Short Range - using a higher frequency.

7. Operation and Control

Automatic Settings - NEOS Intelligence

The automatic settings, AN and AL, give the operator the ability to double the neutralisation power of the manual settings by using NEOS Intelligence.

NEOS Intelligence monitors the charge in the object and adjusts the ion emission to achieve faster neutralisation. It adjusts the polarity, duty cycle and frequency of the ion emission to suit the application.

There are practical limits to the sensing capability of NEOS - if the electric field is weak or at a long distance it will be more difficult to monitor.

For this reason there are two automatic settings available: AN and AL

- AN (Auto Normal) is for shorter distances

- AL (Auto Long) is for longer distances

7. Operation and Control

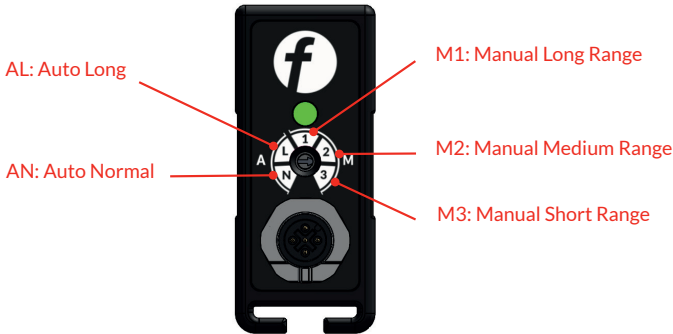

Selecting the Best Setting

The factory setting for the NEOS 20 is AL: Auto Long.

This gives intelligent operation at medium/long distances.

This setting can be changed to meet the actual requirements of the installation.

Typical reasons for this could be:

1. Distance

The Manual setting M1 is for longest distances to the object to be neutralised.

The sensing intelligence from the automatic settings loses sensitivity with distance, especially if the static charge level is not high. See the distance chart on the next page for guidance.

2. Installation

If there are metal parts in the target area or close to the NEOS bar, this could interfere with the sensing - giving it misleading information.

See bar positioning in section 6.

3. Intermittent Static Charge

For example, if the product is not continuously present there is no charge to sense. In this case it can be better to use a Manual Setting to flood the area with ions.

4. Speed of Process

Faster material speeds benefit from closer distances and faster frequencies.

A small amount of experimentation may be needed to produce the best performance for the application. The settings can be changed by turning the slot in the endcap. Use a 2 mm plastic screwdriver.

Turn off the bar when changing the setting.

See the distance chart on the next page for the typical range of each setting.



7. Operation and Control

7.2 Distance for Each Setting

Pulsed DC static neutralisation is designed for longer range performance. The actual performance is also influenced by the size of the static charge - the higher the static charge, the longer the range of the static eliminator.

This rule applies to NEOS intelligence too - the higher the static charge, the better the sensing operation.

The following chart gives operational distances for the NEOS 20 bar and settings at a moderate charge level of 20 kV. There is considerable overlap between settings.

Settings	NEOS 20
AN (Auto Normal)	250 - 400 mm
AL (Auto Long)	200 - 750 mm
M1 (Manual Long)	200 - 800 mm
M2 (Manual Medium)	150 - 600 mm
M3 (Manual Short)	150 - 500 mm

Important:

The distances stated above are the operational ranges for each setting. It should be noted that neutralisation performance is always better when the static eliminator bar is positioned closer to the material - subject to the minimum distance requirement.

7. Operation and Control

7.3 Electrical

Using an Existing 24 V DC Supply:

The 24 V return must be fitted with a 2.0 Amp fuse e.g. Type: 2.0 A, T, 250 V.

The 0 V output must be connected to earth.

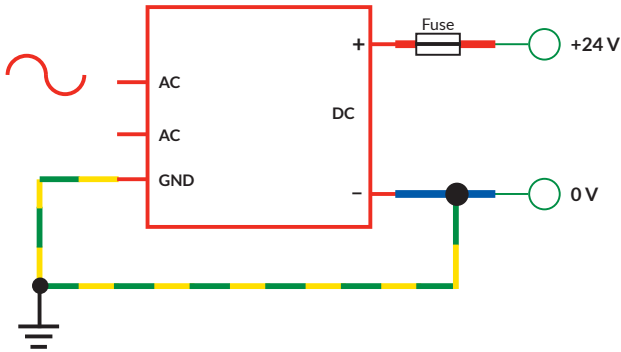

M12 Connector Pin Functions

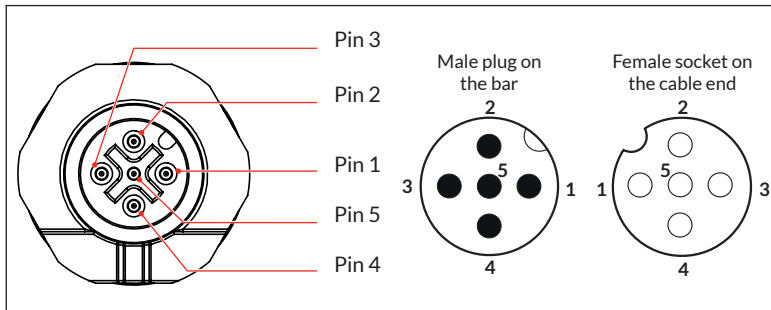

Pin	Colour	Function
1	Brown	+24 V DC
2	White	OK
3	Blue	0 V and Earth
4	Black	Attention
5	Grey or Green/Yellow	Disable

7. Operation and Control

7.4 Signalling

The NEOS bars feature two open-collector outputs to enable remote monitoring of bar status, and a logic-level DISABLE input to allow the HV supplies to be externally disabled when not required (“Standby” mode). For example, the bar can be linked into a machine’s safety interlock system to ensure operator safety during changeover periods.

See wiring diagram and examples below.

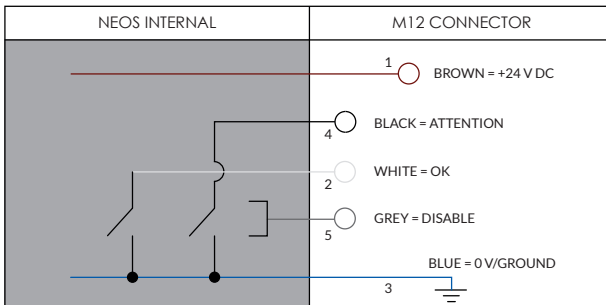
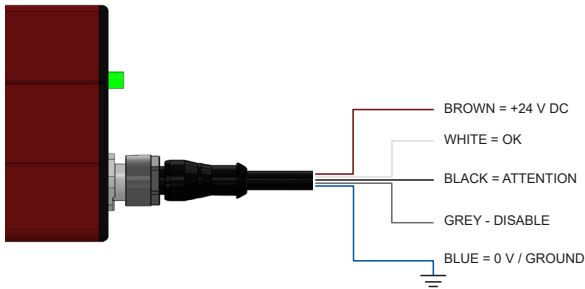

Open-collector outputs (OK, ATTENTION)

Both open-collector outputs are capable of sinking a current of up to 200 mA, allowing direct driving of external lamps or relays, or an external LED with a suitable current limiting resistor. An external pull-up resistor may be used to provide a logic-level or 24 V signal voltage to a PLC or other destination. See wiring diagram and examples in the next section.

Both output signals are active low, meaning that a signal is asserted by a connection to 0 V via a low-powered solid-state switch. The two signals are valid 5 seconds after power is applied, according to the following conditions:

7. Operation and Control

Condition	Ionisation	OK (White, Pin 2)	Attention (Black, Pin 4)
Bar powered: all OK	ACTIVE (HV ON)	ACTIVE (connected to 0 V)	ACTIVE (connected to 0 V)
Bar powered, requires attention (e.g. cleaning)	ACTIVE (HV ON)	ACTIVE (connected to 0 V)	INACTIVE (open-circuit)
Bar not powered: overload or hardware fault	INACTIVE (HV OFF)	INACTIVE (open-circuit)	INACTIVE (open-circuit)
Standby mode	INACTIVE (HV OFF)	INACTIVE (open-circuit)	ACTIVE (connected to 0 V)

A working bar in good operating condition will thus internally connect both open-collector outputs to 0 V, after a delay of up to 5 seconds after power is applied.

If the open-collector outputs are not required, the black wire and the white wire should be connected to 0 V (blue wire).

Voltage applied to open-collector outputs must not exceed 28 V DC, and must be of the correct polarity.



The current through the open-collector switch must not exceed 200 mA. Failure to limit the current into the open-collector outputs may cause permanent damage to the product. Do not connect the open-collector outputs directly to 24 V DC.

7.5 Example Applications of Open-collector Outputs

External Lamp/Indicator

External lamps or indicators can be connected to the OK or ATTENTION outputs to remotely display bar status. This is useful for bars mounted in inaccessible areas. Lamp rating 24 V DC, maximum 5 W. An LED can also be used with a suitable resistor. Maximum lamp current 200 mA.

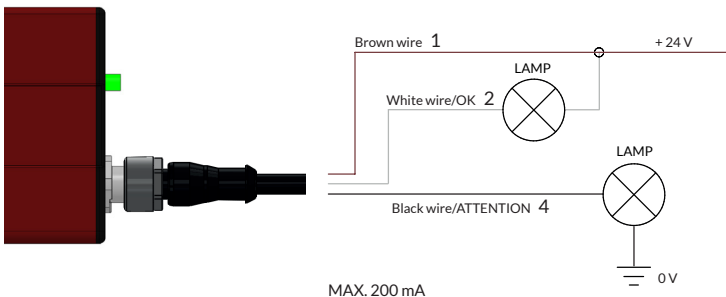

7. Operation and Control

External Relay

An external relay can be connected for additional control/feedback applications.

Coil rating: 24 V, 5 W max.

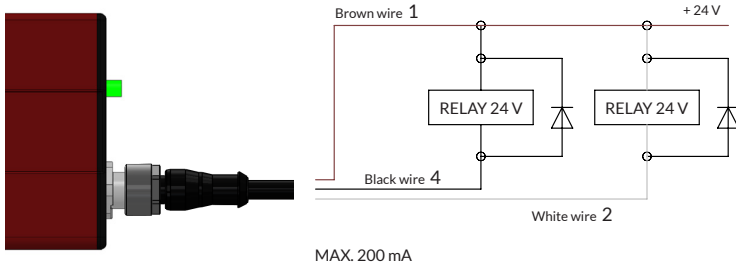

External PLC

A voltage signal suitable for interfacing with a PLC or other control system can be obtained using an external pull-up resistor.

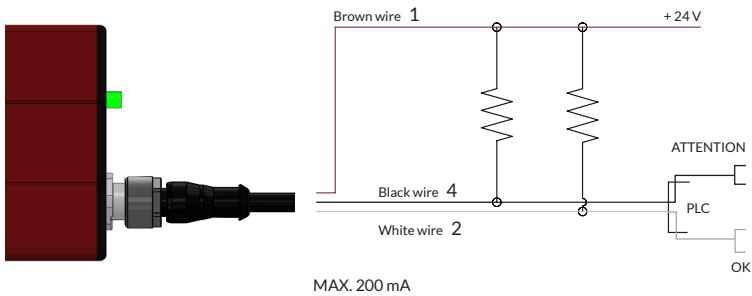

7. Operation and Control

The voltage connected to the external pull-up resistor must correspond to the required high-level PLC input voltage, up to a maximum of 28 V. If the high-input voltage of the PLC is 24 V, then the pull-up must be connected to 24 V (as shown on page 15). If the input is 'logic-level' or 'TTL-level', then the pull-up should be connected to a lower voltage such as 5 V.



Remote DISABLE Input

The NEOS 20 bar features a remote DISABLE input signal (Grey or Green/Yellow wire). This can be useful for installations in which the bar is not used continuously and it is desirable that the bar should be inactive when not required, or in installations in which the operation of the bar is to be interlocked with other machinery.

The HV supplies can be externally disabled (Standby mode) by applying any DC voltage between 3 V and 28 V to the DISABLE input, for example by using an external switch or relay contact between the DISABLE input and 24 V, or a logic-level voltage signal. Subsequently reducing the voltage at the DISABLE input to less than 0.5 V restores normal operation of the bar.

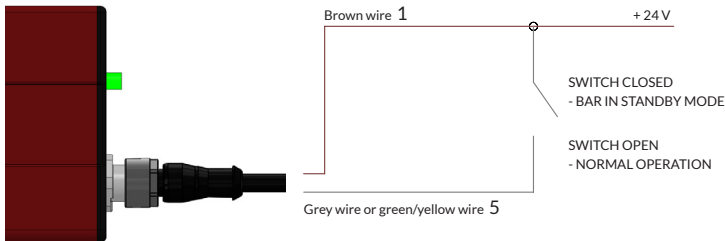

In Standby mode the bar internal HV supplies are disabled, the status LED flashes red, and the OK output is inactive (open circuit) to indicate that ionisation is disabled. The DISABLE signal has a weak internal pull-down resistor, thus if the DISABLE signal is left disconnected the bar will operate normally. However, for added noise immunity it is recommended that the DISABLE input is externally connected to 0 V (blue wire) if not required.

Voltage applied to the DISABLE input must not exceed 28 V DC, and must be of the correct positive polarity. The bar can be permanently damaged by connecting the DISABLE input to any voltage outside the range of 0 V to 28 V DC.



Where the optional NEOS-PSU has been ordered ensure the Power Unit is connected to a 3-wire AC mains supply: Live + Neutral + Ground, and that the extra Earth wire from the power supply is bonded to Ground. With this optional supply an interface cable is required to access the remote monitor feature.



7. Operation and Control

7.6 Status LED



Bar State	LED State	LED State (Intelligence Active)
Auto Normal	Pulse Green	Rapid Flash Green
Auto Long	Double Pulse Green	Rapid Flash Green
Manual 1, 2, 3	Slow, Medium or Fast flashing depending on the mode selected	N/A

IONISATION ACTIVE IN THIS STATE



Bar State	LED State	Cause	Action
Attention	Red/Green Alternate Flash	- Dirty bar or abnormal conditions	<ul style="list-style-type: none"> - Clean bar - Check installation - Check process

IONISATION ACTIVE IN THIS STATE



Bar State	LED State	Cause	Action
Fault	Solid Red	<ul style="list-style-type: none"> - Power supply not within 21 - 28 V - Internal fault - Overload 	<ul style="list-style-type: none"> - Check power supply - Check input voltage - Check HV at pins - Check bar is correctly wired - Check bar is correctly positioned
Standby	Flashing Red	- DISABLE signal active (3 - 28 V)	

IONISATION NOT ACTIVE IN THIS STATE

8. Mechanical

Versatile 'T' fixings slide into the slot in the bottom of the bar. Two 'T' fixings are supplied for bars up to 1,000 mm, plus 1 extra 'T' fixing for each additional 500 mm.



9. Maintenance

Turn off power supply to the bar before doing any installation or maintenance work (including adjusting the rotary switch).



Cleaning is the only maintenance required. Dirt around the emitters will reduce efficiency and result in unsatisfactory performance.

Our Fraser cleaning kit (Part No. 81220) is ideal for use, alternatively a toothbrush or nail brush can be used. Do not use a wire brush as this could damage the bar.

The bar can be washed with soapy water or isopropyl alcohol (IPA), but it must be dry around the emitters before turning the power on.

Please note, when handling and cleaning, that the emitter pins are sharp and care is needed!



The emitter pins are shockless - there is a large resistor below each emitter reducing the current to a shockless level. However please note that DC current can transfer charge to a body if it is touching or close to an emitter for a longer period. This could give a shock when discharging.



The emitters on the NEOS 20 bar should be replaced every two years. Please use the emitter key supplied with the bar to remove/replace.

10. Certification and Declaration of Conformity

We declare that this equipment conforms to the Low Voltage Directive and EMC Directive. It is entitled to display the CE and UL marks.

For further instructions and information, please contact the manufacturer.

11. Troubleshooting

On power-up, the status LED will be RED for up to 3 seconds while internal checks are being carried out inside the bar. After this time, if all operating conditions are normal, the status LED will turn GREEN.









If the status LED does not illuminate GREEN or RED, then check the electrical supply. If the electrical supply is OK, then check the connecting cables for damage.

If the status LED is SOLID RED, then this indicates an overload or other fault:

- Turn the power off and clean the bar.
- Check the electrical supply.
- Check the installation location is as described in this manual.

LED/Signal	Problem	Cause	Action
No LED	No 24 V DC power	<ul style="list-style-type: none">- No supply or voltage too low- Faulty wiring	<ul style="list-style-type: none">- Check supply voltage- Check the wiring
Solid Red	No high voltage at emitter	<ul style="list-style-type: none">- Power supply out of voltage range- Bar overloaded- High voltage supply fault	<ul style="list-style-type: none">- Check power supply voltage- Clean the bar
Flashing Red and Green	Poor ionisation	<ul style="list-style-type: none">- Dirty bar- Bar overloaded- Bar incorrectly positioned	<ul style="list-style-type: none">- Clean the bar- Check positioning of bar- Check emitters for damage

12. Spare Parts and Accessories

Item Picture	Description	Part No.
	3 m cable. M12 female, bare ends. Straight socket.	81193
	5 m cable. M12 female, bare ends. Straight socket.	81194
	7.5 m cable. M12 female, bare ends. Straight socket.	81195
	10 m cable. M12 female, bare ends. Straight socket.	81196
	3 m cable. M12 female, bare ends. 90° socket.	81199
	5 m cable. M12 female, bare ends. 90° socket.	81200
	7.5 m cable. M12 female, bare ends. 90° socket.	81201
	10 m cable. M12 female, bare ends. 90° socket.	81202

12. Spare Parts and Accessories

Item Picture	Description	Part No.
	Universal AC-DC power supply: 100 - 250 V AC, 24 V DC output. Fitted with 1.5 m of cable.	NEOS- PSU
	Mounting 'T' Bracket (40 mm), including flanged nuts.	34208
	Replacement Emitter	34201
	Replacement Emitter Key	342018
	Fraser Ioniser Cleaning Kit: - 500 ml of Cleaning Fluid - Soft bristle hand brush - Instructions for use	81220

This page intentionally blank

This page intentionally blank

For more information about static and to view the full range
of our products, please visit www.fraser-antistatic.com



Scotts Business Park, Bampton, Devon, EX16 9DN, UK
T + 44 (0) 1398 331114 F + 44 (0) 1398 331411
E sales@fraser-antistatic.co.uk W www.fraser-antistatic.com