



NEOS 30 OEM
WITH AUTOMATED RANGE CONTROL



Fraser static control equipment has been designed to give you many years of productive service. However, the science of static control has unique rules which must be followed to allow the equipment to give a good return on your investment.



Please read the following operating and maintenance instructions carefully.

| Contents | Page |
|---|-------------|
| 1 Introduction | 4 |
| 2 Safety | 5 |
| 3 Use | 6 |
| 4 Checking on Delivered Equipment | 6 |
| 5 General Specification and Dimensions | 7 |
| 6 Positioning | 8 |
| 7 Operation and Control | 9 |
| 8 Mechanical | 18 |
| 9 Maintenance | 18 |
| 10 Certification and EU Declaration of Conformity | 19 |
| 11 Troubleshooting | 19 |
| 12 Spare Parts and Accessories | 20 |

1. Introduction

This manual applies to the NEOS 30 OEM Static Eliminator Bar supplied from December 2018.

It is essential that you read and understand the complete manual before installing and using this equipment. This is important for safety and for warranty cover.

1.1 Explanation of Symbols

Warning!

This symbol appearing in the operating instructions refers to operations which, if carried out improperly, may result in serious personal injuries.



Caution!

This symbol appearing in the operating instructions refers to operations which, if carried out improperly, may result in damage to property.



2. Safety

Warnings:

- The Anti-Static Bar is only designed for neutralising surfaces with an electrostatic charge.
- Electrical installation must only be carried out by suitably qualified personnel.
- Adequate installation earth / ground is required to ensure safe and proper operation.
- The 0 V return of the 24 V DC electrical supply must be earthed.
- Disconnect the power supply before cleaning or handling the Bar.
- The emitters are sharp and can cause physical injury.
- There are no user serviceable parts inside the Bar.
- Ensure the Bar and connecting cable are free from damage prior to installation and check periodically once in use.
- Bar must be switched off before removing or connecting the signal cable.
- A small amount of ozone will be produced as part of the ionisation process. When installed correctly the level of concentration of ozone is less than 0.1 ppm and is within internationally accepted limits.



Any changes to the equipment without written consent of the manufacturer will nullify the warranty and CE certification.

As with all pulsed DC static eliminators, it is possible for the user to receive a small static shock as a result of their body being charged by the bar, and then discharging to a nearby earthed object. This is not dangerous, but may be uncomfortable and cause surprise. It is for this reason that the signal cable must not be removed or reconnected when the Bar is powered.



3. Use

The NEOS 30 OEM is a long range static eliminator designed to neutralise electrostatically charged surfaces at distances between 200 mm and 1500 mm. A signal on the 4 - 20 mA current loop input allows the bar frequency to be varied as distance to the charged material varies, such that optimal electrostatic neutralisation can occur.

Powered by 24 V DC with integrated HV supplies and remote monitoring to check bar function remotely. Connection to 24 V DC is via a standard M12 5-Pin Connector. Connection to 4 - 20 mA current loop signal is via a standard M8 3-Pin connector.

Not suitable for outdoor use.

4. Checking on Delivered Equipment

The equipment leaves our factory in suitable protective packaging. Please check that it is undamaged when it arrives. If there is visible damage contact the Factory or one of our Distributors immediately, before carrying out any installation.

Check that the parts which have been delivered are the same as you have ordered.

Loose Parts: Mounting 'T' pieces and fixings - two for the lengths up to 1m plus one extra mounting bracket for every additional 500 mm.

NEOS 30 OEM: Emitter Key and two spare emitters.

M12 5-Pin Connector and lead(s) or Power Supply Unit
- as per order.

5. General Specification and Dimensions

| | |
|---------------------------|--|
| Power Supply: | Voltage: 24 V DC (21 - 27 V). Current: NEOS 30 OEM 2.5 A DC Max. Connection: M12 5-Pin. A-coded. |
| High Voltage: | NEOS 30 OEM - 30 kV integrated into Bar. |
| Supply Cable: | Low voltage, industry standard M12 5-Pin female connector. |
| Emitters: | Long life, high grade Tungsten. |
| Status indication: | LED Green/Green Flashing = OK Flashing Red = Standby. Red = Fault. Red/Green Flashing = Attention required. |
| Signalling: | OK/Attention Open-Collector outputs with internal 1k5 pull-up resistor. Remote DISABLE input. |
| Environmental: | IP67. Internal use. 0-55 °C Max. Dry: max 70% RH, non condensing. |
| Length: | NEOS 30 OEM available at 600 mm, then 750 mm to 5000 mm in 250 mm steps. |
| Weight: | NEOS 30 OEM - 3.6 kg/m. |
| Mounting: | M6 x 40 mm Fixing Slides and Flange Nut. |
| Approvals: | CE, UL and CB. |

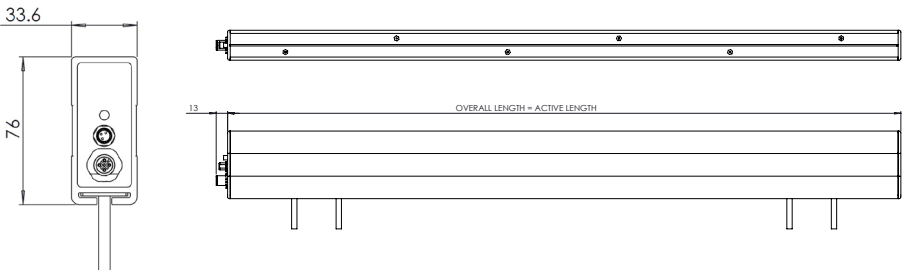

*Note - overall length = order length + 7 mm (including end cap)

6. Positioning

- i. The best location is at, or immediately before, the area where static is causing the problem. Remember that static can be regenerated if the material passes over rollers or through a process after neutralising. A Static Meter is useful to determine the best position.
- ii. Important: Except on a winding reel of material, the material to be neutralised should be in free air, not touching another surface as it passes the Bar. It is not possible to neutralise static electricity where the material is touching another surface or roller.

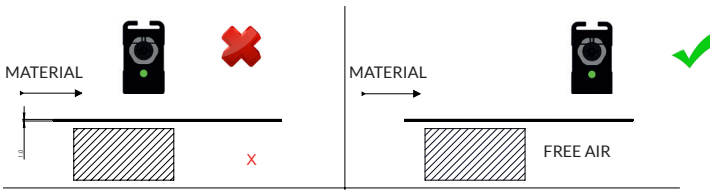

- iii. The Bars must be dry and oil-free.
- iv. It is important that the emitter pins are not touching, or close to metal objects, to avoid spark erosion that will damage both the Bar and the metal object.
- v. The distance from the material should be:
NEOS 30 OEM: 200 - 1500 mm

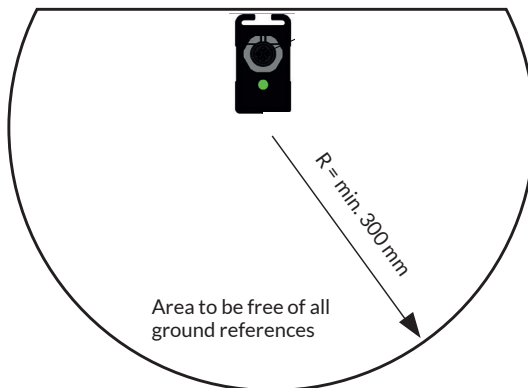

7. Operation and Control

NEOS Automatic Range Control

A 3-pin M8 connector mounted above the M12 connector on the bar is designed for a 4 - 20 mA current loop input signal. This allows the bar output frequency to change as the distance to the charged material changes for optimal electrostatic neutralisation.

HV Output Frequency vs Current Loop Input

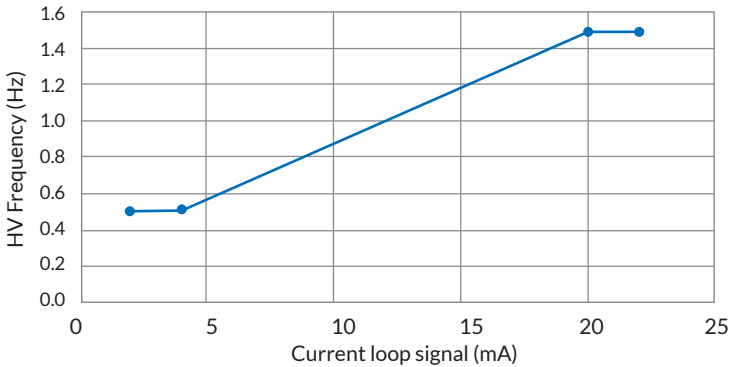

Hardware Specifications

| | |
|---|--|
| Sensing current range | 4 mA – 20 mA |
| Sense (burden) resistance | 250 Ω +/- 1% 5 V drop at 20 mA full-scale |
| Common-mode voltage range (loop compliance) | 0 V – 30 V (up to 6 in series feasible) |
| Input Impedance (common-mode) | >100 k Ω |
| Overload voltage (common-mode, continuous) | 60 V |
| Maximum overload current (continuous) | 30 mA |
| Maximum overload current (<1 s) | 50 mA |
| Connector | M8 male 3-pole |

Firmware Specifications

| | |
|-------------------------------|---|
| Frequency range | 0.5 Hz (4 mA) to 1.5 Hz (20 mA) |
| Frequency tolerance | +/-5% |
| Mapping, frequency to current | Linear |
| Out-of-range error detection | Yes, <2 mA or >22 mA, Frequency saturates at corresponding range. |
| Response time | <1 s |

7. Operation and Control

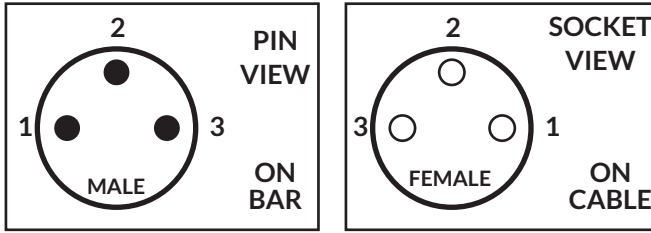

The pin assignment and typical wire colours are given in the table below:

| Pin | Wire Colour | Function | Details |
|-----|-------------|-------------|---|
| 1 | Brown | I in | Current loop input (+) |
| 2* | Black | I out | Current loop output (-) |
| 3 | Blue | 0 V and GND | 0 V / GND, connected internally to power supply 0 V |

*Pin 2 numbered Pin 4 by some cable suppliers

7. Operation and Control

Electrical

Using an existing 24 V DC supply:

The 24 V return must be fitted with

2.5 Amp fuse e.g. Type : 2.5 A, T, 250 V

The 0 V output must be connected to earth.

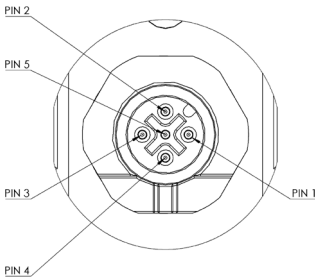
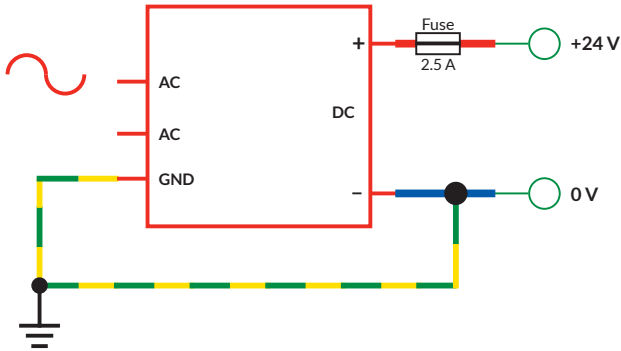

MALE PLUG

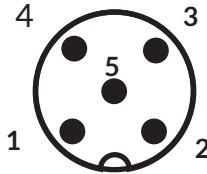

FEMALE SOCKET

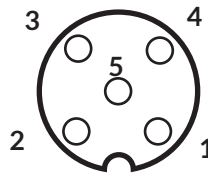

| Pin | Wire Colour | Function |
|-----|----------------------|---------------|
| 1 | Brown | 24 V |
| 2 | White | OK |
| 3 | Blue | 0 V and Earth |
| 4 | Black | Attention |
| 5 | Grey or Green/Yellow | Disable |

7. Operation and Control

Signalling

The NEOS Bars feature two open-collector outputs to enable remote monitoring of Bar status, and a logic-level DISABLE input to allow the HV supplies to be externally disabled when not required (“Standby” mode). For example, the bar can be linked into a machine’s safety interlock system to ensure operator safety during changeover periods.

See wiring diagram and examples below.

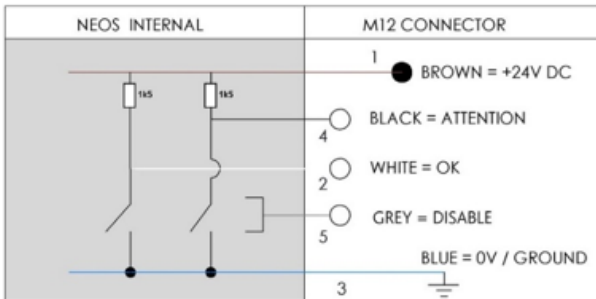
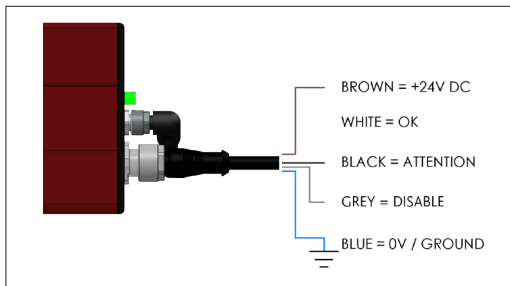

Open-collector outputs (OK, ATTENTION)

Both open-collector outputs are capable of sinking a current of up to 200 mA, allowing direct driving of external lamps or relays, or an external LED with a suitable current limiting resistor. An internal 1k5 pull-up resistor provides a 24V signal suitable for driving a 24V PLC digital input compatible with IEC 61131-2 ‘Type 1’ or ‘Type 3’. See wiring diagram and examples in the next section.

Both output signals are active low, meaning that a signal is asserted by a connection to 0 V via a low-powered solid-state switch. The two signals are valid 5 seconds after power is applied, according to the following conditions:

7. Operation and Control

| Condition | Ionisation | OK (White, Pin 2) | Attention (Black, Pin 4) |
|---|-------------------|---------------------------|---------------------------|
| Bar powered, all OK | ACTIVE (HV ON) | ACTIVE (connected to 0 V) | ACTIVE (connected to 0 V) |
| Bar powered, requires attention (e.g. cleaning) | ACTIVE (HV ON) | ACTIVE (connected to 0 V) | INACTIVE (open-circuit) |
| Bar not powered, overload or hardware fault | INACTIVE (HV OFF) | INACTIVE (open-circuit) | INACTIVE (open-circuit) |
| Standby mode | INACTIVE (HV OFF) | INACTIVE (open-circuit) | ACTIVE (connected to 0 V) |

A working Bar in good operating condition will thus internally connect both open-collector outputs to 0 V, after a delay of up to 5 seconds after power is applied. Voltage applied to open collector outputs must not exceed 28 V DC, and must be of the correct polarity.

The current through the open collector switch must not exceed 200 mA. Failure to limit the current into the open collector outputs may cause permanent damage to the product. Do not connect the open collector outputs directly to 24 V.



7. Operation and Control

Example applications of open-collector outputs

External lamp/indicator

External lamps or indicators can be connected to the OK or ATTENTION outputs to remotely display Bar status. This is useful for bars mounted in inaccessible areas. Lamp rating 24 V DC, maximum 5 W. An LED can also be used with a suitable resistor. Maximum lamp current 200 mA.

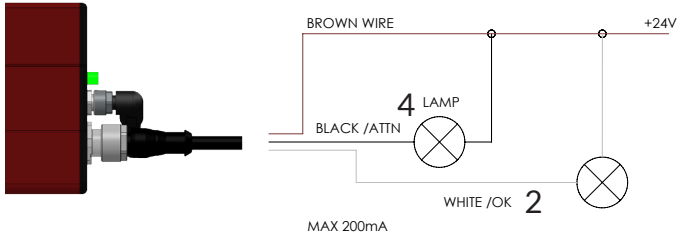

External relay

An external relay can be connected for additional control/feedback applications. Coil rating 24 V, 5 W max.

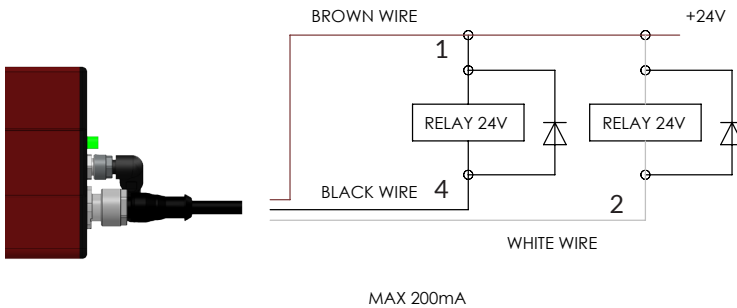

7. Operation and Control

External PLC 'Type 1' or 'Type 3'

Interfacing to an external 24 V IEC 61131-2 'Type 1' or 'Type 3' PLC digital input can be achieved by direct connection.

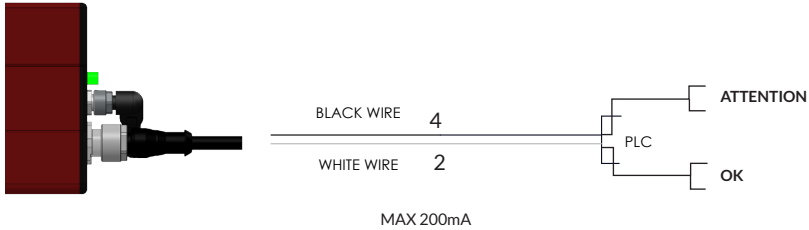

External PLC 'Type 2'

A voltage signal suitable for interfacing with a 24 V IEC 61131-2 'Type 2' PLC input or other 24 V control system can be obtained using an external pull-up resistor to 24 V.

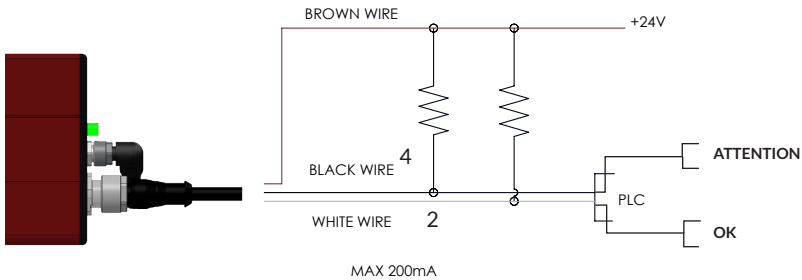

7. Operation and Control

Remote DISABLE input

The NEOS Bars feature a remote DISABLE input signal (Grey or Green/Yellow wire). This may be useful for installations in which the Bar is not used continuously and it is desirable that the Bar should be inactive when not required, or in installations in which the operation of the Bar is to be interlocked with other machinery.

The HV supplies may be externally disabled (Standby mode) by applying any DC voltage between 3 V and 28 V to the DISABLE input, for example by using an external switch or relay contact between the DISABLE input and 24 V, or a logic-level voltage signal. Subsequently reducing the voltage at the DISABLE input to less than 0.5 V restores normal operation of the Bar.

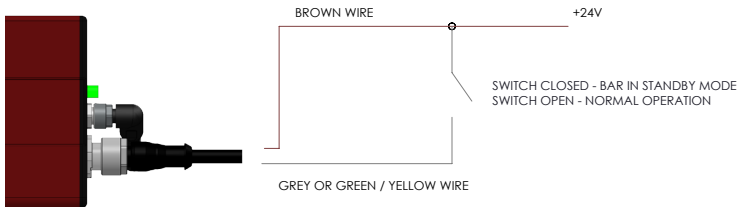

In Standby mode the Bar internal HV supplies are disabled, the status LED flashes red, and the OK output is inactive (open circuit) to indicate that ionisation is disabled. The DISABLE signal has a weak internal pull-down resistor, thus if the DISABLE signal is left disconnected the Bar should operate normally. However, for added noise immunity it is recommended that the DISABLE input is externally connected to 0 V (blue wire) if not required.

Voltage applied to the DISABLE input must not exceed 28 V DC, and must be of the correct positive polarity. The Bar may be permanently damaged by connecting the DISABLE input to any voltage outside the range of 0 V to 28 V DC.

Where the optional SPX - 0724 AC Power Supply has been ordered ensure the Power Unit is connected to 3 wire AC mains supply, Live + Neutral + Ground, and that extra Earth wire from power supply is bonded to Ground. With this optional supply an interface cable is required to access the remote monitor feature.



7. Operation and Control

LED



| Bar State | LED State | LED State (Intelligence Active) |
|-----------------------|-------------|---------------------------------|
| Normal NEOS 30 OEM | Pulse Green | Rapid Flash Green |

IONISATION ACTIVE IN THIS STATE



| Bar State | LED State | Cause | Action |
|-----------|---------------------------|------------------------------------|--|
| Attention | Red/Green Alternate Flash | - Dirty Bar or abnormal conditions | - Clean Bar - Check Installation - Check Process |

IONISATION ACTIVE IN THIS STATE



| Bar State | LED State | Cause | Action |
|-----------|--------------|---|---|
| Fault | Solid Red | - Power supply not within 21 - 27 V - Internal fault - Overload | - Check power supply - Check input voltage - Check HV at pins - Check Bar is correctly wired - Check Bar is correctly positioned. |
| Standby | Flashing Red | - DISABLE signal active (3-28 V) | |

IONISATION NOT ACTIVE IN THIS STATE

8. Mechanical

Versatile mounting 'T' pieces slide into slot at the bottom of the Bar.

Two mounting slides for Bars up to 1 m, plus extra mounting brackets for each additional 500 mm.



9. Maintenance

Turn off power supply to the Bar before doing any installation or maintenance work.



Cleaning is the only maintenance required. Dirt around the emitters will reduce efficiency and result in unsatisfactory performance.

Our Fraser cleaning kit (Part Number 81220) is ideal for use, alternatively a toothbrush or nail brush can be used. Do not use a wire brush as this could damage the Bar.

The Bar can be washed with soapy water or IPA, but it must be dry around the emitters before turning the power on.

Please note, when handling and cleaning, that the **emitter pins are sharp and care is needed!**

The emitter pins are shockless - there is a large resistor below each emitter reducing the current to a shockless level. However please note that DC current can transfer charge to a body if it is touching or close to an emitter for a longer period. This could give a shock when discharging.



The emitters on NEOS 30 OEM should be replaced every two years. Please use the emitter key supplied with the Bar to remove/replace.

10. Certification and Declaration of Conformity

We declare that this equipment conforms to the Low Voltage Directive, and EMC Directive. It is entitled to display the CE and UL marks.

For further instructions and information, please contact the manufacturer.

11. Troubleshooting

On power-up, the status LED will be RED for up to 3 seconds while internal checks are being carried out inside the bar. After this time, if all operating conditions are normal, the status LED will turn GREEN.

If the status LED does not illuminate GREEN or RED, then check the electrical supply. If the electrical supply is OK, then check the connecting cables for damage.

If the status LED is in SOLID RED, then this indicates overload or other fault:

- Turn the power off and clean the bar.
- Check the electrical supply.
- Check the installation location is as described in this manual.

| LED/Signal | Problem | Cause | Action |
|------------------------|----------------------------|--|--|
| No LED | No 24 V power | - No supply or voltage too low - Faulty wiring | - Check supply voltage - Check wiring |
| Solid Red | No high voltage at emitter | - Power supply out of voltage range - Bar overloaded - High voltage supply fault | - Check power supply voltage - Clean Bar |
| Flashing Red and Green | Poor ionisation | - Dirty Bar - Bar overloaded - Bar incorrectly positioned | - Clean Bar - Check positioning of Bar - Check emitters for damage |

12. Spare Parts and Accessories

| Item Picture | Description | Part No. |
|--|---|----------|
|  | <p>3 m cable M12 female, bare ends. Straight socket.</p> | 81193 |
|  | <p>5 m cable M12 female, bare ends. Straight socket.</p> | 81194 |
|  | <p>7.5 m cable M12 female, bare ends. Straight socket.</p> | 81195 |
|  | <p>10 m cable M12 female, bare ends. Straight socket.</p> | 81196 |
|  | <p>3 m cable M12 female, bare ends. 90° socket.</p> | 81199 |
|  | <p>5 m cable M12 female, bare ends. 90° socket.</p> | 81200 |
|  | <p>7.5 m cable M12 female, bare ends. 90° socket.</p> | 81201 |
|  | <p>10 m cable M12 female, bare ends. 90° socket.</p> | 81202 |

12. Spare Parts and Accessories

| Item Picture | Description | Part No. |
|---|---|----------|
|  | Universal AC/DC power supply: 100 - 250 V AC, 24 V DC output Fitted with 1.5 m of cable. | NEOS-PSU |
|  | Mounting 'T' Bracket (40 mm), including flanged nut | 34208 |
|  | Replacement Emitter | 34201 |
|  | Replacement Emitter Key | 342018 |
|  | Fraser Cleaning Kit <ul style="list-style-type: none"> • 500 ml of cleaning fluid • Soft bristle hand brush • Instructions for use | 81220 |

This page intentionally blank

This page intentionally blank

For more information about static and to view the full range
of our products, please visit www.fraser-antistatic.com



Scotts Business Park, Bampton, Devon, EX16 9DN UK
T + 44 (0) 1398 331114 F + 44 (0) 1398 331411
E sales@fraser-antistatic.co.uk W www.fraser-antistatic.com