

NEOS IONISING BARS

DISTRIBUTOR MANUAL



Contents	Page
Background	2
Introduction to 24V DC Range	3
Key New Features	4
Settings	5 - 7
Performance	7 - 8
Applications	9 - 10
Installation	12 - 13
Mechanical	14
Electrical	15 - 16
Operation/Control	17 - 19
Dimensions	20
Safety	21
Ambient Conditions	22
Summary of Specifications	24
Accessories/Spares	25 - 26

NEOS RANGE - 24V DC STATIC ELIMINATORS

The NEOS range of static eliminators is a major advance in industrial static control technology. Please read the following notes which explain how NEOS Bars work and how your customers can benefit from NEOS technology.

NEOS Bar can measure the electric field from the static charge and respond by emitting more ions of the opposite polarity for a faster and more thorough neutralisation. We are calling this NEOS Intelligence. It can emit up to 10 times more of one polarity, if required.

The benefits to the customer are:

- 1) Faster neutralisation. This can be up to 250% for the NEOS 12 Bar compared to the 3024F Bar. For longer range Bars the improvement is typically 200%.
- 2) No polarity adjustments. When the customer changes material, from say, paper to polythene, the polarity of the static charge may change from positive to negative. NEOS can cope with this without problem.
- 3) Distance adjustments. Distance between Bar and static charge is an important consideration in static control. NEOS Bars can be set at the optimal distance setting when installed and will not have to be adjusted again.
- 4) Automatic or Manual In addition to NEOS Intelligent mode, the Bars can also be operated in a manual mode, as conventional pulsed DC Bars - like 3024L and Jupiter.

1. BACKGROUND TO OUR 24V DC DEVELOPMENT

Ionstorm and Jupiter are both capable of being run with 24V DC, but most customers use an AC supply for them. Industrial requirements have changed in the past 5 years and modern machines use 24V DC rather than 230V/115V AC.

The 3024 Bar was launched in 2011 and became a very important product for us. It gave our customers the benefits of:

- High Performance
- No HT cables
- 24V DC supply
- Compact size with active length same as overall length
- Remote and on-bar monitoring
- Long life Tungsten emitters

Although we offer a 90-250V AC Power Supply as an option, over 95% of 3024 Bars are powered by 24V DC from the machine.

The new NEOS range builds on the success of the 3024, with all the benefits of the 3024, but also meeting the future performance requirements of our customers:

- Intelligent ionisation, giving up to 250% more performance
- "Clean Me" monitoring, to signal to customers that maintenance is needed.

The result is the best range of high performance static eliminators available in our industry.

NEOS RANGE - 24V DC STATIC ELIMINATORS

2. AN INTRODUCTION TO THE 24V DC RANGE

The new range of 24V DC Bars consists of 4 different models.

It is important to understand the relationship between the different models.

The choice between models depends on the size of the charge and the distance between Bar and the charge.

3024

The existing 3024 is still an important part of our 24V DC range.

Available in existing F and L models.

Operating at 10-11kV, it gives excellent performance at a competitive price.



NEOS 12

We could have made the 3024 with intelligence, but it would have needed a bigger profile and would have been more expensive. So we kept the existing 3024 and made the first NEOS Bar work with 12kV in both F and L versions.

There are many applications where the 3024 and NEOS12 can both be used - it will be for the distributor to advise the customer.

The NEOS 12 is about 20% more expensive than the 3024 but offers much more power and the "clean me" feature.

The NEOS 12F operates at 12kV DC and is about 250% more powerful than the 3024F and the NEOS L is about 200% more powerful than the 3024L.



NEOS 20

The NEOS 20 operates at 20kV and is a medium / long range Bar.

It opens a new market sector because there is no equivalent Bar available from our competitors.

The NEOS 20 is slightly more expensive, but considerably more powerful than Ionstorm and will probably replace one Bar Ionstorm systems unless the customer wants to use the output adjustments on the Ionstorm Controller.

Ionstorm will still be available - and will be the right choice for many applications where a multi-Bar system of medium power is required.



NEOS RANGE - 24V DC STATIC ELIMINATORS

NEOS 30

NEOS 30 operates at 30kV and is planned to replace Jupiter. Jupiter will still be available for replacements and special requirements for a short time, but NEOS 30 will generally replace it.

NEOS 30 has double the performance and is more compact than Jupiter. NEOS 30 is more expensive than Jupiter but is considerably lower in price than the SIMCO Thunderion which is the only competition at 30kV.



3. KEY NEW FEATURES WITH NEOS

The two new features with NEOS Bars are “Intelligence” and the “Clean Me” signal. It is important to understand how these work and the bene-fits which they give.

Understand how NEOS intelligence gives market leading performance.

It is important to understand how NEOS works so that you can offer the best advice to customers. NEOS Bars can operate intelligently and they can also operate as standard pulsed DC Bars.

NEOS works by measuring the electric field. Measuring the electric field of the static charge is difficult because the strength of the field depends on two factors:

- 1) the voltage level of the static charge in the product.
The higher the voltage, the easier it is to measure and the more attraction power in the product to “suck- in” ions of the opposite polarity.
- 2) distance between static eliminator and static charge.
The longer the distance, the weaker the field.

People with experience of static control applications and pulsed DC products know these factors well. We must stress that these factors are very important in understanding how effectively NEOS technology works. If the static voltage is low and at a long distance, then the NEOS Intelligence will not be able to measure the field because it is too weak. In this case the Bar will operate like a normal pulsed DC Bar - there are three manual settings in addition to the NEOS settings to allow the operator to optimise performance when in normal pulsed DC mode. See later for information on manual settings.

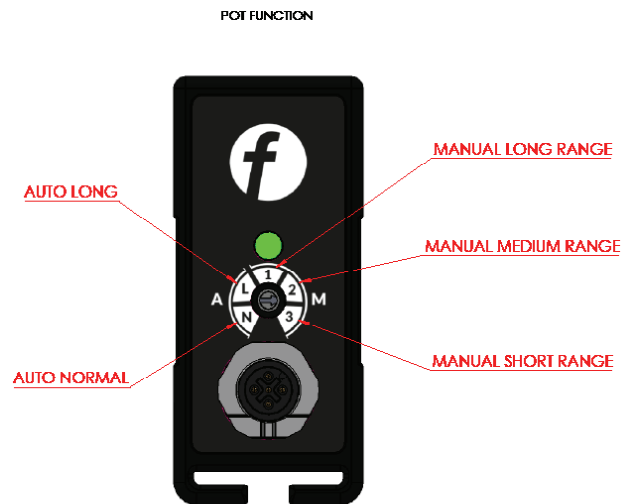

The examples and setting which are given on the following pages are for a 20kV static charge. 20kV is not very high, for higher voltages the effective distances will be much longer.

There are two automatic and three manual settings on the endcap of each NEOS Bar - this is shown on the endcap illustration.

NEOS RANGE - 24V DC STATIC ELIMINATORS

Automatic settings

Auto Normal (AN)

This is the factory setting. It will provide intelligent neutralisation for most applications within the normal operating distances. See chart below

Auto Long (AL)

Auto long can be chosen if the static charge is mostly at the longer end of the operating range of the Bar. At this longer distance the electric field is weaker and so more difficult to measure. Auto Long increases the sensitivity of the NEOS measuring process so that it can respond with better neutralisation for these longer distances. See chart below.

This chart is for a static charge of 20kV. It shows the best distance for each NEOS Intelligence setting. For higher static levels the distances will be much longer. Please note that there is a considerable overlap between the settings.

	Auto Normal (AN)	Auto Long (AL)	Approx. Point where AL is better.
NEOS 12 F	40 to 150mm	100 to 250mm	125mm
NEOS 12 L	100 to 300mm	150mm to 600mm	250mm
NEOS 20	200 to 400mm	300 to 700mm	350mm
NEOS 30	250 to 500mm	300 to 750mm	450mm

The above chart does not consider the neutralisation power of each Bar. If the object is, say, 400mm from the static eliminator NEOS 12L, NEOS 20 or NEOS 30 could be suitable. The choice depends on factors like the size of the static charge, the speed of the process and the nature of the material to be neutralised. This is where distributor knowledge and experience will be important in giving advice. The distributor will already have to meet this when choosing between pre-NEOS Bars - 3024L, Ionstorm and Jupiter.

NEOS RANGE - 24V DC STATIC ELIMINATORS

Manual Settings

NEOS Intelligence provides new levels of static elimination performance. The NEOS Bars can act like normal pulsed DC static eliminators - not using NEOS Intelligence. In this manual mode there are three settings each with a different frequency.

Why are manual settings needed?

- 1) For use where the electric field is too weak, as discussed on previous pages.
- 2) If there is more than one static charge which can be measured. For example, if large mouldings are on a conveyor there is a chance that the NEOS measurement will be of the conveyor, rather than the moulding. Or if two materials are separating and one has a negative charge and one has a positive charge - here a mixed polarity from a manual setting may be better.

There are three manual settings with frequencies for long, medium and short distances. See table below for actual frequencies.

Manual 1. (M1)

This is a long distance setting - for longer distances than AL can reach.

Manual 2. (M2)

This is a medium distance setting - for average distances in above table.

Manual 3. (M3)

This is for the shorter distances in the above table.

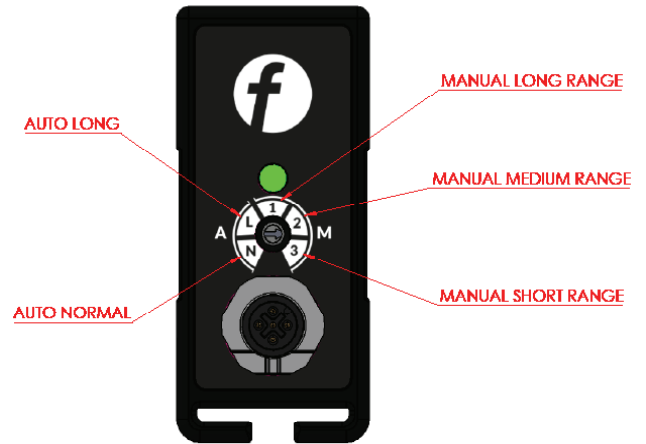

	M1	M2	M3
NEOS 12F	5Hz	20Hz	50Hz
NEOS 12L	1Hz	2Hz	5Hz
NEOS 20	1Hz	2Hz	5Hz
NEOS 30	0.5Hz	1Hz	5Hz

NEOS RANGE - 24V DC STATIC ELIMINATORS

NEOS Controls SUMMARY

- | | |
|----------------------------|---|
| AN = Auto Normal. | Factory default setting which will be suitable for most applications. |
| AL = Auto Long. | More sensitive measurement for longer distances than AN. |
| M1 = Manual Long Range . | Intelligence turned off. For longer distances. |
| M2 = Manual Medium range. | Intelligence turned off. For medium distances |
| M3 = Manual Shorter range. | Intelligence turned off. For shorter distances. |

There is considerable overlap between settings. The graphic below shows a-typical power distribution
Important: turn off the Bar before adjusting the rotary setting switch.

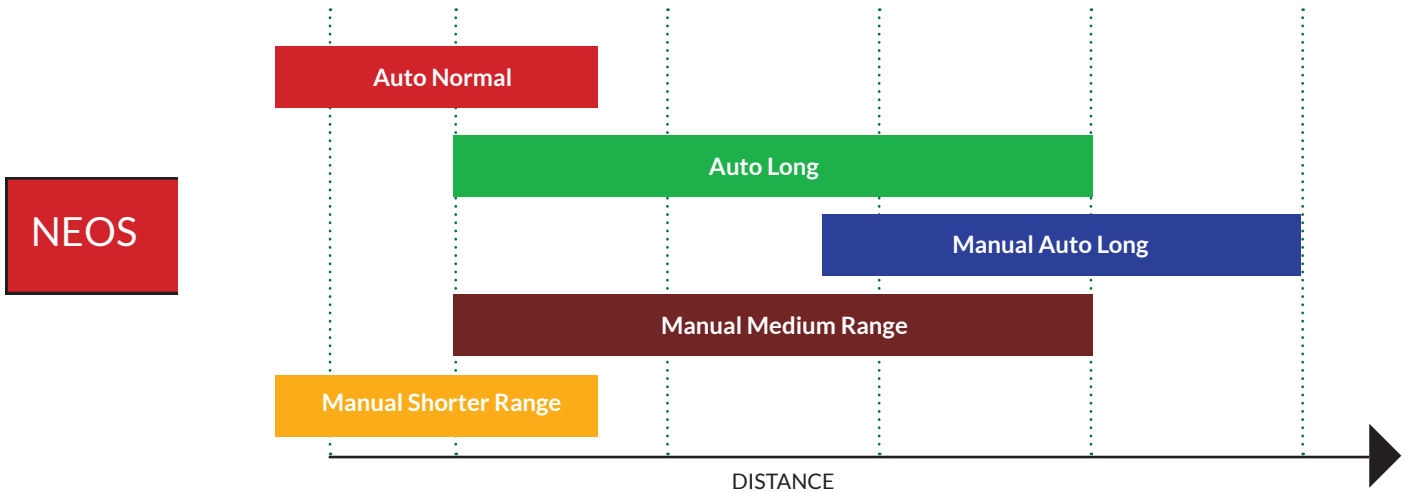

4. PERFORMANCE OF NEOS BARS

It is not possible to measure the performance of NEOS intelligence on standard test equipment for two reasons:

- 1) Normal charge plate monitors only measure decay performance from 5kV. This is much too low for powerful long range static eliminators. We use 20kV as a minimum, or 50kV where necessary.
- 2) The high power of the NEOS Bar will generally neutralise the charge plate before the intelligence has started. So you are measuring the manual setting rather than the automatic setting.

Please be aware of this. Customers or competitors will not be able to measure the performance of NEOS Intelligence on standard test equipment.

We had to build special computerised test equipment for NEOS Bars. This is shown in photo below:



The test equipment for NEOS.

With a plate capacitance of 1130pF (56 times more than the standard charge plate monitor)

It is fully computerised so that many tests per minute can be undertaken.

It delays the measurement to allow the NEOS measurement to turn on - this is about 2 seconds after the high voltage is turned on.

NEOS RANGE - 24V DC STATIC ELIMINATORS

The tables below show the comparative performance measured on the Fraser test equipment. They show the time taken in seconds to reduce the charge plate from 20kV to 2 kV at various distances. Please note that the plate capacitance of 1130pF is many hundred of times higher than for normal statically charged material. This information shows the relative power of each NEOS Bar and relative performance at each distance.

Short range Tests

Distance in mm	50mm	100mm	150mm	200mm
3024F	0.3s	1.2s	3.8s	9.2s
NEOS 12F (AN setting)	0.12s	0.35s	2.9s	8.1s
NEOS 12F (AL setting)	0.14s	0.45s	1.0s	1.9s

NEOS 12F (AN) is 250% more powerful than 3024F at 50mm.

Longer Range Tests

Distance in mm	200mm	300mm	400mm	500mm
3024L	3.5s	9.0s	20.0s	
Ionstorm HP	2.9s	6.9s	14.0s	24.5s
NEOS 12L (AN)	1.7s	7.0s	18.0s	35.0s
NEOS 12L (AL)	1.9s	5.0s	15.7s	29.0s
NEOS 20 (AN)	0.9s	2.1s	7.2s	16.5s
NEOS 20 (AL)	1.0s	2.3s	5.3s	10.6s
Jupiter		2.6s	5.3s	9.3s
NEOS 30 (AN)		1.3s	3.0s	6.2s
NEOS 30 (AL)		1.4s	2.7s	4.7s

NEOS RANGE - 24V DC STATIC ELIMINATORS

5. APPLICATIONS

The applications for NEOS Bars are the same as for the existing 3024, Ionstorm and Jupiter Bars.

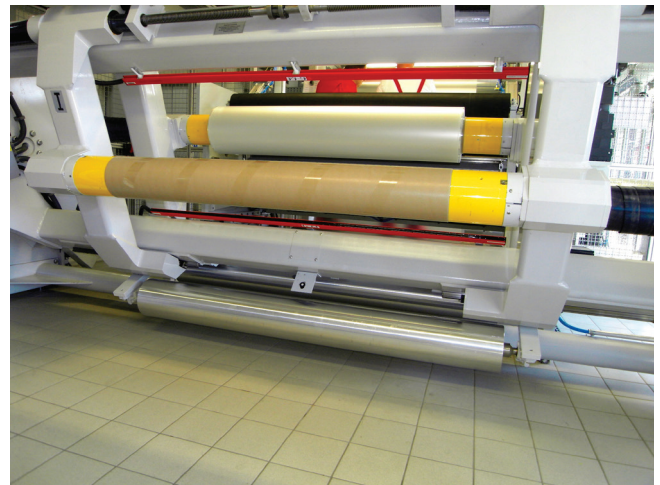
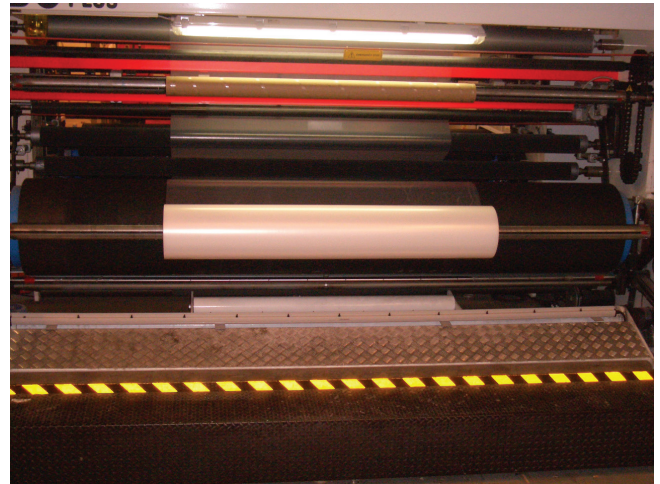
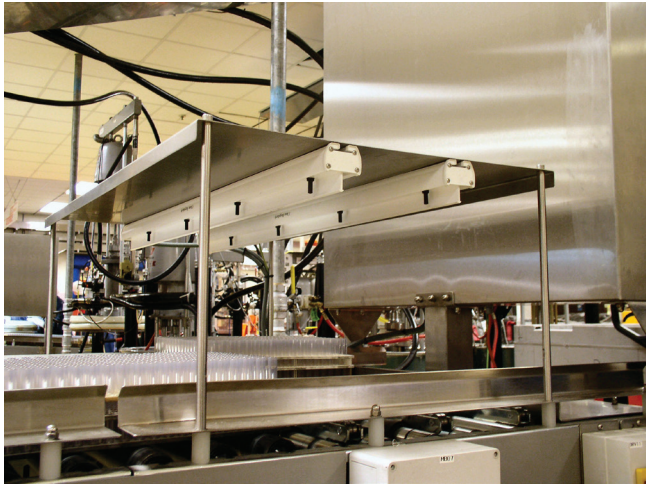

NEOS RANGE - 24V DC STATIC ELIMINATORS

3024L Bars on Winders

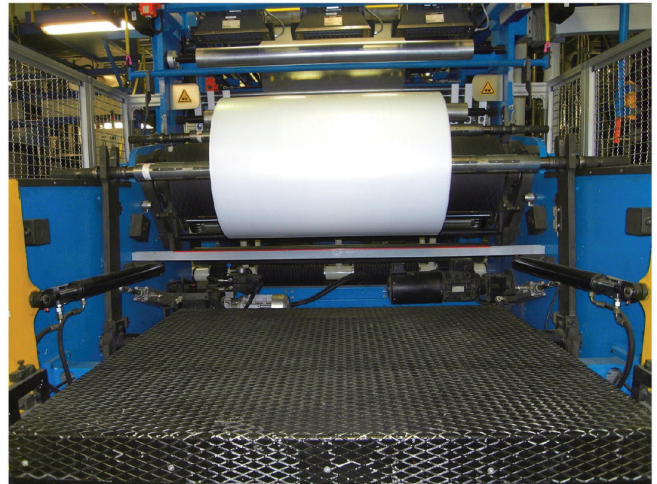
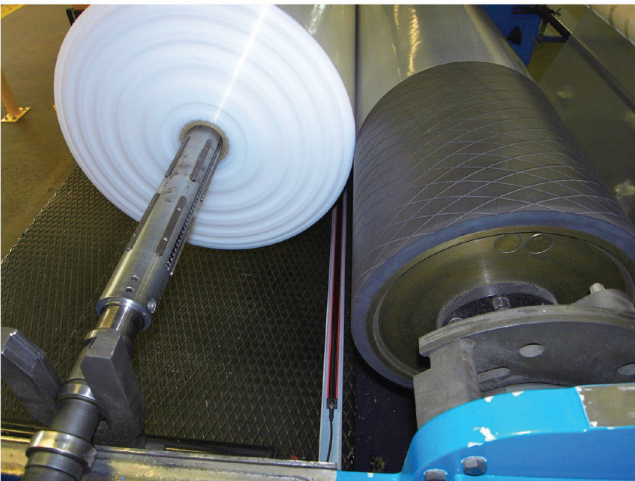
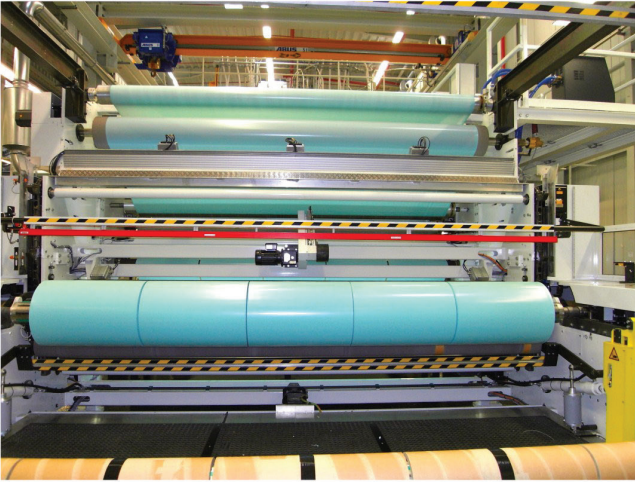

NEOS RANGE - 24V DC STATIC ELIMINATORS

NEOS “Clean Me” Feature

Dirt and abnormal loading conditions are detected by the on-board computer measurement system and this state is signaled both via the end-cap LED and through a dedicated remote signaling conductor within the 5-pin control cable suitable for interface to remote indicators, PLC systems to indicate the Bar needs maintenance attention.

The “Clean Me” requirement is indicated by the end-cap LED flashing red and green. The re-mote signal does not distinguish between “Clean Me” and other fault signals, so if the fault signal is indicated the first thing for the customer to check is whether the LED is flashing red or red and green.

If it is red and green, then it is “Clean me”; if it is red then it is a voltage supply, or other fault.

Please see page 24 which gives further information on remote and local signals.

Abnormal loading can also trigger the “Clean Me” feature. If the Bar is very close to an earthed cross-rod on the machine this could pull extra current without the Bar being dirty. In this case, the Bar should be positioned away from the crossrod which is attracting the ions from the Bar.

NEOS RANGE - 24V DC STATIC ELIMINATORS

6. INSTALLATION

- The best location is at, or immediately before, the area where static is causing the problem. Remember that static can be regenerated if the material passes over rollers or through a process after neutralising. A Static Meter is useful to determine the best position.
- Important: Except on a winding reel of material, the material to be neutralised should be in free air, not touching another surface as it passes the Bar. It is not possible to neutralise static electricity where the material is touching another surface or roller.

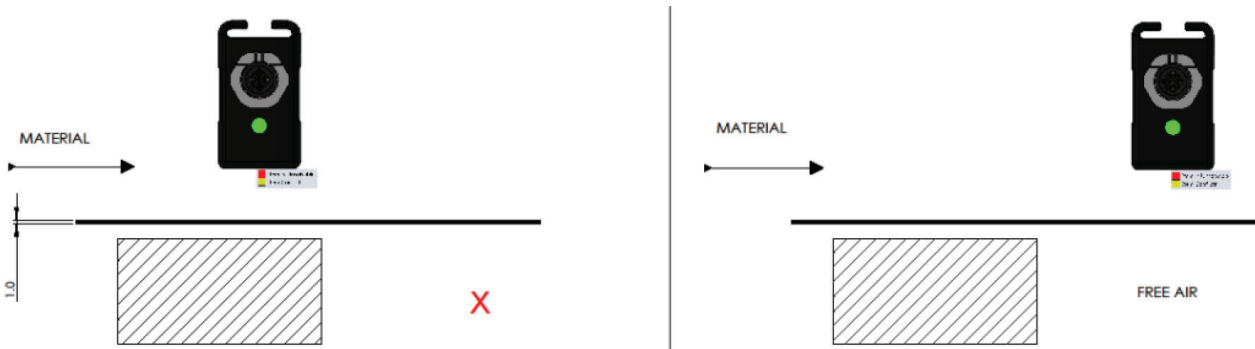

- The Bars must be dry and oil-free
- It is important that the emitter pins are not touching, or close to metal objects, to avoid spark erosion that will damage both the Bar and the metal object.
- The distance from the material should be:
NEOS 12F: 30 - 300mm
NEOS 12L: 100 - 600mm
NEOS 20: 150 to 750mm
NEOS 30: 300 - 1000mm

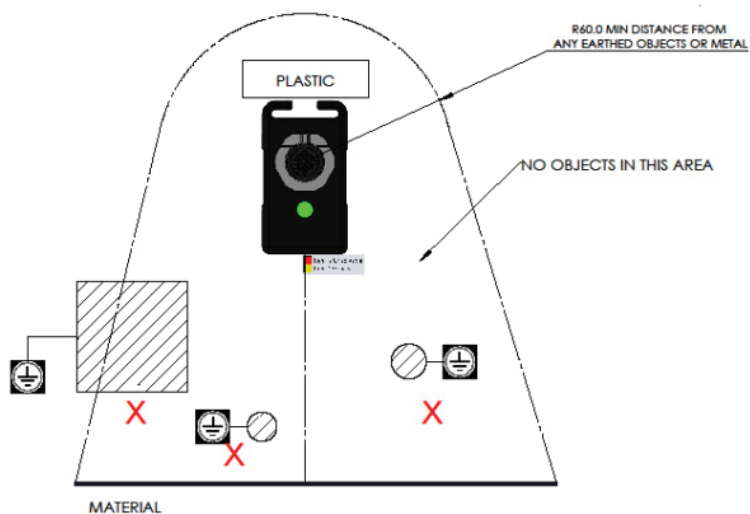

NEOS RANGE - 24V DC STATIC ELIMINATORS

Installation Cont.

- Versatile 'T' brackets slide into slot at the bottom of the Bar.
- M6 x 40mm long studs. Two mounting 'T' pieces for Bars up to 1m, then an extra 'T' piece for every additional 500mm.
- Other stud lengths are available, contact the factory for options.
- Bars over 1m long should be supported in the middle in addition to at each end. Bars over 2m should have two middle supports in addition to the end supports.
- In the unlikely case that two Bars are required, one on each side of a material, they should be offset by at least 60mm.
- Distance "B" should be at least 60mm.
- This is the same as with a 1250-S Bar.

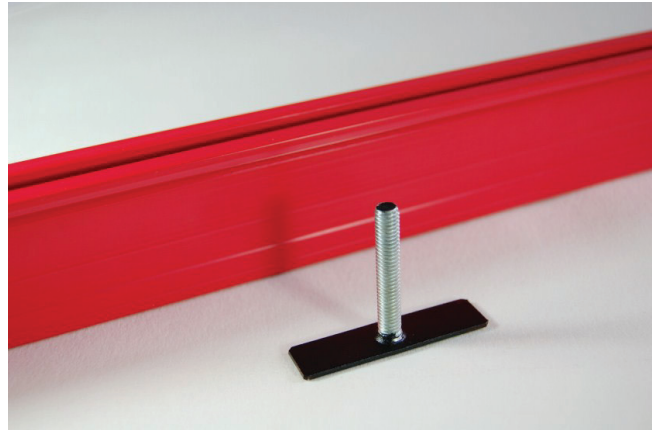

NEOS RANGE - 24V DC STATIC ELIMINATORS

Construction, Body and Mechanical Parts

The extruded body is made from a UL grade flame resistant ABS. The black endcaps are a similar FR-ABS injection moulding grade.

The electronics are encapsulated in epoxy resin for protection and to give the product the ability to withstand tough treatment. The epoxy is a specially formulated resin which is resistant to ozone and UV light, both of which are produced by all ionising emitters.

Emitters are made from pure tungsten which will give many years of high performance ionisation.

The water and dust protection level is IP67.

NEOS RANGE - 24V DC STATIC ELIMINATORS

8. Electrical

Using an existing 24V DC supply:

The 24V output must be fitted with:

NEOS 12F and NEOS12 L: 1.5 Amp fuse e.g. Type: 1.5 AT 250V

NEOS 20: 2.0 Amp fuse e.g. Type : 2.0 AT 250V

NEOS 30: 2.5 Amp fuse e.g. Type : 2.5 AT 250V

The 0V output must be connected to earth.

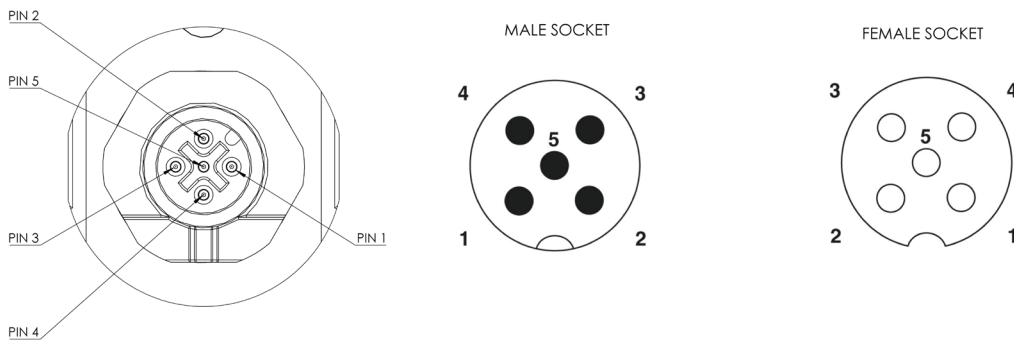
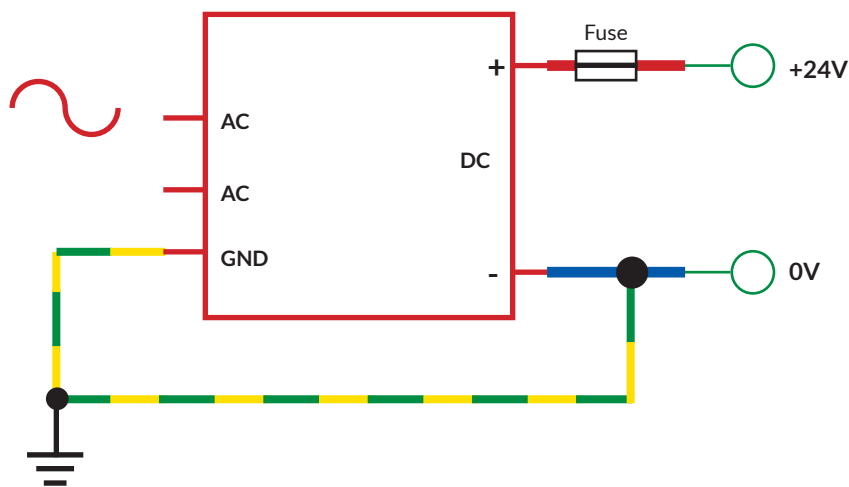

IMPORTANT: Cable colours may change or the individual cables may be numbered instead of coloured. Please use the cable number in the chart below as the main guide, rather than colour

Pin	Colour	Function
1	Brown	24V
2	White	OK
3	Blue	0V & Earth
4	Black	Attention
5	Grey	On / Off

This wiring is for the Murr cables which we supply. Other cables may have different colour schemes

NEOS RANGE - 24V DC STATIC ELIMINATORS

Signalling

The NEOS Bars feature two open-collector outputs to enable remote monitoring of Bar status, and a logic-level ON/OFF input to allow the HV supplies to be externally disabled when not required ("Standby" mode).

See wiring diagram and examples below.

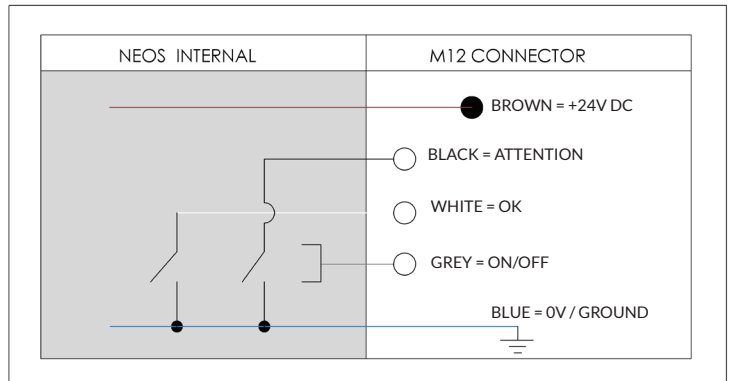
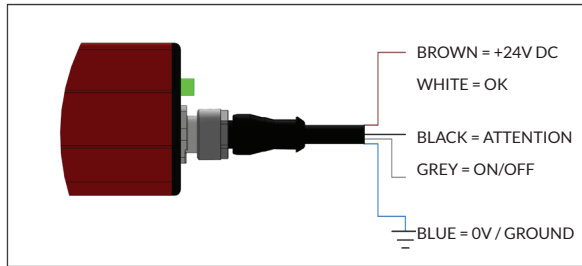

Open-collector outputs (OK, ATTENTION)

Both open-collector outputs are capable of sinking a current of up to 200mA, allowing direct driving of external lamps or relays, or an external LED with a suitable current limiting resistor. An external pull-up resistor may be used to provide a logic-level or 24V signal voltage to a PLC or other destination. See wiring diagram and examples in the next section.

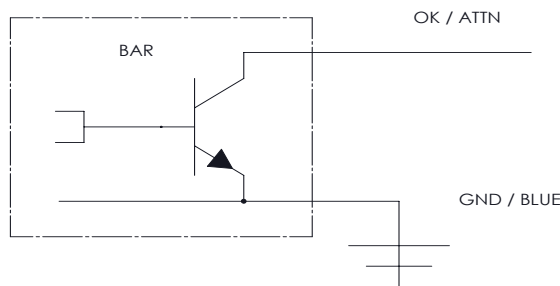

Both output signals are active low, meaning that a signal is asserted by a connection to 0V via a low-powered solid-state switch. The two signals are valid 5 seconds after power is applied, according to the following conditions:

Condition	Ok (White Wire)
Bar Powered and Working	Active (output connected to internal 0V)
Supply out of range, Standby mode, HV supply fault, Overload, Other fault with Bar.	Inactive (open)

NEOS RANGE - 24V DC STATIC ELIMINATORS

9. Operation & Control

Condition	Attention
Bar powered all "OK"	Active (output connected to internal 0V)
Bar powered and dirty or abnormal load	Inactive (output open)
Standby mode (ON/OFF connected to 0V)	Inactive (output open)
Supply out of range, HV supply fault, Overload, Other fault with Bar	Inactive (output open)

A working Bar in good operating conditions will thus internally connect both open-collector outputs to 0V, after a delay of up to 5 seconds after power is applied.

If the open-collector outputs are not required, the black wire and the white wire should be connected to 0V (blue wire).

Voltage applied to open collector outputs must not exceed 28V DC, and must be of the correct polarity.

The current through the open collector switch must not exceed 200mA. Failure to limit the current into the open collector outputs may cause permanent damage to the product. Do not connect the open collector outputs directly to 24V.



Example applications of open-collector outputs

External lamp/indicator

External lamps or indicators can be connected to the OK or ATTENTION outputs to remotely display Bar status. This is useful for Bars mounted in inaccessible areas. Lamp rating 24V DC, maximum 5W. An LED can also be used with a suitable resistor. Maximum lamp current 200mA.

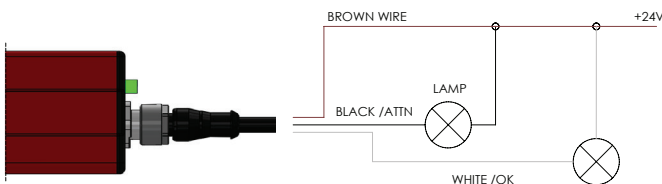

External relay

An external relay can be connected for additional control/feedback applications. Coil rating 24V 5W max.

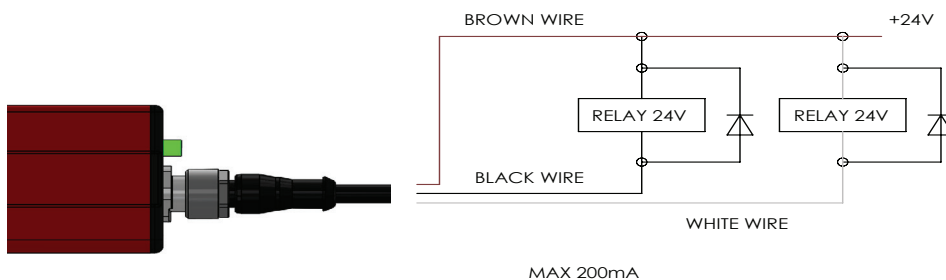

NEOS RANGE - 24V DC STATIC ELIMINATORS

9. OPERATION & CONTROL

External PLC

A voltage signal suitable for interfacing with a PLC or other control system can be obtained using an external pull-up resistor.

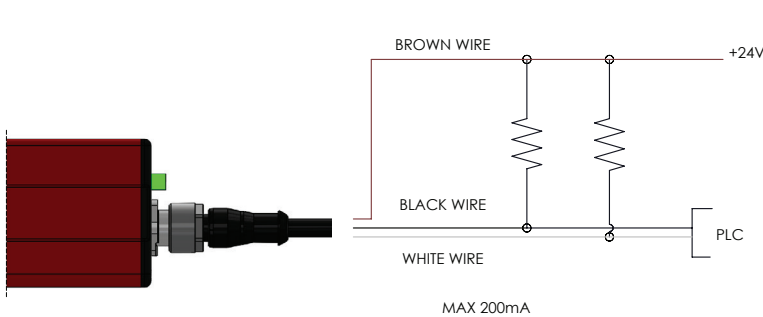

The voltage connected to the external pull-up resistor must correspond to the required high-level plc input voltage, up to a maximum of 28V. If the high-input voltage of the plc is 24V, then the pull-up must be connected to 24V (as shown above). If the input is “logic-level” or “TTL-level”, then the pull-up should be connected to a lower voltage such as 5v.



Remote ON/OFF input

The NEOS Bar features a remote ON/OFF input signal (Grey wire). This may be useful for installations in which the Bar is not used continuously and it is desirable that the Bar should be inactive when not required, or in installations in which the operation of the Bar is to be interlocked with other machinery.

The HV supplies may be externally disabled (Standby mode) by applying any DC voltage between 2V and 28V to the ON/OFF wire, for example by using an external switch or relay contact between the ON/OFF wire and 24V, or a logic-level voltage signal. Subsequently reducing the voltage at the ON/OFF input to less than 0.5V restores normal operation of the Bar.

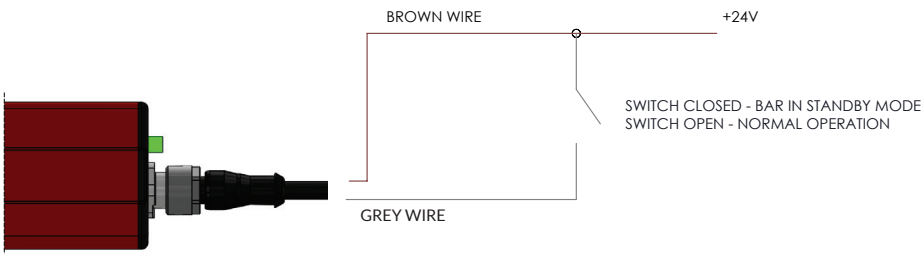

NEOS RANGE - 24V DC STATIC ELIMINATORS

9. OPERATION & CONTROL CONTINUED

Any voltage exceeding 2V on the ON/OFF wire will cause the Bar to enter Standby mode, and any voltage below 0.5V will cause the Bar to operate normally. The ON/OFF input is therefore compatible with 24V and TTL-level signalling.

In Standby mode the Bar internal HV supplies are disabled, the status LED flashes red, and both open-collector outputs are inactive (open circuit).

The ON/OFF signal has a weak internal pull-down resistor, thus if the ON/OFF signal is left disconnected the Bar should operate normally. However, for added noise immunity it is recommended that the ON/OFF input is externally connected to 0V (blue wire) if not required.

Voltage applied to the on/off input must not exceed 28V DC, and must be of the correct positive polarity. The Bar may be permanently damaged by connecting the on/off input to any voltage outside the range of 0V to 28V DC.

Where the optional SPX - 0724 AC Power Supply has been ordered ensure the Power Unit is connected to 3 wire AC mains supply. Live + Neutral + Ground, and that extra Earth wire from power supply is bonded to Ground. With this optional supply an interface cable is required to access the remote monitor feature.

LED

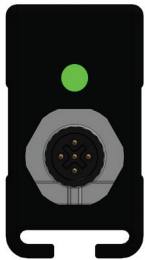

Bar State	LED State	LED State (Intelligence Active)
Auto Normal	Pulse Green	Rapid Flash Green
Auto Long	Double Pulse Green	Rapid Flash Green
Manual 1,2,3	Slow, Medium or Fast flashing depending on the duty/frequency	N/A



Bar State	LED State	Cause	Action
Attention	Red/Green Alternate Flash	- Dirty Bar or abnormal conditions - Bar working but intelligence switched off	- Clean Bar - Check Installation - Check Process

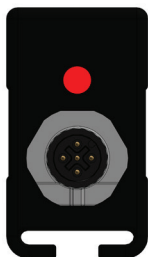

Bar State	LED State	Cause	Action
Attention	Solid Red	- Power Supply not within 21 - 27V - No High Voltage	- Check Power Supply - Check Input Voltage - Check HV at Pins - Check Bar is Correctly Wired - Check Bar is Correctly Positioned.
Standby	Flashing Red	- On/Off Signal Low (0V)	- Check Wiring

NEOS RANGE - 24V DC STATIC ELIMINATORS

10. DIMENSIONS

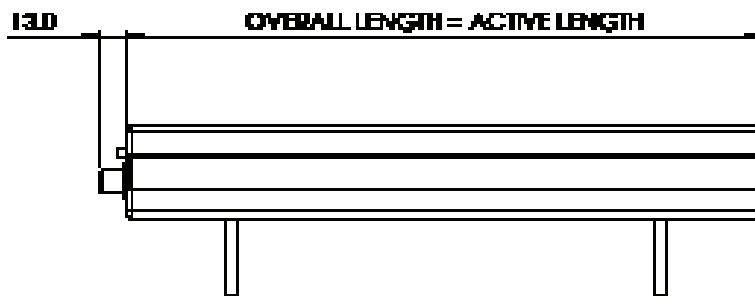
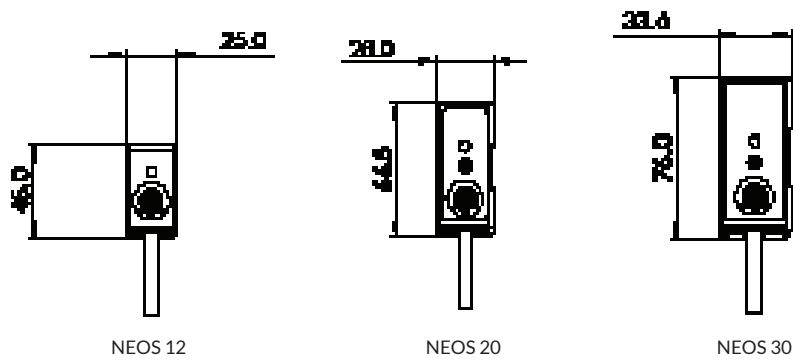

NEOS 12

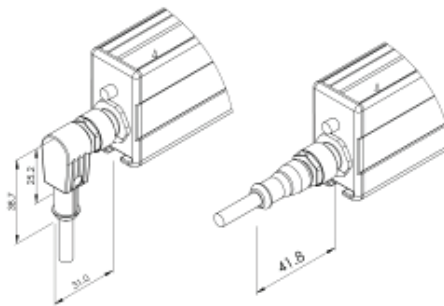

NEOS 20

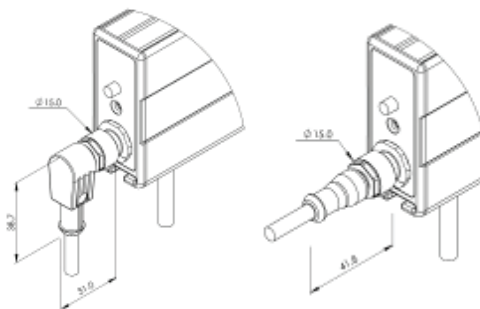

NEOS 30

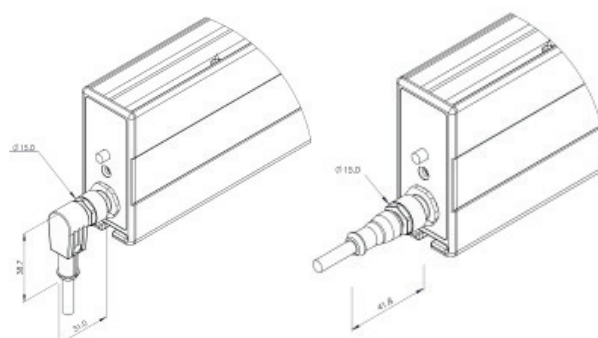

NEOS RANGE - 24V DC STATIC ELIMINATORS

11. MAINTENANCE AND SAFETY

The emitter pins are resistively coupled to the high voltage supply. Each emitter pin has a dedicated resistor value NEOS 12–130mohm, Neos 20–200mohm, Neos 30–260mohm. This means that the emitter pins are shockless to touch. The current at the pin is approximately 90µA.

Note: that if the emitters are connected in parallel, for example by high levels of moisture after washing, then the resistance will be reduced and so the energy level on the emitter pins will be increased. This applies to all resistively coupled static eliminators, not just the Neos. Ensure that the Bar is dry before turning on power.

The negative and positive voltages are not “ON” at the same time.

There is input power limitation.

There is full voltage regulation and overload protection in the electronic circuitry.

The emitter pins are sharp - care is required when handling and cleaning them.

The emitters on NEOS 20 and NEOS 30 should be replaced every two years. Please use the emitter key supplied with the Bar to remove/replace.

Ozone: all high voltage equipment produces ozone. The ozone emission from Neos Bars is less than 0.1 ppm and meets international standards.

Cleaning:

The Neos Bar should be kept clean for optimal performance. A layer of dirt will allow current to flow to earth instead of being used to produce ionisation.

Physical impurities on the emitter pins will work against ionisation.

Dust can be removed with a nylon (or other plastic) brush - such as a tooth-brush. Stubborn dirt may be removed by a solvent, such as IPA, or other clean-ing liquid which is compatible with ABS and epoxy resin.

The IP67 construction of the Neos allows liquids to be used in cleaning the Bars and allows the Bars to be used in food and similar applications where there are “wash-down” procedures. In these cases it is important that the power to the Bar is switched OFF before cleaning or maintenance work and that the Bar is dry before switching power ON.

Where washing is required it is important that the Bar is positioned so that water cannot collect around the emitter pins - they should face downwards.

As mentioned above, if water is present around the emitter pins the Bar will no longer be shockless as the current limiting resistors be low each pin will be connected in parallel and so have a lower resistance.

NEOS RANGE - 24V DC STATIC ELIMINATORS

12. OPERATIONAL CONDITIONS

Class: Indoor, industrial use.
Temperature : 0°C to 55°C maximum.
Humidity : Maximum 70% rH, non-condensing.

On power-up, the status LED will be RED for up to 3 seconds while internal checks are being carried out inside the Bar. After this time, if all operating conditions are normal, the status LED will turn GREEN.

If the status LED does not illuminate GREEN or RED, then check the electrical supply. If the electrical supply is OK, then check the connecting cables for damage.

If the status LED is RED, then this indicates overload or other fault:

Turn the power off and clean the Bar.

Check the electrical supply.

Check the installation location is as described in this manual.

LED/Signal	Problem	Cause	Action
No LED	No High Voltage at Emitter	- No supply or voltage - Faulty wiring	- Check supply voltage and range - Check Wiring and Voltage
Solid Red	No High Voltage at Emitter	- Power supply out of range - Bar overloaded - High voltage supply fault	- Clean Bar - Check Power Supply Range and Volt-age
Flashing Red and Green	Poor Ionisation	- Dirty Bar - Bar overloaded - Bar incorrectly positioned	- Clean Bar - Check posi- tioning of Bar - Check emitters for damage

NEOS RANGE - 24V DC STATIC ELIMINATORS

12. UL AND CB CERTIFICATION

Meeting international safety standards is important and customers are not always happy to accept certification which has been made by the manufacturer. They want third party certification.

The international safety standard used for static eliminators is IEC60950, which is the unified standard for IT equipment.

Low Voltage Directive: 2006/95/EC. EMC Directive: 2004/108/EC

We have had the Neos Bar Range externally certified for UL and CB. UL certification covers USA and Canada; CB is the international product passport for industrial countries run by the IEC, see: <http://www.iecee.org/>.

It is unlikely that many of our competitors have this level of safety certification so is an important sales point, especially for machinery manufacturers.

NEOS RANGE - 24V DC STATIC ELIMINATORS

SUMMARY SPECIFICATION: NEOS RANGE

	3024	NEOS 12	NEOS 20	NEOS 30
Power Supply	24V DC (21-27V). Current: 1A max	24V DC (21-27V). Current: 1A max	24V DC (21-27V). Current: 1A max	24V DC (21-27V). Current: 1A max
High Voltage:	10-11 kV	12kV	20kV	30kV
Supply cable:	Low voltage, M8, 4 pin	Low voltage, M12, 5 pin	Low voltage, M12, 5 pin	Low voltage, M12, 5 pin
Emitters:	Long life tungsten 3024 F: 25mm pitch. 3042 L: 50mm pitch,.	Long life tungsten Neos12 F: 30mm pitch. Neos12 L: 60mm pitch.	Long life tungsten. 75mm pitch, replaceable	Long life tungsten 100mm pitch, (600mm only) 125mm Pitch standard replaceable
Status indication:	LED. Green = OK. Red = fault or dirty Bar. Remote Monitor—see page 9.	LED. Green = OK. Red = fault or clean me. Green red flash Remote Monitor—see page XX.	LED. Green = OK. Red = fault or clean me. Green red flash Remote Monitor—see page XX.	LED. Green = OK. Red = fault or clean me. Green red flash Remote Monitor—see page XX
Environmental:	IP67. Internal, industrial use. 0-55°C. Dry: max 70% rH,	IP67. Internal, industrial use. 0-55°C. Dry: max 70% rH, non condensing.	IP67. Internal, industrial use. 0-55°C. Dry: max 70% rH, non condensing.	IP67. Internal, industrial use. 0-55°C. Dry: max 70% rH, non condensing.
Length:	Effective length = 100% of overall length. Overall length is Order length +6mm	Effective length = 100% of overall length. Overall length is Order length +6mm NEOS 12F: Min length 300mm then steps of 60mm to 4.98m NEOS 12L: Min length 360mm then steps of 120mm to 4.92m	Effective length = 100% of overall length. Overall length is Order length +6mm NEOS 20 Min length 450mm then steps of 150mm to 4.95m	Effective length = 100% of overall length. Overall length is Order length +6mm NEOS 30 Min length 600mm then steps of 200mm to 5m
Height and Width	41.5mm x 22mm	45mm x 25mm	66.5mm x 28mm	76mm x 33.6mm
Weight:	1.1 kg/m.	1.5 kg/m.	2.5 kg/m.	3.6kg/m.
Mounting:	Low profile mounting slide	Low profile mounting slide	Low profile mounting slide.	Low profile mounting slide.
Approvals:	CE, UL & CB.	CE, UL & CB.	CE, UL & CB.	CE, UL & CB.

NEOS RANGE - 24V DC STATIC ELIMINATORS



ACCESSORIES AND SPARE PARTS

The M12 5-pin power cables are not included in the price of the Neos Bar. They are an accessory which we supply at a low net price. They are standard DIN M12 x 5-pin wire cable and connectors which are also readily available from Murr, Lumberg, Phoenix etc.

Item Picture	Description	Part No.
	3m cable M12 female, bare ends. 180° connector.	81193
	5m cable M12 female, bare ends. 180° connector.	81194
	7.5m cable M12 female, bare ends. 180° connector.	81195
	10m cable M12 female, bare ends. 180° connector.	81196
	3m cable M12 female, bare ends. 90° connector.	81199
	5m cable M12 female, bare ends. 90° connector.	81200
	7.5m cable M12 female, bare ends. 90° connector.	81201
	10m cable, M12 female, bare ends. 90° connector.	81202

NEOS RANGE - 24V DC STATIC ELIMINATORS

ACCESSORIES AND SPARE PARTS

Item Picture	Description	Part No.
	Universal AC/DC power supply: 100-250V AC, 24V DC output Fitted with 1.8m of cable IEC 320 socket.	342011
	M8 male to M8 female 4-pin extension cable for AC/DC power supply unit. (available in 2m lengths).	
	Mounting 'T' Bracket and flanged nut.	NEOS 12 - 341210 NEOS 20 - 34208 NEOS 30 - 34308