

SOLUTIONS TO STATIC PROBLEMS

PRINTING SCREEN PRINTING



Ionstorm Long Range Bar 3850-HP

Ionstorm Long Range Ionising Bars are positioned 300mm to 600mm above the material and so are suitable for:

- Positioning above the screen to prevent adhesion of the sheet to the screen, and printing problems like fogging and feathering.
- Use above the feedboard to prevent sheet twisting.
- The delivery stack if there is a lot of curl on the sheet.

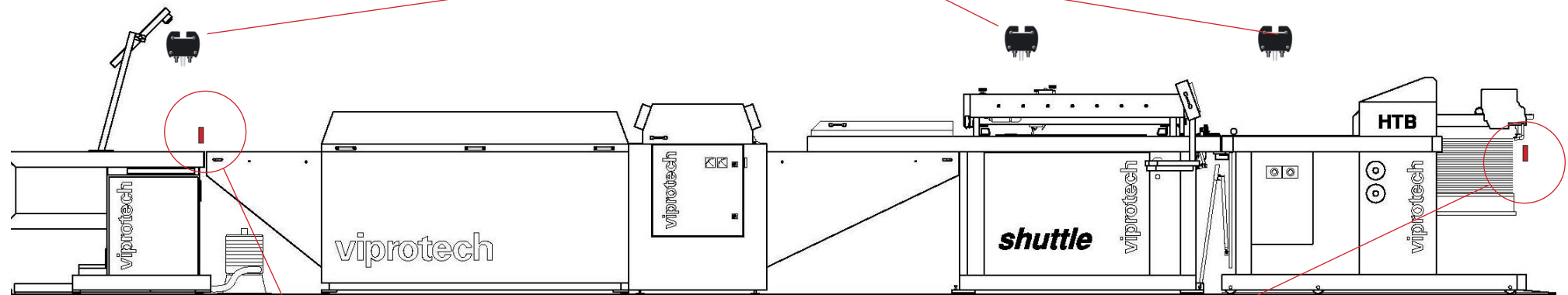

1250-S Ionising Bar

Our powerful 1250-S Ionising Bars are used after the dryer to neutralise the static charge in the sheet.

This allows the sheet to deliver onto the stack without problem. As an alternative an Ionstorm Long Range Bar can be used.

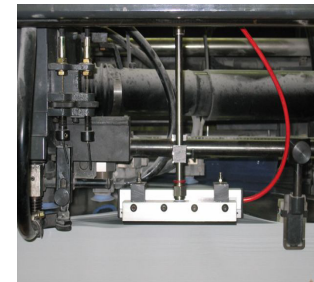

5400 Sheet Separator System

Our adjustable sheet separation system is ideal to prevent multiple sheet pick up on feeders.

It blows ionised air into the top 10mm of the stack to separate the sheets and kill the static charge.

It requires compressed air at 1-2 Bar.