



X-SERIES IONISING BARS
WITH INTEGRATED REMOTE MONITOR



Fraser static control equipment has been designed to give you many years of productive service. However, the science of static control has unique rules, which must be followed to allow the equipment to give a good return on your investment.



Please read the following operating and maintenance instructions carefully.

Contents	Page
1 Introduction	4
2 Safety	7
3 Positioning of the Bar	8
4 Installation	11
5 Electrical Connections	13
6 Status LEDs	16
7 Operation, Maintenance and Safety	19
8 Commissioning	24
9 Maintenance	24
10 Troubleshooting	25
11 Remote Interface and Wiring Examples	26
12 Specification and Dimensions	30
13 Spare Parts and Accessories	33

1. Introduction

The X-SERIES Range of Ionising bars is a family of high performance DC static eliminators from Fraser Anti-Static Techniques. These products are used by leading manufacturers throughout the world to increase safety and productivity.

It is essential that you read and understand the complete manual before installing and using this equipment. This is important for safety and for warranty cover.

Features and Benefits

The Fraser X-SERIES Range of bars is a high-performance family of products designed for short or long-range neutralisation of electrostatically charged surfaces.

Powered by 24 V DC, it features integrated high voltage supplies meaning that no high voltage cabling is required.

X-12 (F & L Versions)



X-20



X-33



1. Introduction



Distance Control: distance-to-target setting.
The status of the bar, including the need for cleaning, is indicated by 3 bi-colour LEDs on the endcap of the bar. Duplicate outputs enable integration with a control system or PLC.

Intelligence Control: Intelligence ON/OFF.
The 24 V DC power supply and remote monitoring connections are made via an M12 5-pin connector.

An external AC-DC PSU can be ordered if 24 V DC is not available.

Mounting onto the machine is with 'T' fixings that slide into the slot in the bar.

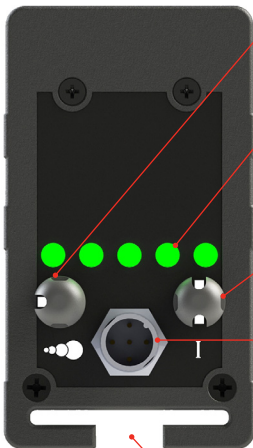

Distance Control: distance-to-target setting.
See Section 7.

The status of the bar, including the need for cleaning, is indicated by 5 bi-colour LEDs on the endcap of the bar. Duplicate outputs enable integration with a control system or PLC. See Section 6.

Intelligence Control: Intelligence ON/OFF.
See Section 7.

The 24 V DC power supply and remote monitoring connections are made via an M12 5-pin connector.
An external AC-DC PSU can be ordered if 24 V DC is not available.

Mounting onto the machine is with 'T' fixings that slide into the slot in the bar.

1. Introduction

Explanation of Symbols

Warning!

This symbol appearing in the operating instructions refers to operations which, if carried out improperly, can result in serious personal injuries.



Caution!

This symbol appearing in the operating instructions refers to operations which, if carried out improperly, can result in damage to property.



Information!

This symbol refers to information that relates to obtaining the best performance and operating life from the product.



Checking on Delivered Equipment

The equipment leaves our factory in suitable protective packaging. Please check that it is undamaged when it arrives. If there is visible damage, contact the Factory or one of our Distributors before carrying out any installation.

Check that the parts which have been delivered are the same as you have ordered.

Loose Parts Bars up to 1,000 mm in length are supplied with two 'T' fixings.
Extra 'T' fixings are supplied for each additional 500 mm or part thereof. For example:

750 mm:	2 'T' fixings
1,500 mm:	3 'T' fixings
1,750 mm:	4 'T' fixings

It is important to use all of the supplied 'T' fixings.

Emitter Key and two spare emitters.

Power Supply Cable. M12 5-pin Connector and lead or Power Supply Unit - as per order. See Section 14 for details of cables and other accessories.

Warning!

DO NOT USE standard 'computer style' PSUs. These do not have secondary earth connections and risk shocks to the operator and damage to the bar. Only use the Fraser external Power Supply Unit (Part No. NEOS-PSU).



2. Safety

The X-SERIES Range of Ionising bars has been designed in accordance with the safety requirements of the EU Low Voltage Directive.

- The emitter pins are resistively coupled to the high voltage supplies. The emitters are a Class 1 electrical energy source. Contact with the emitters is not painful and will not result in electrically-caused injury, but may cause a detectable sensation due to the small current which will flow.
- As with all pulsed DC static eliminators, it is possible for the user to receive a small static shock as a result of their body being charged by the bar, and then discharging to a nearby earthed object. This is not dangerous, but may be uncomfortable and cause surprise.
- The emitter pins of the bar are necessarily sharp. The emitter pins are a Class 2 mechanical energy source. Contact with them may be painful, but will not cause an injury requiring emergency medical attention. Take care when handling the bar.
- Installation and maintenance work on the bar must only be carried out by suitably qualified personnel.
- The negative pole of the 24 V DC supply provided to the bar must be permanently earthed.
- Adequate installation earth/ground is required to ensure safe and proper operation.
- Do not connect or disconnect the M12 cable from the bar while it is powered.
- A small amount of ozone will be produced as part of the ionisation process. When installed correctly the level of concentration of ozone is less than 0.1 ppm and is within internationally accepted limits.
- Any changes to the equipment without written consent of the manufacturer will nullify the warranty and certifications.
- The bar is intended for use in indoor factory environments only. It is not suitable for outdoor use.



3. Positioning of the Bar

The best location is at, or immediately before, the area where static is causing the problem. Remember that static can be regenerated if the material passes over rollers or through a process after neutralising. A Static Meter such as the Fraser 715 is useful to determine the best position.



Important: Except on a winding reel of material (see the examples on the following page), the material to be neutralised must be in free air, not touching another surface as it passes the bar. It is not possible to neutralise static electricity where the material is touching another surface or roller.

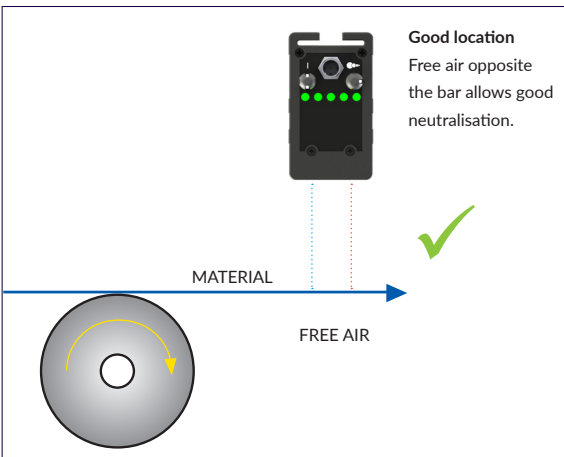
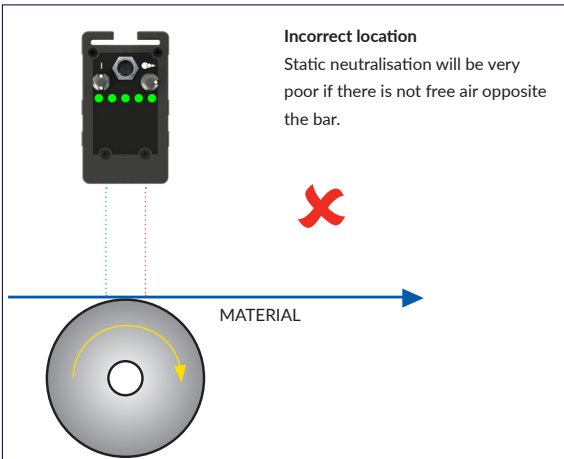

3. Positioning of the Bar

Generally, with a rewind or unwind, it is desirable to use a long-range bar to cope with the changing geometry so that you can neutralise the reel from the core to the finished diameter at the end of the wind.

There is an optimum location to neutralise the reel, which is shown by the following diagrams.

The principle is to neutralise the film AFTER it leaves the final roller and as it joins the reel.

Lay-on or Contact Roller Example

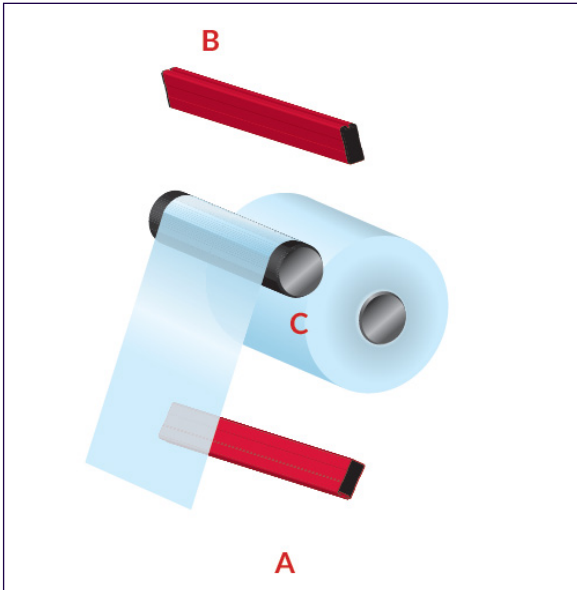

If there is a lay-on or contact roller (C), the best position for the X-SERIES is on the side where the film leaves the lay-on roller - in this case the underside (A) - because it can neutralise the charge as soon as it is created. If this is not practical, then position the bar on the top side. (B)

3. Positioning of the Bar

Centre Winder Example

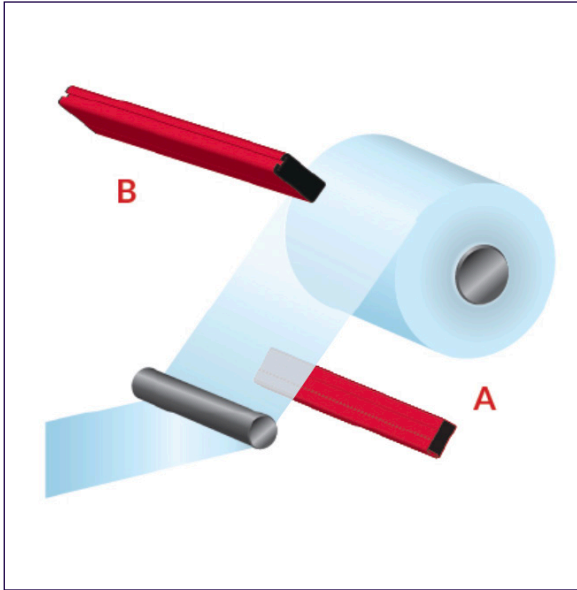

On a centre winder the X-SERIES bar may be positioned above or below the reel. It is a good idea for the ionisation to be directed mainly at the reel, but also catching the single sheet, as shown at (A). Position (B) is also acceptable.

It is often not possible to place a bar in the optimum position (A). The reason for this may be that the ideal bar location would get in the way of the loading/unloading process for the reels or would be in a position where operators might stand on it.

In a dirty or dusty environment, it is better to place the bar facing down, since the face of the bar will not be covered by the dust. This is not a problem. It is possible to position the bar at other positions, such as (B) and still achieve a very good result. We always say that a film web must be in 'free air' and not touching a roller to achieve good neutralisation. This is because we know that the charge on the material will temporarily combine with the roller and not be available for removal by the eliminator. This remains true. However, once you have a number of layers on a reel or winder, all with the same polarity of charge on them, the charge can no longer combine and can therefore be neutralised layer by layer.

4. Installation

Note: Long bars need careful handling during installation to avoid damage. Bars longer than 2,000 mm must be handled by two people.



- Use all of the 'T' fixings provided for mounting the bar. The 'T' fixings slide into the slot in the base of the bar. When mounting the bar, the 'T' fixings must be evenly distributed along the length of the bar. Do not allow more than 800 mm of unsupported bar between 'T' fixings.
- The bar must be dry and oil-free.
- Only mount the bar with the slot touching the machine or the mounting bracket.
- When mounting to the machine or on a bracket, make sure no metal extends beyond the slot in the bar. See the diagram below.

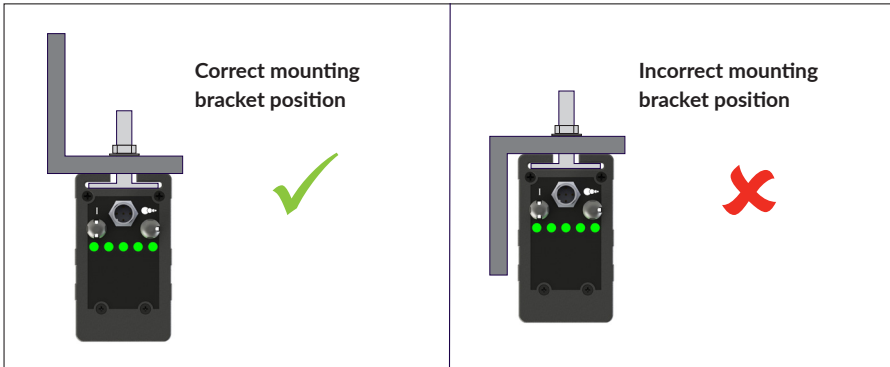

- It is important that the emitter pins are not touching, or close to metal objects, to avoid spark erosion that will damage both the bar and the metal object.



4. Installation

- The distance for the X-12F Eliminator from the material should be: 30 – 100 mm.
- The distance for the X-12L Eliminator from the material should be: 100 – 600 mm.
- The distance for the X-20 Eliminator from the material should be: 150 – 700 mm.
- The distance for the X-33 Eliminator from the material should be: 250 - 1500+ mm.

NB. ALL static eliminators are more effective at closer distance, subject to the specific minimum distance stated for each bar.

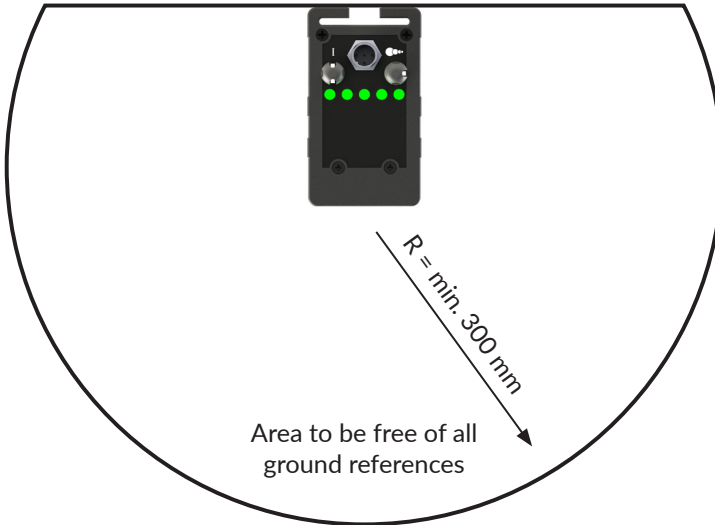

5. Electrical Connections

Warning!

The 0 V (negative) output of the 24 V DC supply to the bar must be earthed. If this is not done, the bar and the power supply will be damaged and all warranties will be voided.



Electrical connections to the bar are made via the M12 5-pole male connector on the endcap of the bar.

If using the Fraser Anti-Static external Power Supply Unit (Part No. NEOS-PSU), connect the M12 cable from the Power Supply Unit to the bar and ensure that the supplementary ground wire is connected to the installation protective earth before connecting mains power.



If using a separate 24 V Power Supply and Cable (e.g. as part of a machine control cabinet installation), follow the instructions in Section 5.2 for connecting the bar.



5. Electrical Connections

5.1 M12 Pin Assignments

The M12 connector pin numbering scheme is shown below.

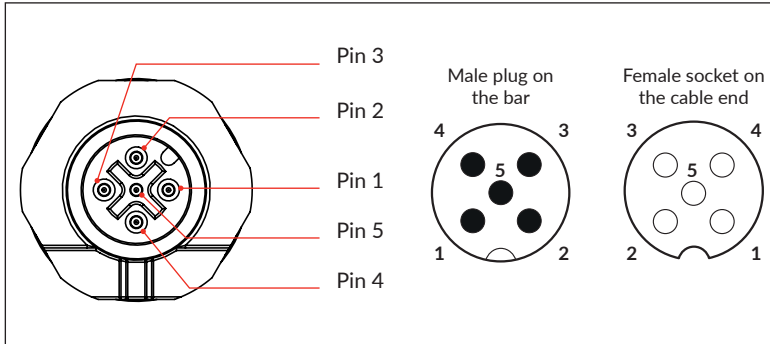

The pin assignment and typical wire colours are given in the table below. The table refers to cables supplied by Fraser. Other cables can have different colour schemes.

Pin	Colour	Function
1	Brown	24 V
2	White	Fault
3	Blue	0 V and Earth
4	Black	Clean Me
5	Grey or Green/Yellow	Disable

5. Electrical Connections

5.2 Power Supply Connections

The diagram below shows the power supply connection requirements.

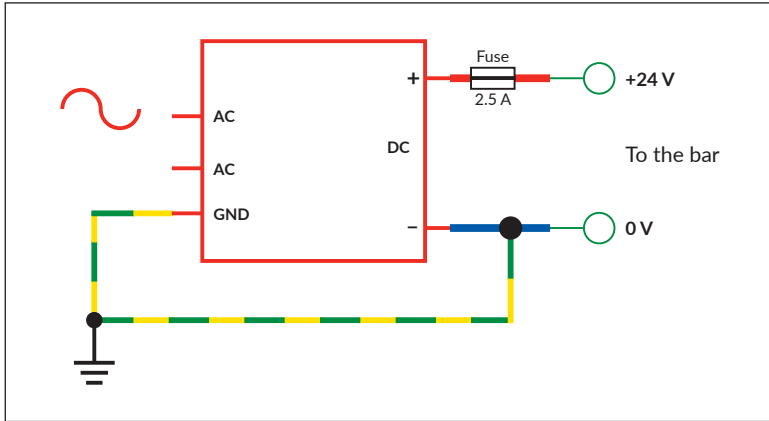

The 24 V supply connection (Pin 1, brown wire) must be fitted with a 2.5 A fuse. It is recommended that a type 'T' or 'gG' fuse is used.

The 0 V supply connection must be connected to the installation protective earth (PE). This connection should be made at the power supply output terminal if possible. There is no additional grounding connection to the bar - it is essential that this connection is made externally.

Warning!

If the 0 V output of the DC power supply is not grounded, there is a risk that the operator can receive an electric shock from the M12 connector on the bar.



Caution!

If the 0 V output of the DC power supply is not grounded, damage can occur to the power supply and/or the bar.



Caution!

If the 0 V output of the DC power supply is not grounded the residual voltage (balance) level of the bar cannot be guaranteed.



6. Status LEDs

6.1 Status Led and Remote Monitor

The X-SERIES range of bars provides a signal showing its operational status in the following ways:

i. Status LEDs

The status of the bar, including the need for cleaning, is indicated by the 3 or 5 bi-colour LEDs on the endcap.

X-12 (F & L Versions)



X-20



X-33





X-12 & X-20 LED INDICATION
DURING NORMAL OPERATION

LED Indication (X-12 & X-20 Only)	Bar Status	Ionisation
All off ○ ○ ○	The bar is not powered	Inactive
All flashing red ● ● ●	Standby mode	Inactive
All solid red ● ● ●	There is a fault with the bar	Inactive
Alternate flashing red ● ○ ● then ○ ● ●	Entering Config Mode (Flash sides then middle)	Inactive
Alternate flashing red ○ ● ○ then ● ○ ●	Exiting Config Mode (Flash middle then sides)	Inactive
Single Solid Green LED ● ○ ○	Manual Control - Short Distance Mode Selected	Active
Two Solid Green LED's ● ● ○	Manual Control - Mid-Range Distance Mode Selected	Active
Three Solid Green LED's ● ● ●	Manual Control - Long Distance Mode Selected	Active
All flashing green/red ● ● ●	'Clean Me'. The bar needs attention.	Active
Scrolling right, green ● ● ●	Positive Intelligence. The speed is proportional to the level of intelligence.	Active
Scrolling left, green ● ● ●	Negative Intelligence. The speed is proportional to the level of intelligence.	Active



6. Status LEDs

WHEN IN CONFIG MODE

Pressing  Button

LED Indication (X-12 & X-20 Only)	Bar Status	Ionisation
Single Green LED 	Short Distance Mode Selected	Inactive
Two Green LED's 	Mid-Range Distance Mode Selected	Inactive
Three Green LED's 	Long Distance Mode Selected	Inactive







Pressing  Button

LED Indication (X-12 & X-20 Only)	Bar Status	Ionisation
Green Middle LED 	Intelligence Control ON Selected	Inactive
Red Middle LED 	Intelligence Control OFF selected	Inactive

6. Status LEDs

X-33 LED INDICATION

DURING NORMAL OPERATION

LED Indication (X-33 Only)	Bar Status	Ionisation
All off 	The bar is not powered	Inactive
All flashing red 	Standby mode	Inactive
All solid red 	There is a fault with the bar	Inactive
All flashing green/red 	'Clean Me'. The bar needs attention.	Active
All flashing green 	Frequency of the HV. Bar OK.	Active
Scrolling right, green 	+ Intelligence. The speed is proportional to the level of intelligence.	Active
Scrolling left, green 	- Intelligence. The speed is proportional to the level of intelligence.	Active

ii. Remote Monitor

The bar is equipped with a remote monitoring interface that allows the operating status of the bar to be fed into a PLC system or checked remotely.

The voltage is taken from the power supply to the bar. No additional power source is required.

The voltage out will be the same as the voltage in: 21 - 28 V DC.

See Section 10 for wiring examples for the remote monitoring interface.



7. Operation, Maintenance and Safety

This section describes the adjustments available on the bar, commissioning the bar for use, maintenance procedures and a safety overview.

The operation of the integrated remote monitoring function is described in Section 7, Electrical Installation and Monitoring.

7.1 The Distance Control



Distance Setting

Use the Distance Control switch shown above to adjust the setting for the required distance to the target.

The Distance Control alters the frequency of the duty cycle:

- High frequency is best for short range
- Low frequency is best for long range

X-12 & X-20 DISTANCE SETTINGS

Enter config mode by pressing the distance setting button () for 3 seconds.



Once the LED's flash red, each subsequent press of the Distance setting button will cycle through the modes shown below.

X-12F DISTANCE MODE RECOMMENDATIONS



Control Position		Neutralisation Distance	X-12F Frequency
1	● ○ ○	40 mm - 100 mm	35 Hz
2	● ● ○	80 mm - 150 mm	20 Hz
3	● ● ●	125 mm - 250 mm	1 Hz

7. Operation, Maintenance and Safety

X-12L Distance Mode Recommendations

Control Position		Neutralisation Distance	X-12L Frequency
1		100 mm - 300 mm	5 Hz
2		150 mm - 400 mm	2 Hz
3		350 mm - 600 mm	1 Hz

X-20 DISTANCE MODE RECOMMENDATIONS

Control Position	Neutralisation Distance	X-20 Frequency
1 	150mm - 400 mm	5 Hz
2 	300 mm - 500 mm	2 Hz
3 	450 mm - 700 mm	1 Hz





If no buttons are pressed for 3 seconds, the bar will return to normal mode automatically.

Note:

High Voltage Operation is DISABLED for X-12 and X-20 whilst setting changes are being made.



X-33 DISTANCE MODE RECOMMENDATIONS

Control Position	Neutralisation Distance	X-33 Frequency
1 	250 mm - 500 mm	5 Hz
2 	350 mm - 750 mm	2.5 Hz
3 	500 mm - 1,000 mm	1 Hz
4 	750 mm - 1,500 mm	0.5 Hz

Warning!

For X-33 Bars - Turn off the bar when changing the setting.



7. Operation, Maintenance and Safety

7.2 The Intelligence Control



Intelligence Setting **INT**

Use the Intelligence Control button or switch to select Manual or Intelligent operation.

In Manual mode, the bar produces ionisation purely determined by the setting of the Distance Control rotary switch.

In Intelligent mode, the bar continuously assesses the state of the charge on the web and modifies the operating parameters of the bar to give optimal ionisation under all conditions. It adjusts the polarity, duty cycle and frequency of the ion emission to suit the application.

The Intelligence setting can **double the neutralisation power** of a X-SERIES ion bar in Manual mode. X-SERIES Intelligence monitors the charge in the target and adjusts the ion emission to achieve faster neutralisation. There are practical limits to the sensing capability of the X-SERIES Eliminator Bar - if the electric field is weak or at a long distance it will be more difficult to monitor.

X-12 & X-20 INTELLIGENCE SETTINGS

Enter config mode by pressing the intelligence setting button (**INT**) for 3 seconds. Once the LED's flash red, each subsequent press of the Intelligence setting button will cycle through the modes shown below.

Control Position	Intelligence	Function
1	○ ● ○	OFF The bar operates in Manual mode.
2	○ ● ○	ON The bar operates in Intelligent mode.

If no buttons are pressed for 3 seconds, the bar will return to normal mode automatically.

Note:

High Voltage Operation is DISABLED for X-12 and X-20 whilst setting changes are being made.



X-33 INTELLIGENCE SETTINGS

Control Position	Intelligence	Function
0	●	OFF The bar operates in Manual mode.
1	○	ON The bar operates in Intelligent mode.

Warning!

For X-33 Bars - Turn off the bar when changing the setting.



7. Operation, Maintenance and Safety

7.3 Selecting the Best Setting

The factory settings for the X-SERIES are Intelligence ON and Distance Control position 2. This gives intelligent operation at medium distances.

This setting can be changed to meet the actual requirements of the installation. Typical reasons for this could be:

1. Distance

The X-SERIES intelligence loses sensitivity with distance, especially if the static charge level is not high. The Distance settings correspond to the distance to the object to be neutralised. See the distance chart for guidance.

2. Installation

If there are metal parts in the target area or close to the X-SERIES bar, these could interfere with the sensing - giving it misleading information. See Positioning in Section 3.

3. Intermittent Static Charge

For example, if the target is not continuously present there is no charge to sense. In this case it can be better to turn off Intelligence and just use a Distance setting.

4. Speed of Process

Faster material speeds benefit from closer distances and higher frequencies.

A small amount of experimentation can be needed to produce the best performance for the application. Use the rotary switch controls on the endcap to change the settings.

Warning!

For X-33 Bars - Turn off the bar when changing the setting.

See the chart below for the typical range of each Distance setting.



X-12F DISTANCE MODE RECOMMENDATIONS

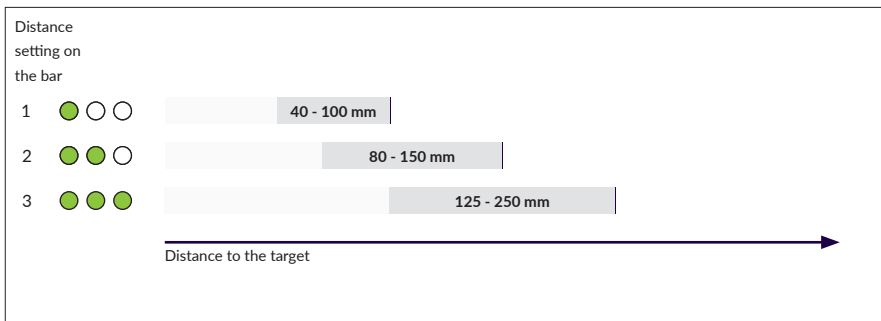

7. Operation, Maintenance and Safety

X-12L DISTANCE RECOMMENDATIONS

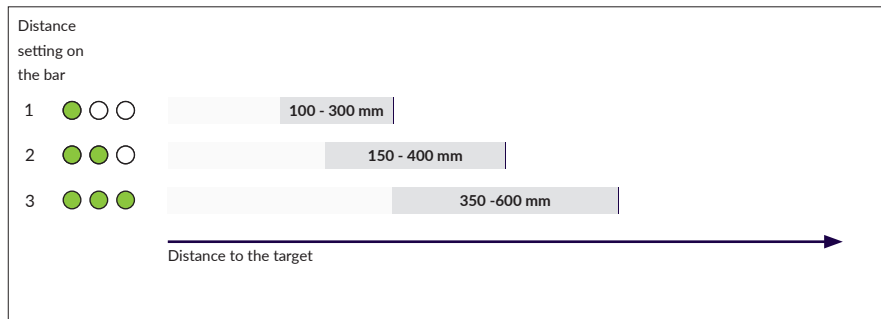

X-20 DISTANCE RECOMMENDATIONS

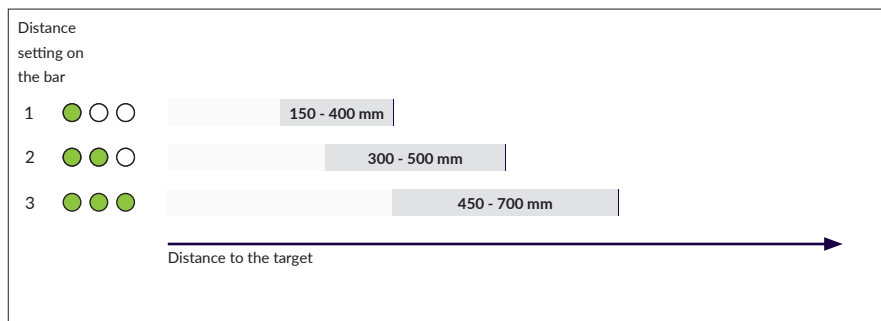

X-33 DISTANCE RECOMMENDATIONS

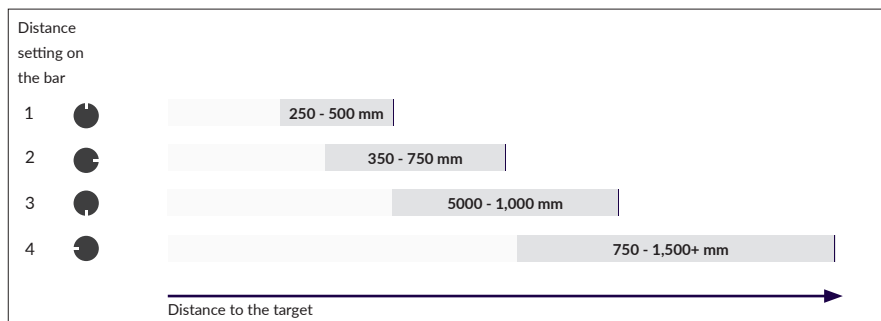

8. Commissioning

Before turning on the bar for the first time, check:

- The positioning and mounting of the bar is in accordance with the instructions given in Section 3 and Section 4 of this document.
- The electrical installation of the bar has been completed in accordance with the instructions given in Section 5 of this document. In particular, ensure that the 0 V output of the 24 V supply is connected to the installation protective earth.
- If using the external AC-DC power supply, make sure that the supplementary grounding wire is connected to the installation protective earth.
- Make sure the Distance and Intelligence controls are correctly set. See Section 7.
- Any operators who will work in close proximity to the bar are aware of its presence and familiar with its operation.



9. Maintenance

Warning!







Always disconnect the power before working on the bar.

- Cleaning is the only maintenance required. Dirt around the emitters will reduce ionisation effectiveness and result in unsatisfactory static neutralisation performance.
- The frequency of cleaning will depend on the process and the environment in which the bar is installed. The bar should be cleaned when 'Clean Me' is indicated by the endcap LEDs and/or the remote monitoring interface.
- Our Fraser cleaning kit (Part No. 81220) is ideal for use, alternatively a toothbrush or nail brush can be used. Do not use a wire brush as this could damage the bar.
- The bar can be washed with soapy water or Isopropyl alcohol (IPA), but it must be dry around the emitters before turning the power on.
- Please note, when handling and cleaning, that the emitter pins are sharp and care is needed!
- The emitter pins are shockless - there is a large resistor below each emitter reducing the current to a shockless level. However please note that DC current can transfer charge to a body if it is touching or close to an emitter for a longer period. This could give a shock when discharging.
- The emitters on the X-20 and X-33 Range should be replaced every two years or when worn. Please use the emitter key supplied with the bar to remove/replace.



10. Troubleshooting

In the event of problems with the bar, please use the following checks.

Symptom	Cause(s)	Solution(s)
Green LEDs: solid, flashing or scrolling	The bar is operating correctly	<ul style="list-style-type: none"> See Section 6.1 for further information
No lit LEDs ○○○○○	Bar not powered	<ul style="list-style-type: none"> Check the power supply and connections Check the fuse Check the supply cable for damage
Flashing red LEDs  = X-12 & X-20  = X-33	Standby mode. The DISABLE signal is active (18 - 28 V)	<ul style="list-style-type: none"> Reduce the voltage at the DISABLE input to less than 12 V to restore the normal operation of the bar
Solid red LEDs  = X-12 & X-20  = X-33	Power supply voltage outside of specified range	<ul style="list-style-type: none"> Check and adjust the power supply voltage Make sure that a correct power supply cable is used Ensure the power supply is not overloaded
	HV supplies overloaded	<ul style="list-style-type: none"> Check the installation of the bar Move the bar further from earthed metal objects Check the bar for damage
	Internal fault	<ul style="list-style-type: none"> Contact your supplier
Alternate flashing red/green LEDs  = X-12 & X-20  = X-33	Emitters need cleaning	<ul style="list-style-type: none"> Turn off the power to the bar then clean the bar
	Bar is installed too close to machine parts	<ul style="list-style-type: none"> Check the installation of the bar Move the bar further from metal parts
Poor Ionisation/ Neutralisation Performance	Emitters need cleaning	<ul style="list-style-type: none"> Turn off the power to the bar then clean the bar
	Emitters worn	<ul style="list-style-type: none"> Check emitters for excessive wear Replace the emitters (X-20 & X-33 only)
	Bar is installed too close to machine parts	<ul style="list-style-type: none"> Review the installation If possible, move the bar away from machine parts
	Bar is installed too far from the material to be neutralised	<ul style="list-style-type: none"> Review the installation If possible, move the bar closer to the material to be neutralised
	Bar is installed opposite roller/machine parts	<ul style="list-style-type: none"> Review the installation If possible, move the bar opposite material in free air

11. Remote Interface and Wiring Examples

This section describes the functioning of the remote monitoring interface in more detail and provides wiring examples for common installation types.

11.1 Signalling

The X-SERIES Range of Ionising bars features two PLC Type 1, 2 and 3 compatible outputs to enable remote monitoring of the bar status, and a DISABLE input to allow the HV supplies to be externally disabled when not required ('Standby' mode). For example, the bar can be linked into the safety interlock system of the machine to ensure operator safety during changeover periods.

See wiring diagram and examples below.

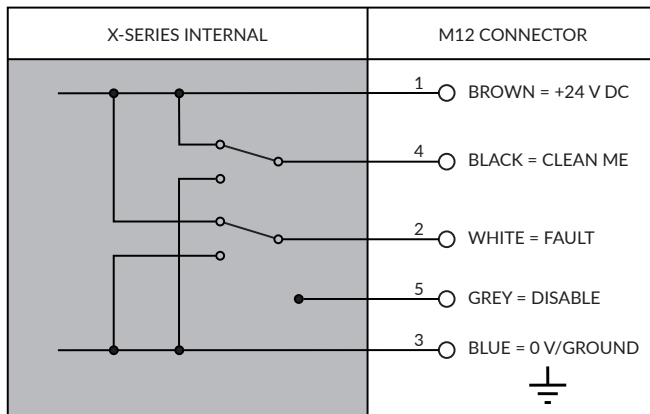
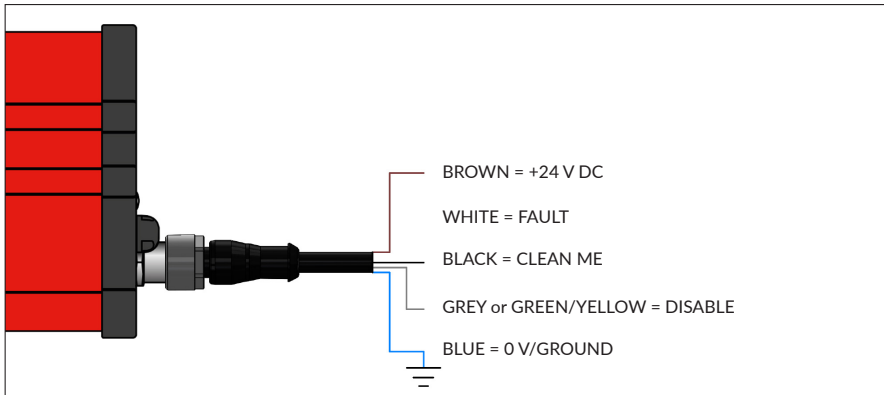

11. Remote Interface and Wiring Examples

Remote Monitor outputs (Fault, Clean Me)

Both outputs are compatible with IEC 61131-2 Type 1, Type 2 and Type 3 PLC inputs, capable of sinking or sourcing 50 mA continuously. The outputs can also be used for direct driving of external lamps or relays. See wiring diagram and examples in the next section.

The remote monitor signals are valid 5 seconds after power is applied, according to the following conditions:

Condition	Ionisation	Fault (White, Pin 2)	Clean Me (Black, Pin 4)
Bar powered, all OK	Active (HV ON)	HIGH	HIGH
Bar powered, requires attention (e.g. cleaning)	Active (HV ON)	HIGH	LOW
Overload, hardware fault or standby mode.	INActive (HV OFF)	LOW	LOW
Standby mode	INActive (HV OFF)	LOW	HIGH

LOW <0.5 V, HIGH >20 V, when VIN = 24 V at 25 °C
Maximum current sink/source = 50 mA.
Internally protected by electronic fuses.

A working bar in good operating condition will thus internally connect both outputs to >20 V. Signalling becomes valid 5 seconds after power is applied.

Caution!

Voltage applied to the outputs must not exceed 28 V DC and must be of the correct polarity.



11. Remote Interface and Wiring Examples

11.2 Example Applications

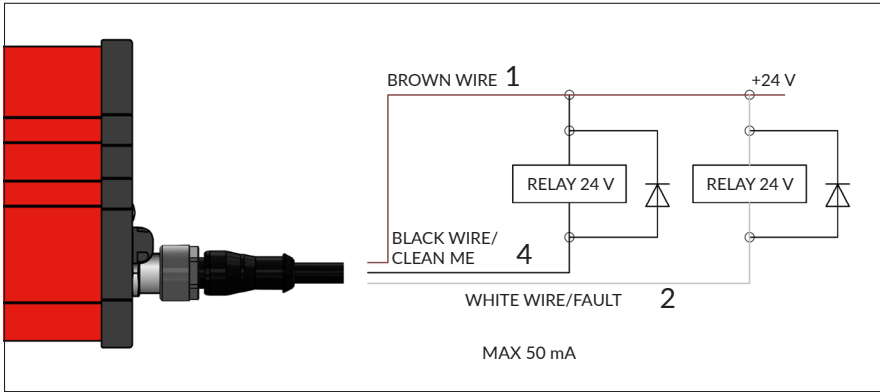

External PLC Input Type 1, Type 2 or Type 3

Interfacing to an external 24V IEC 61131-2 Type 1, Type 2 or Type 3 PLC digital input can be achieved by direct connection.

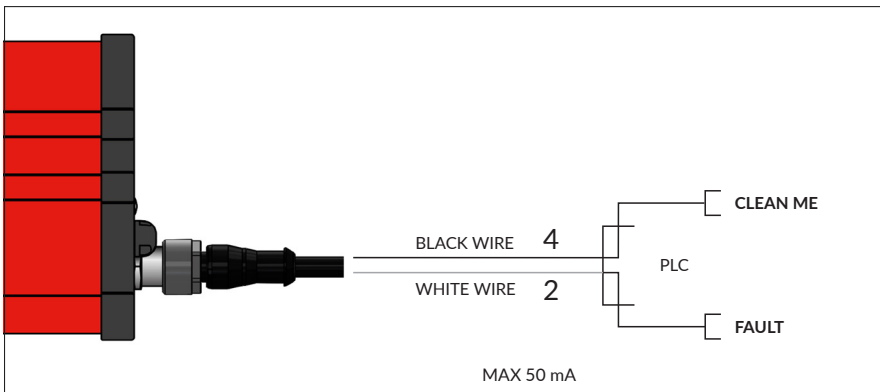

11. Remote Interface and Wiring Examples

11.3 Remote DISABLE input

The X-SERIES Range of Ionising bars features a remote DISABLE input signal (Grey or Green/ Yellow wire). This may be useful for installations in which the bar is not used continuously and it is desirable that the bar should be inactive when not required, or in installations in which the operation of the bar is to be interlocked with other machinery.

The HV supplies may be externally disabled (Standby mode) by applying any DC voltage between 18 V and 28 V to the DISABLE input, for example by using an external switch or relay contact between the DISABLE input and 24 V. Subsequently reducing the voltage at the DISABLE input to less than 12 V restores normal operation of the bar.

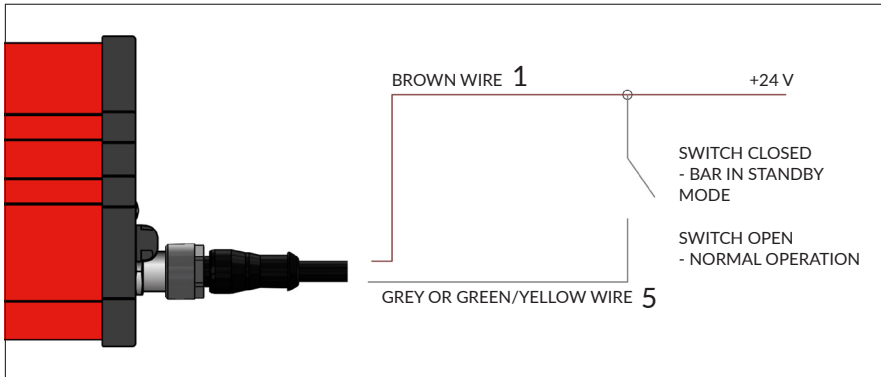

In Standby mode the internal HV supplies of the bar are disabled, the status LEDs flash red, and the OK output is inactive (open circuit) to indicate that ionisation is disabled. The DISABLE signal has a weak internal pull-down resistor, thus if the DISABLE signal is left disconnected the bar will operate normally.

Caution!

Voltage applied to the DISABLE input must not exceed 28 V DC, and must be of the correct positive polarity. The bar may be permanently damaged by connecting the DISABLE input to any voltage outside the range of 0 V - 28 V DC.



Warning!

Where the optional NEOS-PSU has been ordered ensure the Power Unit is connected to a 3-wire AC mains supply, Live + Neutral + Ground, and that the extra Earth wire from the power supply is bonded to Ground. With this optional supply an interface cable is required to access the remote monitor feature.



12. Specification and Dimensions

Power Supply	X-12	X-20	X-33
Input voltage	24 V DC nominal, 21 - 28 V operating range. 0 V earthed.	24 V DC nominal, 21 - 28 V operating range. 0 V earthed.	24 V DC nominal, 21 - 28 V operating range. 0 V earthed.
Input current	2.5 A max.	2.5 A max.	2.5 A max.
Maximum input power	20 W	40 W	60 W
Input connector	M12, 5-pole, male	M12, 5-pole, male	M12, 5-pole, male

Output	X-12	X-20	X-33
Output voltage	±12 kV (-0/+10%)	±20 kV (-0/+10%)	±33 kV (-0/+10%)
Emitter material	Long-life, high-grade tungsten (non-replaceable)	Replaceable Long-life, high-grade tungsten	Replaceable Long-life, high-grade tungsten
Emitter touch current	100 µA max. per emitter	100 µA max. per emitter	100 µA max. per emitter

Monitoring (All X-SERIES Models)

Endcap LED status indication	Green flashing, Solid or scrolling: OK, bar is operating normally Red/Green flashing: 'Clean Me' - attention required Flashing Red: standby mode Solid Red: supply voltage out of range or internal fault
------------------------------	--

Remote Monitor (All X-SERIES Models)

Signalling outputs	'Fault' and 'Clean Me'
Signalling levels	0 V / 24 V output
Output current	Sourcing (+24 V): 50 mA Sinking (0 V): 50 mA Limited to 50 mA max.

PLC (All X-SERIES Models)

Compatibility	Compatible with IEC 61131-2 Type 1, 2 and 3 PLC inputs
Remote monitor states	Bar OK, 'Clean Me', Fault, Bar not powered

Protection (All X-SERIES Models)

Internal protection	Under-voltage/over-voltage lockout, surge protection, reverse supply polarity protection. Over-temperature protection. HV supplies protected against overload. Signalling outputs protected against short-circuiting.
---------------------	--

12. Specification and Dimensions

Environmental Conditions	X-12	X-20	X-33
Ambient temperature	0 - 55 °C	0 - 55 °C	0 - 55 °C
Relative humidity	Maximum 70 %, non-condensing	Maximum 70 %, non-condensing	Maximum 70 %, non-condensing
Ingress protection	IP67. Internal, industrial use.	IP67. Internal, industrial use.	IP64. Bar will not be damaged by exposure to water, but will not function correctly if the emitters are bridged by moisture.

Mechanical	X-12	X-20	X-33
Dimensions	25 x 45 mm (W x H)	28 x 66.5mm (W x H)	52.8 x 93 mm (W x H)
Length	X-12F - Minimum length 360 mm to 4.98 m in 60 mm steps X-12L - Minimum length 360 mm to 4.92 m in 120 mm steps	Minimum length 450 mm to 4.95m in 150 mm steps	Minimum length 600 mm then 750 mm to 6,000 mm in 250 mm steps
Mass	1.5kg/m	2.5kg/m	1.02 kg + (2.5 kg/m) e.g. 1,000 mm bar: 3.52 kg
Materials	FR-ABS, epoxy resin, tungsten emitters, steel fixings.	FR-ABS, epoxy resin, tungsten emitters, steel fixings.	FR-ABS, epoxy resin, tungsten emitters, steel fixings.

Approvals	
CE Marking	CE. CB
EU LVD (2014/35/EU)	EN 62368-1:2014
EU EMCD (2014/30/EU)	Emissions: EN 61000-6-3:2007 Immunity: EN 61000-6-2:2005

12. Specification and Dimensions

X-12 Specifications

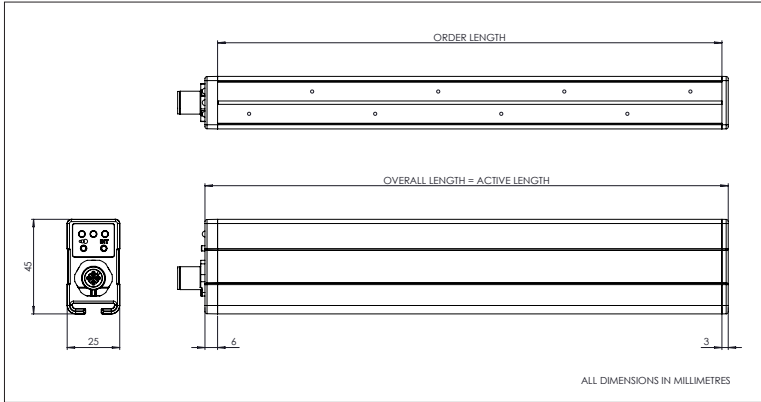

X-20

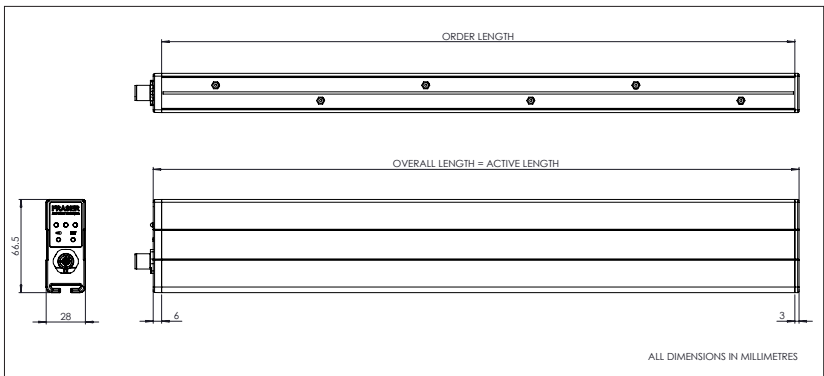

X-33

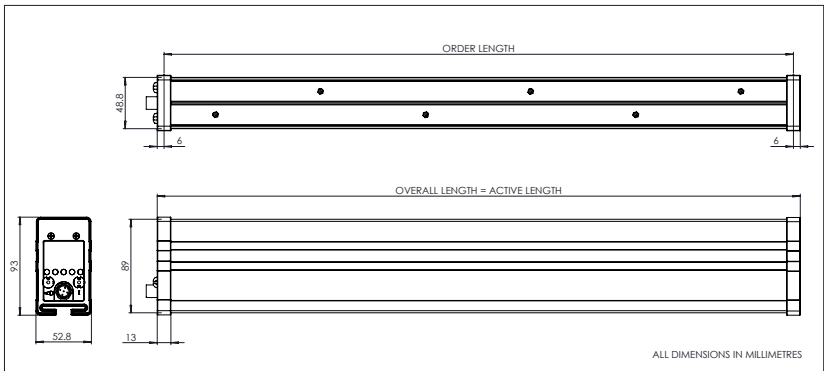

13. Spare Parts and Accessories

A range of accessories to assist with installation and maintenance of the Bar is available from Fraser Anti-Static Techniques. Please contact your Technical Sales Liaison with any pricing and delivery queries on these items.

Item Picture	Description	Part No.
	3 m cable. M12 female, bare ends. Straight socket.	81193
	5 m cable. M12 female, bare ends. Straight socket.	81194
	7.5 m cable. M12 female, bare ends. Straight socket.	81195
	10 m cable. M12 female, bare ends. Straight socket.	81196
	3 m cable. M12 female, bare ends. 90° socket.	81199
	5 m cable. M12 female, bare ends. 90° socket.	81200
	7.5 m cable. M12 female, bare ends. 90° socket.	81201
	10 m cable. M12 female, bare ends. 90° socket.	81202

13. Spare Parts and Accessories

Item Picture	Description	Part No.
	Universal AC-DC power supply: 100 - 250 V AC, 24 V DC output. Fitted with 1.5 m of cable.	NEOS- PSU
	X-12 & X-20 Mounting 'T' Bracket and flanged nut.	X-12 - 341210 X-20 - 34208
	X-33 'T' fixing (40 mm) including flanged nut	36321
	Replacement Emitter (X-20 & X-33 Units Only)	34201
	Replacement Emitter Key (X-20 & X-33 Units Only)	342018
	Fraser Ioniser Cleaning Kit: - 1000 ml of cleaning fluid - Soft bristle hand brush - Instructions for use	81220

For more information about static and to view the full range
of our products, please visit www.fraser-antistatic.com



Fraser Anti-Static Techniques Ltd | Scotts Business Park, Bampton, Devon, EX16 9DN, UK
T +44 (0) 1398 331 114 E sales@fraser-antistatic.co.uk W www.fraser-antistatic.com

© Fraser Anti-Static Techniques Ltd 2024 | X-Series 01 - Iss.1 - EN

